

- One to eight MP-Series, RDD-Series, or LDC-Series rotary/linear motors or linear actuators (support for Heidenhain EnDat high-resolution feedback on RDD-Series motors has not been implemented)
- One to eight motor power and feedback cables
- Two to nine SERCOS fiber-optic cables
- Ethernet cables for Logix control and programming the safety configuration

Kinetix 6200 and Kinetix 6500 systems may also include any of these optional components:

- One or more IAM power modules used as a follower IAM, 2094-BCxx-Mxx-M (460V) and associated axis modules, power rails, motors, and cables as required for the application.
- One shunt module, 2094-BSP2 with optional Bulletin 1394 external passive shunt module
- Slot-filler modules, 2094-PRF
- Bulletin 2094 Line Interface Module (LIM)
- Bulletin 2090 Resistive Brake Module (RBM)

## Kinetix 6000 Drive Component Compatibility

The 2094-BCxx-Mxx-M and 2094-BMxx-M power modules contain the same power structure as the 2094-BCxx-Mxx-S and 2094-BMxx-S drive modules. Because of this, the 2094-BSP2 shunt module, 2094-PRF slot-filler module, and 2094-PRsx power rails are supported by both drive families.

In addition, 2094-BMxx-M AM power modules with SERCOS interface are supported on power rails with a 2094-BCxx-Mxx-S IAM drive module. Conversely, 2094-BMxx-S AM drive modules are supported on power rails with a 2094-BCxx-Mxx-M IAM power module with SERCOS interface.

**IMPORTANT** Kinetix 6500 EtherNet/IP control modules (catalog numbers 2094-EN02D-M01-Sx) are not compatible with IAM/AM modules on the same Bulletin 2094 power rail where SERCOS interface is used.

### IAM/AM Module Compatibility

IAM Module	Control Module	2094-xMxx-S Kinetix 6000 AM Module	2094-BMxx-M AM Power Modules	
			2094-SE02F-M00-Sx Kinetix 6200 Control Module	2094-EN02D-M01-Sx Kinetix 6500 Control Module
2094-xCxx-Mxx-S	N/A			
2094-BCxx-Mxx-M (IAM power module)	2094-SE02F-M00-Sx SERCOS interface	Fully compatible	Fully compatible	Not compatible
	2094-EN02D-M01-Sx EtherNet/IP network	Not compatible	Not compatible	Fully compatible

For more information on the Kinetix 6000 IAM and AM modules, catalog numbers 2094-xCxx-Mxx-S and 2094-xMxx-S, refer to Kinetix 6000 Multi-axis Servo Drives in [Chapter 6](#).

For more information on the Bulletin 2094 power rails, shunt module, slot-filler module, RBM and LIM modules, refer to Motion Control Accessories in [Chapter 12](#).

## Power Dissipation Specifications

Use this table to size an enclosure and calculate required ventilation for your Kinetix 6200 and Kinetix 6500 drive system.

Kinetix 6200 and Kinetix 6500 <sup>(1)</sup> Drive Modules	Usage as % of Rated Power Output (watts)				
	20%	40%	60%	80%	100%
IAM (converter) module <sup>(2)</sup>					
2094-BC01-MP5-M	18	21	25	29	34
2094-BC01-M01-M					
2094-BC02-M02-M	36	44	54	64	75
IAM (inverter) module or AM module <sup>(2)</sup>					
2094-BC01-MP5-M or 2094-BMP5-M	46	54	61	69	77
2094-BC01-M01-M or 2094-BM01-M	57	73	90	108	126
2094-BC02-M02-M or 2094-BM02-M	53	72	93	116	142
Shunt module					
2094-BSP2	68	121	174	227	280

(1) Power dissipation for the Bulletin 2094 control modules, catalog numbers 2094-SE02F-M00-Sx and 2094-EN02D-M01-Sx, is included in the IAM and AM power module specifications.

(2) Internal shunt power is not included in the calculations and must be added based on utilization.

Power dissipation specifications are based on these calculations. For example:

2094-BC02-M02-M with 4.52 A<sub>dc</sub> (=20%) converter DC current and 10.3 A<sub>rms</sub> (=100%) inverter output current.

Converter loss (36 W) + Inverter loss (142 W) = 178 W total power dissipation.

Kinetix 6000 systems may also include any of these optional components:

- One or more integrated axis modules used as follower IAM, 2094-ACxx-Mxx-S (230V) or 2094-BCxx-Mxx-S (460V) and associated axis modules, power rails, motors, and cables as required for the application
- One shunt module, 2094-BSP2 with optional Bulletin 1394 external passive shunt module
- Slot-filler modules, 2094-PRF
- Bulletin 2094 Line Interface Module (LIM)
- Bulletin 2090 Resistive Brake Module (RBM)
- Bulletin 1336 external active shunt module (dynamic brake)

## Kinetix 6000 IAM/AM Module Series Change

The peak current ratings of the Kinetix 6000 AM modules (series A and B) are configured at the factory as 150% of continuous current. You can program 460V (series B) AM modules and the equivalent IAM (inverter) modules, for up to 250% of continuous inverter current.

### Kinetix 6000 Series Change

IAM Module <sup>(1)</sup> Cat. No.	AM Module <sup>(1)</sup> Cat. No.	Peak Current Rating	
		Series A (inverter)	Series B (inverter)
2094-BC01-MP5-S	2094-BMP5-S	150%	250%
2094-BC01-M01-S	2094-BM01-S	150%	250%
2094-BC02-M02-S	2094-BM02-S	150%	250%

(1) Contact your Rockwell Automation sales representative for availability of 2094-BC04-M03-S, 2094-BM03-S, 2094-BC07-M05-S, and 2094-BM05-S series-B drive modules.

### IMPORTANT

Before your drive will deliver 250% peak performance, you must enable the peak enhancement feature by configuring your drive by using DriveExplorer or RSLogix 5000 software.

Refer to the interactive Peak Enhancement Configuration Utility to recalculate torque and accel/decel limit values, and paste them into the appropriate Axis Properties dialog box in RSLogix 5000 software. To download the utility, go to <http://ab.com/motion/software/peak.html>.

For sizing your drive/motor combination by using series-B drives and the peak enhancement feature, use Motion Analyzer software, version 4.6 or later.

## Weight Specifications

Kinetix 6000 Module	Cat. No.	Weight, approx. kg (lb)
IAM (230V)	2094-AC05-MP5-S	2.23 (4.9)
	2094-AC05-M01-S	2.27 (5.0)
	2094-AC09-M02-S	2.31 (5.1)
	2094-AC16-M03-S	4.71 (10.4)
	2094-AC32-M05-S	7.43 (16.4)
AM (230V)	2094-AMP5-S	1.46 (3.2)
	2094-AM01-S	1.50 (3.3)
	2094-AM02-S	1.54 (3.4)
	2094-AM03-S	3.13 (6.9)
	2094-AM05-S	3.18 (7.0)
Power rails (Slim)	2094-PRS1	1.05 (2.3)
	2094-PRS2	1.59 (3.5)
	2094-PRS3	2.14 (4.7)
	2094-PRS4	2.67 (5.9)
	2094-PRS5	3.11 (6.8)
	2094-PRS6	3.55 (7.8)
	2094-PRS7	3.99 (8.8)
	2094-PRS8	4.43 (9.7)

Kinetix 6000 Module	Cat. No.	Weight, approx. kg (lb)
IAM (460V)	2094-BC01-MP5-S	4.98 (11.0)
	2094-BC01-M01-S	5.03 (11.1)
	2094-BC02-M02-S	5.08 (11.2)
	2094-BC04-M03-S	9.60 (21.1)
	2094-BC07-M05-S	10.1 (22.3)
AM (460V)	2094-BMP5-S	2.44 (5.4)
	2094-BM01-S	2.49 (5.5)
	2094-BM02-S	2.54 (5.6)
	2094-BM03-S	4.58 (10.1)
	2094-BM05-S	4.98 (11.0)
Shunt module	2094-BSP2	3.10 (6.8)
Slot-filler module	2094-PRF	0.45 (1.0)

## Maximum Feedback Cable Lengths

Although motor feedback cables are available in standard lengths up to 90 m (295.3 ft), the drive/motor/feedback combination may limit the maximum feedback cable length. These tables assume the use of recommended cables as shown in the Motor/Actuator Cable Selection table on [page 380](#).

### Cable Lengths for Compatible Rotary Motors

Motor Cat. No.	Absolute High-resolution (5V) Encoder m (ft)	Absolute High-resolution (9V) Encoder m (ft)	Incremental/TTL (5V) Encoder m (ft)	Resolver m (ft)
MPL-A15xxx... MPL-A2xxx-E/V	30 (98.4)			
MPL-A3xxx... MPL-A5xxx-S/M <sup>(1)</sup>	30 (98.4)			
MPL-B15xxx... MPL-B2xxx-E/V		90 (295.3)		
MPL-B3xxx... MPL-B5xxx-S/M		90 (295.3)		
MPL-A/B15xxx... MPL-A/B45xxx-H			30 (98.4)	
MPL-Bxxx-R				90 (295.3)
MPM-Axxxxx-S/M	30 (98.4)			

## Power Rail Catalog Numbers

Catalog numbers consist of various characters, each of which identifies a specific option for that component. Use the catalog numbering table chart below to understand the configuration of your power rail. For questions regarding product availability, contact your Allen-Bradley distributor.

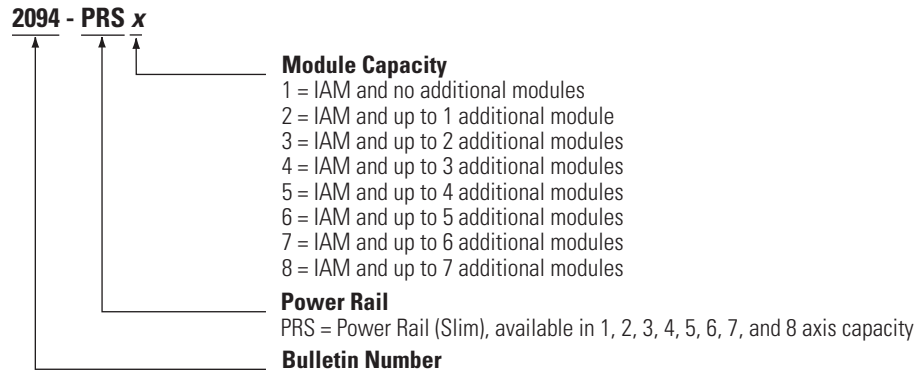

## Bulletin 2094 Shunt Module

The Bulletin 2094 shunt module is compatible with Kinetix 6000, Kinetix 6200, and Kinetix 6500 drive families. This section contains specifications, mounting dimensions, and catalog numbers for the 2094-BSP2 shunt module.

### IMPORTANT

The 2094-BSP2 shunt module is compatible with all 230V and 460V systems, however, the 2094-BSP2 shunt module is physically larger than the 230V drives and additional clearance is required beneath and in front of the module.

## Bulletin 2094 Shunt Module Power Specifications

The table below lists the power specifications for the Bulletin 2094 shunt module. Refer to [page 436](#) for tables with the Bulletin 2094 shunt module in combination with an IAM module internal shunt (when present) and the various external passive shunt resistors available for 230V and 460V drive systems. Use these tables to determine the combination you need based on the requirements of your application.

### Shunt Module Power Specifications

Shunt Module Cat. No.	Specifications						Short Circuit Current Rating A	Fuse Replacement
	Drive Voltage V AC	Resistance $\Omega$	Peak Power kW	Peak Current A	Continuous Power W	Capacitance $\mu\text{F}$		
2094-BSP2	230	28.75	5.7	14	200	470	200,000 symmetrical	N/A (no internal fuse)
	460		22.5	28				

For specifications and dimensions of external shunt resistors compatible with your Kinetix 6000 or Kinetix 6200 drive, refer to External Shunt Modules beginning on [page 471](#).

### Shunt Module Catalog Numbers

Catalog numbers consist of various characters, each of which identifies a specific option for that component. Use the catalog numbering table chart below to understand the configuration of your module. For questions regarding product availability, contact your Allen-Bradley distributor.

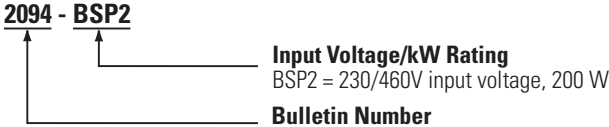

### Bulletin 2094 Slot-filler Module

The Bulletin 2094 slot-filler module is compatible with Kinetix 6000, Kinetix 6200, and Kinetix 6500 drive families. This section contains dimensions and catalog numbers for the 2094-PRF slot-filler module.

**IMPORTANT** The 2094-PRF slot-filler module is compatible with all 230V and 460V systems. Power rail slots not occupied by an IAM, AM, or shunt module, must have a slot-filler module installed.

### Slot-filler Module Dimensions

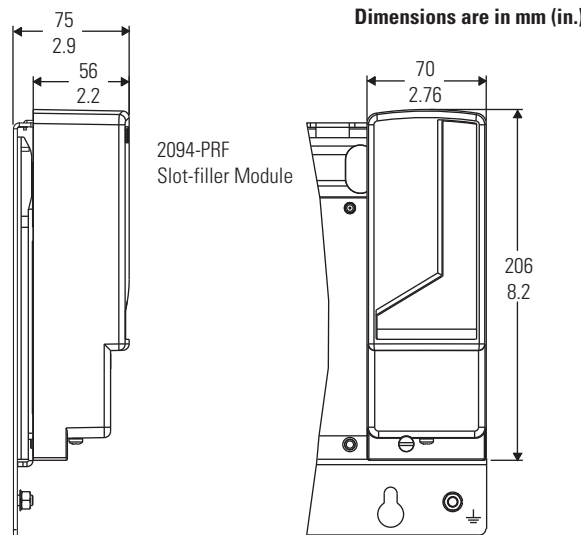

### Slot-filler Module Catalog Numbers

Catalog numbers consist of various characters, each of which identifies a specific option for that component. Use the catalog numbering table chart below to understand the configuration of your module. For questions regarding product availability, contact your Allen-Bradley distributor.

