

Product Overview

Providing users with powerful motor speed control in a compact, space saving design, the Allen-Bradley® PowerFlex® 4 and 40 AC drives are the smallest and most cost-effective members of the PowerFlex® family of drives. Available in power ratings from 0.2 to 11 kW (0.25 to 15 HP) and in voltage classes of 120, 240, 480 and 600 volts, PowerFlex 4 and 40 are designed to meet global OEM and end-user demands for flexibility, space savings, ease of use and are cost-effective alternatives for speed control of applications such as machine tools, fans, pumps and conveyors and material handling systems



Reference Materials

For additional PowerFlex 4 and 40 data and general drive information, refer to the following publications:

Title	Publication	Online
PowerFlex 4 User Manual	22A-UM001	www.rockwellautomation.com/literature
PowerFlex 40 User Manual	22B-UM001	
Wiring and Grounding Guidelines for PWM AC Drives	DRIVES-IN001	
Preventive Maintenance of Industrial Control and Drive System Equipment	DRIVES-TD001	
Safety Guidelines for the Application, Installation and Maintenance of Solid State Control	SGL-1.1	

For other information, contact Allen-Bradley Drives Technical Support:

Title	Online
Allen-Bradley Drives Technical Support	www.ab.com/support/abdrives

Shaded areas are applicable to PowerFlex 40 only.

Packaging and Mounting

- Installation can be a virtual snap using the **DIN rail mounting** feature on A and B frame drives. Panel mounting is also available, providing added flexibility.
- **Flange mount** drives are available to reduce overall enclosure size.
- **Zero Stacking™** is allowable for ambient temperatures up to 40 °C, saving valuable panel space. 50 °C ambient temperatures are permitted with minimal spacing between drives.
- **Integral filtering** is available on all 230V single phase ratings, providing a cost-effective means of meeting EN55011, Class A and B EMC requirements. External filters provide compliance to Class A and B requirements for all PowerFlex 4 and 40 ratings.
- An optional **IP30, NEMA/UL Type 1 conduit box** is easily adapted to the standard IP20 (NEMA Type Open) product, providing increased environmental ratings.
- **IP66, NEMA/UL Type 4X/12** (Indoor) for mounting directly in the product environment. Listed by UL to resist dust, dirt, etc. and survive high pressure water spray. Also certified by NSF to ensure conformity with international food equipment standards.



Start Up, Programming and Operation

- An **integral keypad** provides out of the box operation using the local potentiometer and control keys.
- The 10 most common application parameters are contained in the **Basic Program Group**, making programming fast and easy.
- The **programming keys** have the same function as all other PowerFlex drives, so if you can program one PowerFlex drive, you can program them all.
- **4 digit display** with 10 additional LED indicators provides an intuitive display of drive status and information.
- Integral **RS-485 communications** can be used for programming from a PC. It can also be used in a multi-drop network configuration. A serial converter module provides connectivity to any controller with a DF1 port.
- A **NEMA/UL Type 4X remote** and **NEMA/UL Type 1 hand-held LCD keypad** provide additional programming and control flexibility, both featuring the popular CopyCat function.



Optimized Performance

- **Removable MOV** to ground provides trouble-free operation when used on ungrounded distribution systems.
- A **relay pre-charge** limits inrush current.
- **Integral brake transistor**, available on all ratings (except no brake version), provides dynamic braking capability with simple low cost brake resistors.
- DIP switch settable **24V DC sink or source control** for control wiring flexibility.
- 150% overload for 60 seconds or 200% overload for 3 seconds provides **robust overload protection**.
- **Adjustable PWM frequency up to 16 kHz** ensures quiet operation.



Sensorless Vector Performance

PowerFlex 4

- Drive automatically provides auto boost (IR compensation) and slip compensation.
- Provides excellent speed regulation and high levels of torque across the entire speed range of the drive, and improved speed regulation even as loading increases.

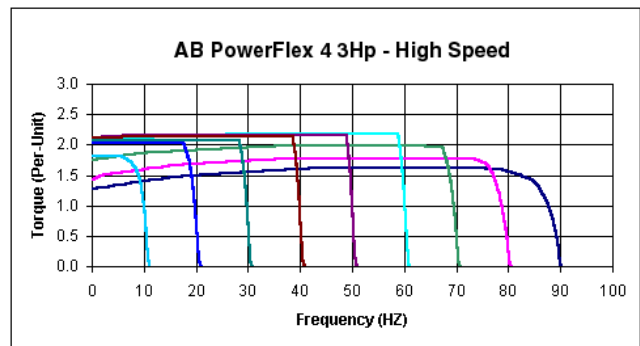

Sensorless Vector Control

PowerFlex 40

- Sensorless Vector Control provides exceptional speed regulation and very high levels of torque across the entire speed range of the drive.
- The Autotune feature allows the PowerFlex 40 to adapt to individual motor characteristics.

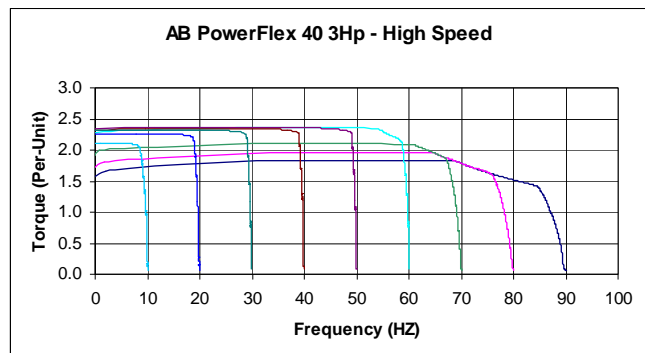

Performance

- This graph depicts the ability of a PowerFlex 40 drive to accelerate into at least 150% load. A PowerFlex 4 will perform similarly, but with a slightly higher acceleration time.
- At 100% motor load, the drive will run the motor at synchronous speed.
- Excellent current regulation.
- Linear acceleration.
- Best in class digital input response time and repeatability.

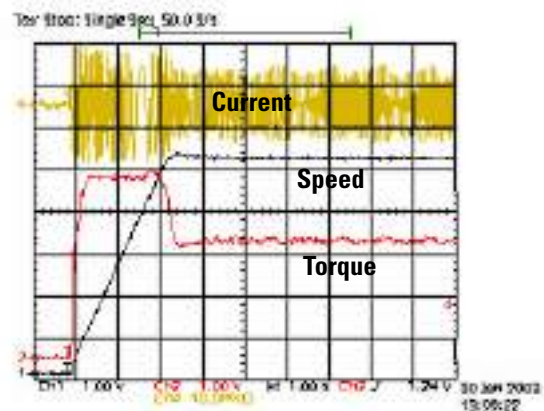

Performance

- **Sensorless Vector Control** develops high torque over a wide speed range and adapts to individual motor characteristics.
- **Variable PWM** allows the drive to output more current at low frequencies.
- Integral **PID** functionality enhances application flexibility.
- **Timer, Counter, Basic Logic and StepLogic™ functions** can reduce hardware design costs and simplify control schemes.
 - **Timer function:** Relay or opto outputs controlled by drive performing timer function. Timer is initiated by activating a digital input programmed as “Timer Start.”
 - **Counter function:** Relay or opto outputs controlled by drive performing counter function. Counter function is activated by a digital input programmed as “Counter Input.”
 - **Basic Logic:** Relay or opto outputs controlled by status of digital inputs programmed as “Logic Inputs.” Performs basic Boolean logic.
 - **StepLogic:** Logic-based steps using preset speed settings. Each step can be programmed for a specific speed, direction and accel/decel profile. Drive outputs can be used to indicate which step is being performed.



I/O

- **Two (2) Analog Inputs** (one unipolar and one bipolar) are independently isolated from the rest of the drive I/O. These inputs can be toggled between via a digital input.
- **Three (3) fixed and four (4) fully programmable Digital Inputs** provide application versatility.
- **One (1) Analog Output** is DIP switch selectable for either 0...10V or 0...20mA. This scalable, 10-bit output is suitable for metering or as a speed reference for another drive.
- **Two (2) Opto Outputs** and **one (1) form C relay output** can be used to indicate various drive, motor or logic conditions.

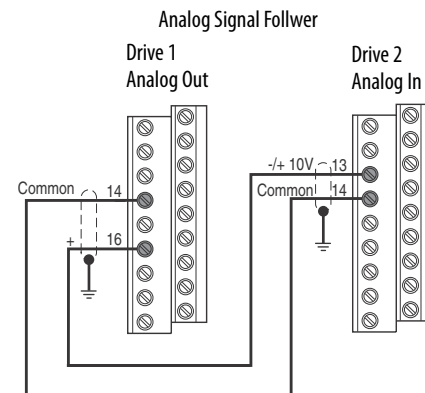

Communications

- Integral communication cards such as DeviceNet™, EtherNet/IP™, PROFIBUS™ DP, LonWorks® and, ControlNet™ can improve machine performance.
- The DSI Wireless Interface Module (WIM) provides a wireless communication interface between a Pocket PC, laptop computer or desktop computer equipped with Bluetooth® wireless technology, and any Allen-Bradley® product supporting the DSI™ protocol.
- Field installed option allows for future addition of stand-alone drives to a network.
- Online EDS file creation with RS NetWorx™ providing ease of set-up on a network.



Versatile Programming and Network Solutions

- PowerFlex 4 and PowerFlex 40 are compatible with any device that acts as a RTU Master and supports standard 03 and 06 RTU commands.
- A network can be configured using PowerFlex 40 drives with optional communication cards for high performance and flexible configuration capabilities.
 - BACnet
 - ControlNet
 - DeviceNet
 - EtherNet/IP
 - LonWorks
 - PROFIBUS DP
- A multi-drive solution can be reached using a single PowerFlex 40 DeviceNet option, with the ability for up to five drives to reside on one node.
- Integral RS485 communications enable the drives to be used in a multi-drop network configuration. A serial converter module (SCM) provides connectivity to any controller with a DF1 port. The SCM can be eliminated if the controller acts as a RTU Master.

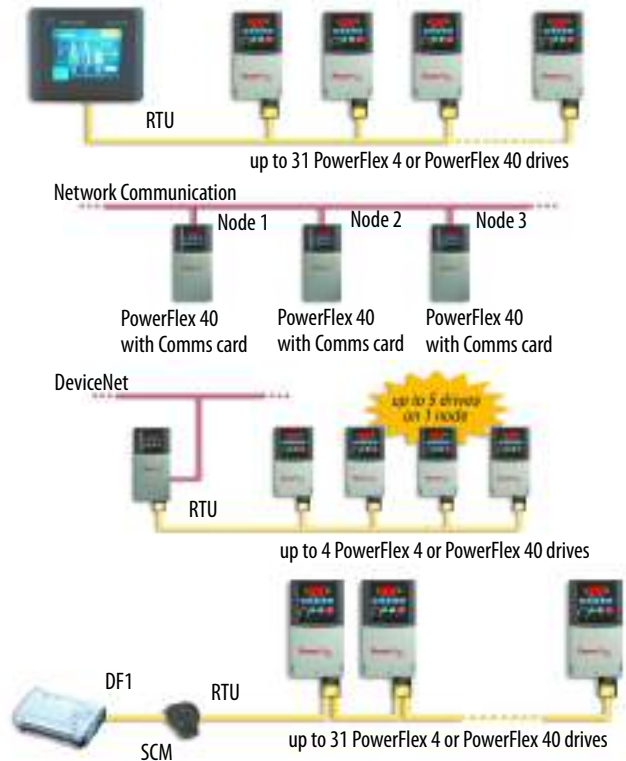

PC Programming Software

Through the use of a Serial Converter Module and DriveExplorer™ or DriveTools™ SP software, programming can be greatly simplified.

DriveExplorer Software

- View and modify drive and adapter parameters in a method similar to the file management capability of Microsoft Windows Explorer.
- Operate the drive via an on-screen Control Bar, which is a tool that allows you to start, stop, and change the speed reference of the drive.
- Save, restore and print parameter information.
- Compare current parameters with factory defaults or previously saved parameter values.
- Edit, upload and download parameters.

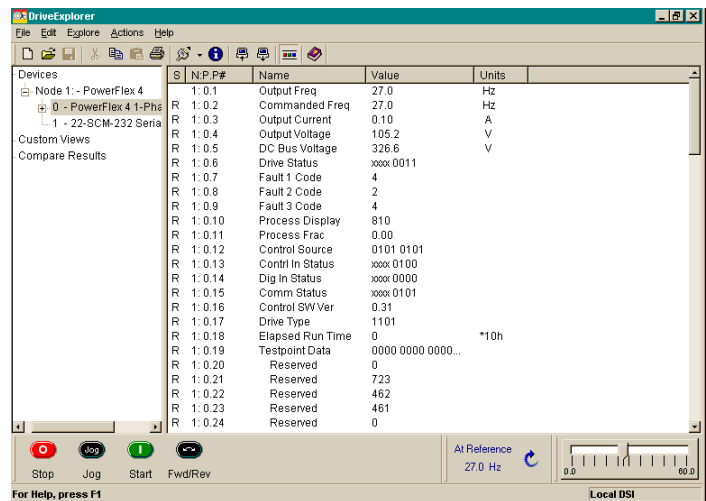

DriveTools SP Software

- Online and offline programming capability
- In-grid and dialog-based parameter editing
- Immediate visual indication of drive and communication status when viewing online drive
- Integrated HTML Help architecture

Use the chart below to assist in determining which product is most appropriate for an application.

	PowerFlex[®] 4	PowerFlex[®] 40
Feature		
Catalog Reference	22A	22B
	(1.1) 1.5 HP/115V, 1 ϕ	(1.1) 1.5 HP/115V, 1 ϕ
	(2.2) 3 HP/230V, 1 ϕ	(2.2) 3 HP/230V, 1 ϕ
	(3.7) 5 HP/230V, 3 ϕ	(7.5) 10 HP/230V, 3 ϕ
	(3.7) 5 HP/460V, 3 ϕ	(11.0) 15 HP/460V, 3 ϕ
Maximum (kW)HP Rating/Input Voltage		(11.0) 15 HP/600V, 3 ϕ
Overload Capacity	150% for 60 seconds 200% for 3 seconds	150% for 60 seconds 200% for 3 seconds
IP30, NEMA/UL Type 1 Option	●	●
IP66, NEMA/UL Type 4X/12 (Indoor)		● ⁽²⁾
EMC Filtering	Internal - 1 ϕ , 230V External - All 1 ϕ , 115V and 3 ϕ Ratings	Internal - 1 ϕ , 230V External - All 1 ϕ , 115V and 3 ϕ Ratings
DIN Rail Mounting Standard	●	● (Through 5 HP)
Integral Keypad with Speed Pot	●	●
Keypad - Remote LCD	●	●
Keypad CopyCat Function	●	●
Control Type	V/Hz	Sensorless Vector & V/Hz
Internal DB Transistor	● Not available on no brake models.	●
Preset Speeds	4	8
Carrier Frequency	2...16 kHz	2...16 kHz
Skip Frequency		●
Process Control Loop		● (PID)
StepLogic Functionality		●
Timer/Counter Functions		●
Control Voltage	24V sink/source	24V sink/source
Discrete Inputs	3 fixed for START/STOP/REV 2 fully programmable	3 fixed for START/STOP/REV 4 fully programmable
Analog Input - Unipolar	1 (0...10V or 4...20 mA)	2 (0...10V and 4...20 mA)
Analog Input - Bipolar		1 (+/- 10V) ⁽³⁾
Analog Response	2 Hz (500 ms)	100 Hz (10 ms)
Relay Output	1 - N.O./N.C. dry contact	1 - N.O./N.C. dry contact
Digital/Optocoupler Output		2
Analog Output		● (0...10V or 4...20 mA)
Integral RS485	●	●
RS232 (Requires use of Serial Converter Module)	●	●
BACnet	● ⁽¹⁾	●
ControlNet	● ⁽¹⁾	●
DeviceNet	● ⁽¹⁾	●
EtherNet/IP	● ⁽¹⁾	●
LonWorks	● ⁽¹⁾	●
PROFIBUS DP	● ⁽¹⁾	●

(1) With 22-XCOMM-DC-BASE External mounting kit.

(2) Frame B only.

(3) When using bipolar input, the 0...10V unipolar input cannot be used.

Catalog Number Explanation

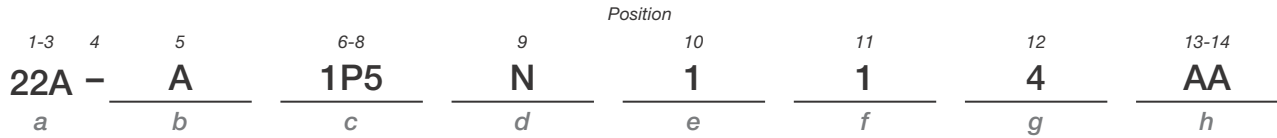

a

Drive	
Code	Type
22A	PowerFlex 4
22B	PowerFlex 40

b

Voltage Rating		
Code	Voltage	Ph.
V	120V ac	1
A	240V ac	1
B	240V ac	3
D	480V ac	3
E	600V ac	3

c1

Rating		
100-120V Single-Phase Input		
Code	Amps	kW (Hp)
2P3	2.3	0.4 (0.5)
5P0	5.0	0.75 (1.0)
6P0	6.0	1.1 (1.5)

c2

Rating		
200-240V Single-Phase Input		
Code	Amps	kW (Hp)
2P3	2.3	0.4 (0.5)
5P0	5.0	0.75 (1.0)
8P0	8.0	1.5 (2.0)
012	12	2.2 (3.0)

c3

Rating		
200-240V Three-Phase Input		
Code	Amps	kW (Hp)
2P3	2.3	0.4 (0.5)
5P0	5.0	0.75 (1.0)
8P0	8.0	1.5 (2.0)
012	12	2.2 (3.0)
017	17.5	3.7 (5.0)
024	24	5.5 (7.5)
033	33	7.5 (10)

c4

Rating		
380-480V Three-Phase Input		
Code	Amps	kW (Hp)
1P4	1.4	0.4 (0.5)
2P3	2.3	0.75 (1.0)
4P0	4.0	1.5 (2.0)
6P0	6.0	2.2 (3.0)
010	10.5	4.0 (5.0)
012	12	5.5 (7.5)
017	17	7.5 (10)
024	24	11 (15)

c5

Rating		
460-600V Three-Phase Input		
Code	Amps	kW (Hp)
1P7	1.7	0.75 (1.0)
3P0	3.0	1.5 (2.0)
4P2	4.2	2.2 (3.0)
6P6	6.6	4.0 (5.0)
9P9	9.9	5.5 (7.5)
012	12	7.5 (10)
019	19	11 (15)

d

Enclosure	
Code	Enclosure
C	IP66, NEMA/UL Type 4X *
F	Flange Mount - IP20, NEMA/UL Type Open
H	Replacement Plate Drive - IP20, NEMA/UL Type Open Contact factory for ordering information.
N	Panel Mount - IP20, NEMA/UL Type Open

* Check availability before ordering.

e

HIM	
Code	Interface Module
1	Fixed Keypad

f

Emission Class	
Code	Rating
0	Not Filtered
1	Filtered

g

Brake IGBT	
Code	Description
3	Without Brake
4	With Brake

h

Optional	
Code	Purpose
AA through ZZ	Reserved for custom firmware

Product Selection

Drive Ratings			PowerFlex 4			IP 20 Flange Mount ⁽²⁾	PowerFlex 40			IP 66, UL Type 4X Panel Mount	IP 20 Flange Mount ⁽²⁾
Input Voltage	kW	HP	Output Current	Catalog Number	Frame Size	Catalog Number	Output Current	Catalog Number	Frame Size	Catalog Number	Catalog Number
120V 50/60 Hz 1-Phase No Filter	0.2	0.25	1.5A	22A-V1P5N104	A	22A-V1P5F104	—	—	—	—	—
	0.4	0.5	2.3A	22A-V2P3N104	A	22A-V2P3F104	2.3A	22B-V2P3N104	B	22B-V2P3C104	22B-V2P3F104
	0.75	1.0	4.5A	22A-V4P5N104	B	22A-V4P5F104	5.0A	22B-V5P0N104	B	22B-V5P0C104	22B-V5P0F104
	1.1	1.5	6.0A	22A-V6P0N104	B	22A-V6P0F104	6.0A	22B-V6P0N104	B	22B-V6P0C104	22B-V6P0F104
240V 50/60 Hz 1-Phase NO BRAKE No Filter	0.2	0.25	1.4A	22A-A1P4N103	A	—	—	—	—	—	—
	0.4	0.5	2.1A	22A-A2P1N103	A	—	—	—	—	—	—
	0.75	1.0	3.6A	22A-A3P6N103	A	—	—	—	—	—	—
	1.5	2.0	6.8A	22A-A6P8N103	B	—	—	—	—	—	—
240V 50/60 Hz 1-Phase NO BRAKE With Integral "S Type" EMC Filter ⁽¹⁾	0.2	0.25	1.4A	22A-A1P4N113	A	—	—	—	—	—	—
	0.4	0.5	2.1A	22A-A2P1N113	A	—	—	—	—	—	—
	0.75	1.0	3.6A	22A-A3P6N113	A	—	—	—	—	—	—
	1.5	2.0	6.8A	22A-A6P8N113	B	—	—	—	—	—	—
240V 50/60 Hz 1-Phase With Integral "S Type" EMC Filter ⁽¹⁾	0.2	0.25	1.5A	22A-A1P5N114	A	—	—	—	—	—	—
	0.4	0.5	2.3A	22A-A2P3N114	A	—	2.3A	22B-A2P3N114	B	—	—
	0.75	1.0	4.5A	22A-A4P5N114	A	—	5.0A	22B-A5P0N114	B	—	—
	1.5	2.0	8.0A	22A-A8P0N114	B	—	8.0A	22B-A8P0N114	B	—	—
240V 50/60 Hz 1-Phase No Filter	0.2	0.25	1.5A	22A-A1P5N104	A	22A-A1P5F104	—	—	—	—	—
	0.4	0.5	2.3A	22A-A2P3N104	A	22A-A2P3F104	2.3A	22B-A2P3N104	B	22B-A2P3C104	22B-A2P3F104
	0.75	1.0	4.5A	22A-A4P5N104	A	22A-A4P5F104	5.0A	22B-A5P0N104	B	22B-A5P0C104	22B-A5P0F104
	1.5	2.0	8.0A	22A-A8P0N104	B	22A-A8P0F104	8.0A	22B-A8P0N104	B	22B-A8P0C104	22B-A8P0F104
240V 50/60 Hz 3-Phase No Filter	0.2	0.25	1.5A	22A-B1P5N104	A	22A-B1P5F104	—	—	—	—	—
	0.4	0.5	2.3A	22A-B2P3N104	A	22A-B2P3F104	2.3A	22B-B2P3N104	B	22B-B2P3C104	22B-B2P3F104
	0.75	1.0	4.5A	22A-B4P5N104	A	22A-B4P5F104	5.0A	22B-B5P0N104	B	22B-B5P0C104	22B-B5P0F104
	1.5	2.0	8.0A	22A-B8P0N104	A	22A-B8P0F104	8.0A	22B-B8P0N104	B	22B-B8P0C104	22B-B8P0F104
	2.2	3.0	12.0A	22A-B012N104	B	22A-B012F104	12.0A	22B-B012N104	B	22B-B012C104	22B-B012F104
	3.7	5.0	17.5A	22A-B017N104	B	22A-B017F104	17.5A	22B-B017N104	B	22B-B017C104	22B-B017F104
	5.5	7.5	—	—	—	—	24.0A	22B-B024N104	C	—	22B-B024F104
	7.5	10.0	—	—	—	—	33.0A	22B-B033N104	C	—	22B-B033F104
480V 50/60 Hz 3-Phase No Filter	0.4	0.5	1.4A	22A-D1P4N104	A	22A-D1P4F104	1.4A	22B-D1P4N104	B	22B-D1P4C104	22B-D1P4F104
	0.75	1.0	2.3A	22A-D2P3N104	A	22A-D2P3F104	2.3A	22B-D2P3N104	B	22B-D2P3C104	22B-D2P3F104
	1.5	2.0	4.0A	22A-D4P0N104	A	22A-D4P0F104	4.0A	22B-D4P0N104	B	22B-D4P0C104	22B-D4P0F104
	2.2	3.0	6.0A	22A-D6P0N104	B	22A-D6P0F104	6.0A	22B-D6P0N104	B	22B-D6P0C104	22B-D6P0F104
	3.7	5.0	8.7A	22A-D8P7N104	B	22A-D8P7F104	—	—	—	—	—
	4.0	5.0	—	—	—	—	10.5A	22B-D010N104	B	22B-D010C104	22B-D010F104
	5.5	7.5	—	—	—	—	12.0A	22B-D012N104	C	—	22B-D012F104
	7.5	10.0	—	—	—	—	17.0A	22B-D017N104	C	—	22B-D017F104
	11.0	15.0	—	—	—	—	24.0A	22B-D024N104	C	—	22B-D024F104 ⁽³⁾
600V 50/60 Hz 3-Phase No Filter	0.75	1.0	—	—	—	—	1.7A	22B-E1P7N104	B	22B-E1P7C104	22B-E1P7F104
	1.5	2.0	—	—	—	—	3.0A	22B-E3P0N104	B	22B-E3P0C104	22B-E3P0F104
	2.2	3.0	—	—	—	—	4.2A	22B-E4P2N104	B	22B-E4P2C104	22B-E4P2F104
	4.0	5.0	—	—	—	—	6.6A	22B-E6P6N104	B	22B-E6P6C104	22B-E6P6F104
	5.5	7.5	—	—	—	—	9.9A	22B-E9P9N104	C	—	22B-E9P9F104
	7.5	10.0	—	—	—	—	12.0A	22B-E012N104	C	—	22B-E012F104
	11.0	15.0	—	—	—	—	19.0A	22B-E019N104	C	—	22B-E019F104

(1) This filter is suitable for use with a cable length of at least 10 meters for Class A and 1 meter for Class B environments.

(2) Meets IP40/54/65 (NEMA 1/12/4/4X) when installed in an enclosure of like rating.

(3) Requires use of external DC Bus Inductor or AC Line Reactor.

Shaded areas are applicable to PowerFlex 40 only.

User Installed Options

IP30/NEMA 1/UL Type 1 Conversion Kit

Item	Description	Drive Frame	PowerFlex 4	PowerFlex 40
			Catalog Number ⁽¹⁾	Catalog Number ⁽¹⁾
IP30/NEMA 1/UL Type 1 Kit	Field installed kit. Converts drive to IP30/NEMA 1/UL Type 1 enclosure. Includes conduit box with mounting screws and plastic top panel.	A	22-JBAA	–
		B	22-JBAB	22-JBAB
		C	–	22-JBAC
IP30/NEMA 1/UL Type 1 Kit with Communication Option	Field installed kit. Converts drive to IP30/NEMA 1/UL Type 1 enclosure. Includes communication option conduit box with mounting screws and plastic top panel.	B	–	22-JBCB
		C	–	22-JBCC

(1) For pricing information, refer to the PowerFlex 4 Price List, publication 22A-PL001 and PowerFlex 40 Price List, publication 22B-PL001.

Human Interface Module Option Kits and Accessories

Item	Description	Catalog Number ⁽¹⁾
Remote Human Interface Modules (HIMs)	LCD Display, Remote Panel Mount, Digital Speed Control, CopyCat capable, IP66 (NEMA Type 4X/12) indoor use only. Includes 2.0 meter cable.	22-HIM-C2S
	LCD Display, Remote Handheld, Digital Speed Control, Full Numeric Keypad, CopyCat capable, IP30 (NEMA Type 1). Includes 1.0 meter cable. Can be panel mounted with optional Bezel Kit.	22-HIM-A3
	Remote Handheld, Wireless Interface Module with <i>Bluetooth</i> ® technology, IP30 (NEMA Type 1). Panel Mount with optional Bezel Kit.	22-WIM-N1
	Remote Panel Mount, Wireless Interface Module with <i>Bluetooth</i> ® technology, IP66 (NEMA Type 4X/12) indoor use only.	22-WIM-N4S
Bezel Kit	Panel Mount for LCD Display, Remote Handheld unit, IP30 (NEMA Type 1). Includes a 22-RJ45CBL-C20 cable.	22-HIM-B1
DSI HIM Cable	DSI HIM Cable (DSI HIM to RJ45 cable) <ul style="list-style-type: none"> 1.0 Meter (3.3 Feet) 2.9 Meter (9.51 Feet) 	22-HIM-H10 22-HIM-H30

(1) For pricing information, refer to the PowerFlex 4 Price List, publication 22A-PL001 and PowerFlex 40 Price List, publication 22B-PL001.

Communication Option Kits

Item	Description	Catalog Number ⁽¹⁾
Serial Converter Module (RS485 to RS232)	Provides serial communication via DF1 protocol for use with DriveExplorer™ and DriveExecutive™ software. Smart Self-powered Serial Converter (RS-232) includes: <ul style="list-style-type: none"> DSI to RS232 serial converter DriveExplorer Lite Version 3.01 or later 1203-SFC and 22-RJ45CBL-C20 Cables 	22-SCM-232
Serial Cable	2.0 meter serial cable with a locking low profile connector to connect to the serial converter and a 9-pin sub-miniature D female connector to connect to a computer.	1203-SFC
Null Cable Converter	For use when connecting the serial converter to DriveExplorer on a handheld PC.	1203-SNM
Universal Serial Bus™ (USB) Converter	Provides a direct, isolated USB connection for use with DriveExplorer and DriveExecutive software. Includes 2.0 meter USB cable, 20-HIM-H10 and 22-HIM-H10 cables.	1203-USB
DSI Cable	2.0 meter RJ45 to RJ45 cable, male to male connectors.	22-RJ45CBL-C20
Splitter Cable	RJ45 one to two port splitter cable.	AK-U0-RJ45-SC1
Terminating Resistors	RJ45 120 Ohm resistor (2 pieces).	AK-U0-RJ45-TR1
Terminal Block	RJ45 Two position terminal block (6 pieces).	AK-U0-RJ45-TB2P
External DSI Communications Kit	External communications kit for 22-COMM Communication Adapters. Multi-Drive capability allows connectivity for up to 5 drives.	22-XCOMM-DC-BASE
External Comms Power Supply	Optional 100...240V AC power supply for external DSI communications kit.	20-XCOMM-AC-PS1
Communication Adapters	Embedded communication option for use with the PowerFlex family of drives. Requires a Communication Adapter Cover (Ordered Separately). <ul style="list-style-type: none"> BACnet ControlNet DeviceNet EtherNet/IP LonWorks PROFIBUS DP 	22-COMM-B 22-COMM-C 22-COMM-D 22-COMM-E 22-COMM-L 22-COMM-P
Compact I/O Module	Provides 3 channels that can be individually configured for Single, Multi-Drive, and Modbus RTU modes.	1769-SM2
Communication Adapter Covers	Houses the optional communication adapters. These covers add 25 mm (0.98 in.) to the overall depth of the drive. <ul style="list-style-type: none"> PowerFlex 40 Drive Frame B PowerFlex 40 Drive Frame C 	22B-CCB 22B-CCC

(1) For pricing information, refer to the PowerFlex 4 Price List, publication 22A-PL001 and PowerFlex 40 Price List, publication 22B-PL001.

Shaded areas are applicable to PowerFlex 40 only.

PC Programming Software

Item	Description	Catalog Number
DriveTools SP Software	"Windows" based software package that provides an intuitive means for monitoring or configuring Allen-Bradley drives and communications adapters online and offline. Compatibility: Windows 98, ME, NT, 4.0 (Service Pack 3 or later), 2000 and XP. ⁽¹⁾	9303-4DTE01ENE
DriveExplorer™ Software	"Windows" based software package that provides an intuitive means for monitoring or configuring Allen-Bradley drives and communications adapters online and offline. Compatibility: Windows 98, ME, NT, 4.0 (Service Pack 3 or later), 2000 and XP. ⁽¹⁾	9306-4EXP01ENE

(1) See www.ab.com/drives/ for support devices.

DC Bus Inductors

Input Voltage	kW	HP	Amps	Inductance (mh)	MTE Catalog Number
240V 50/60 Hz 3-Phase	5.5	7.5	32	0.85	32RB001
	7.5	10.0	40	0.5	40RB001
480V 50/60 Hz 3-Phase	5.5	7.5	18	3.75	18RB004
	7.5	10.0	25	4.0	25RB005
	11.0	15.0	32	2.68	32RB003
600V 50/60 Hz 3-Phase	5.5	7.5	12	6.0	12RB004
	7.5	10.0	18	6.0	18RB005
	11.0	15.0	25	4.0	25RB005

Shaded areas are applicable to PowerFlex 40 only.

Dynamic Brake Resistors

Drive Ratings			PowerFlex 4	PowerFlex 40
Input Voltage	kW	HP	Catalog Number ⁽¹⁾	Catalog Number ⁽¹⁾
120V 50/60 Hz 1-Phase	0.2	0.25	AK-R2-091P500	–
	0.4	0.5	AK-R2-091P500	–
	0.75	1.0	AK-R2-091P500	
	1.1	1.5	AK-R2-091P500	–
240V 50/60 Hz 1-Phase	0.2	0.25	AK-R2-091P500	–
	0.4	0.5	AK-R2-091P500	–
	0.75	1.0	AK-R2-091P500	
	1.5	2.0	AK-R2-091P500	
	2.2	3.0	–	AK-R2-047P500
240V 50/60 Hz 3-Phase	0.2	0.25	AK-R2-091P500	–
	0.4	0.5	AK-R2-091P500	–
	0.75	1.0	AK-R2-091P500	
	1.5	2.0	AK-R2-091P500	
	2.2	3.0	AK-R2-047P500	
	3.7	5.0	AK-R2-047P500	
	5.5	7.5	–	AK-R2-030P1K2
	7.5	10.0	–	AK-R2-030P1K2
480V 50/60 Hz 3-Phase	0.4	0.5	AK-R2-360P500	
	0.75	1.0	AK-R2-360P500	
	1.5	2.0	AK-R2-360P500	
	2.2	3.0	AK-R2-120P1K2	
	4.0	5.0	AK-R2-120P1K2	
	5.5	7.5	–	AK-R2-120P1K2
	7.5	10.0	–	AK-R2-120P1K2
	11.0	15.0	–	AK-R2-120P1K2 ⁽²⁾
600V 50/60 Hz 3-Phase No Filter	0.75	1.0	–	AK-R2-360P500
	1.5	2.0	–	AK-R2-360P500
	2.2	3.0	–	AK-R2-120P1K2
	4.0	5.0	–	AK-R2-120P1K2
	5.5	7.5	–	AK-R2-120P1K2
	7.5	10.0	–	AK-R2-120P1K2
	11.0	15.0	–	AK-R2-120P1K2 ⁽²⁾

- (1) Resistors listed in this table are rated for a minimum 5% duty cycle. See publication PFLEX-AT001 for additional information.
- (2) Requires two resistors wired in parallel.

3% Line Reactors

Input Voltage	kW	HP	Fundamental Amps	Max Continuous Amps	Inductance mh	Watts Loss	Catalog Number ⁽¹⁾
240V 50/60 Hz 3-Phase	0.2	0.25	2	3	12.0	7.5 W	1321-3R2-A
	0.4	0.5	4	6	12.0	21 W	1321-3R4-D
	0.75	1.0	8	12	3.0	29 W	1321-3R8-B
	1.5	2.0	8	12	1.5	19.5 W	1321-3R8-A
	2.2	3.0	12	18	1.25	26 W	1321-3R12-A
	3.7	5.0	18	27	0.8	36 W	1321-3R18-A
	5.5	7.5	25	37.5	0.5	48 W	1321-3R25-A
	7.5	10.0	35	52.5	0.4	49 W	1321-3R35-A
480V 50/60 Hz 3-Phase	0.4	0.5	2	3	20.0	11.3 W	1321-3R2-B
	0.75	1.0	4	6	9.0	20 W	1321-3R4-C
	1.5	2.0	4	6	6.5	20 W	1321-3R4-B
	2.2	3.0	8	12	5.0	25.3 W	1321-3R8-C
	3.7	5.0	8	12	3.0	29 W	1321-3R8-B
	4.0	5.0	12	18	2.5	31 W	1321-3R12-B
	5.5	7.5	12	18	2.5	31 W	1321-3R12-B
	7.5	10.0	18	27	1.5	43 W	1321-3R18-B
	11.0	15.0	25	37.5	1.2	52 W	1321-3R25-B
	600V 50/60 Hz 3-Phase No Filter	0.75	1.0	2	3	20.0	11.3 W
1.5		2.0	4	6	6.5	20 W	1321-3R4-B
2.2		3.0	4	6	6.5	20 W	1321-3R4-B
4.0		5.0	8	12	5.0	25.3 W	1321-3R8-C
5.5		7.5	12	18	2.5	31 W	1321-3R12-B
7.5		10.0	12	18	2.5	31 W	1321-3R12-B
11.0		15.0	18	27	1.5	43 W	1321-3R18-B

- (1) Catalog numbers listed are for 3% impedance open style units. NEMA Type 1 and 5% impedance reactor types are also available. Refer to publication 1321-TD001.

Shaded areas are applicable to PowerFlex 40 only.

PowerFlex 4 EMC Filters

Drive Ratings			S Type Filter	L Type Filter
Input Voltage	kW	HP	Catalog Number ⁽¹⁾	Catalog Number ⁽³⁾
120V 50/60 Hz 1-Phase	0.2	0.25	—	22-RF010-AL
	0.4	0.5	—	22-RF010-AL
	0.75	1.0	—	22-RF018-BL
240V 50/60 Hz 1-Phase	0.2	0.25	⁽²⁾	22-RF010-AL
	0.4	0.5	⁽²⁾	22-RF010-AL
	0.75	1.0	⁽²⁾	22-RF010-AL
	1.5	2.0	⁽²⁾	22-RF018-BL
240V 50/60 Hz 3-Phase	0.2	0.25	22-RF9P5-AS	22-RF9P5-AL
	0.4	0.5	22-RF9P5-AS	22-RF9P5-AL
	0.75	1.0	22-RF9P5-AS	22-RF9P5-AL
	1.5	2.0	22-RF9P5-AS	22-RF9P5-AL
	2.2	3.0	22-RF021-BS	22-RF021-BL
	3.7	5.0	22-RF021-BS	22-RF021-BL
480V 50/60 Hz 3-Phase	0.4	0.5	22-RF5P7-AS	22-RF5P7-AL
	0.75	1.0	22-RF5P7-AS	22-RF5P7-AL
	1.5	2.0	22-RF5P7-AS	22-RF5P7-AL
	2.2	3.0	22-RF012-BS	22-RF012-BL
	4.0	5.0	22-RF012-BS	22-RF012-BL

PowerFlex 40 EMC Filters

Drive Ratings			S Type Filter	L Type Filter
Input Voltage	kW	HP	Catalog Number ⁽¹⁾	Catalog Number ⁽³⁾
120V 50/60 Hz 1-Phase	0.4	0.5	—	22-RF018-BL
	0.75	1.0	—	22-RF018-BL
	1.1	1.5	—	22-RF018-BL
240V 50/60 Hz 1-Phase	0.4	0.5	⁽²⁾	22-RF018-BL
	0.75	1.0	⁽²⁾	22-RF018-BL
	1.5	2.0	⁽²⁾	22-RF018-BL
	2.2	3.0	⁽²⁾	22-RF025-CL
240V 50/60 Hz 3-Phase	0.4	0.5	22-RF021-BS ⁽⁴⁾	22-RF021-BL
	0.75	1.0	22-RF021-BS ⁽⁴⁾	22-RF021-BL
	1.5	2.0	22-RF021-BS ⁽⁴⁾	22-RF021-BL
	2.2	3.0	22-RF021-BS ⁽⁴⁾	22-RF021-BL
	3.7	5.0	22-RF021-BS ⁽⁴⁾	22-RF021-BL
	5.5	7.5	22-RF034-CS	22-RF034-CL
	7.5	10.0	22-RF034-CS	22-RF034-CL
480V 50/60 Hz 3-Phase	0.4	0.5	22-RF012-BS	22-RF012-BL
	0.75	1.0	22-RF012-BS	22-RF012-BL
	1.5	2.0	22-RF012-BS	22-RF012-BL
	2.2	3.0	22-RF012-BS	22-RF012-BL
	4.0	5.0	22-RF012-BS	22-RF012-BL
	5.5	7.5	22-RF018-CS	22-RF018-CL
	7.5	10.0	22-RF018-CS	22-RF018-CL
	11.0	15.0	22-RF026-CS	22-RF026-CL
	600V 50/60 Hz 3-Phase	0.75	1.0	—
1.5		2.0	—	22-RF8P0-BL
2.2		3.0	—	22-RF8P0-BL
4.0		5.0	—	22-RF8P0-BL
5.5		7.5	—	22-RF015-CL
7.5		10.0	—	22-RF015-CL
11.0		15.0	—	22-RF024-CL

- (1) This filter is suitable for use with a cable length up to 10 meters for Class A and 1 meter for Class B environments.
 (2) Drives are available in these ratings with internal "S Type" filters.
 (3) This filter is suitable for use with a cable length up to 100 meters for Class A and 5 meters for Class B environments.
 (4) Filter must be Series B or later.

PowerFlex 4 & 40 Spare Parts

Description	Catalog Number
PowerFlex 4 Fan Replacement Kit - Frame A	SK-U1-FAN1-A1
PowerFlex 4/40 Fan Replacement Kit - Frame B, 1 Fan	SK-U1-FAN1-B1
PowerFlex 4/40 Fan Replacement Kit - Frame B, 2 Fans	SK-U1-FAN2-B1
PowerFlex 40 Fan Replacement Kit - Frame C, 1 Fan	SK-U1-FAN1-C1
PowerFlex 40 Fan Replacement Kit - Frame C, 1 Fan (15 HP)	SK-U1-FAN1-C2
PowerFlex 4 Frame A Cover with Power Terminal Guard	SK-U1-ACVR1-A1
PowerFlex 4 Frame B Cover with Power Terminal Guard	SK-U1-ACVR1-B1
PowerFlex 40 Frame B Cover with Power Terminal Guard	SK-U1-BCVR1-B1
PowerFlex 40 Frame C Cover with Power Terminal Guard	SK-U1-BCVR1-C1

Shaded areas are applicable to PowerFlex 40 only.

Installation Considerations

PowerFlex 4 and 40 drives have the following built in protective features to help simplify installation.

- Ground fault protection while starting and running ensures reliable operation
- Electronic motor overload protection increases motor life
- Removable MOV to ground ensures compatibility with ungrounded systems
- 6kV transient protection provides increased robustness for 380...480V system voltages

There are many other factors that must be considered for optimal performance in any given application. The block diagram below highlights the primary installation considerations. Consult the PowerFlex 4 or PowerFlex 40 User Manual, Publications 22A-UM001 or 22B-UM001 available online at www.rockwellautomation.com/literature, for detailed recommendations on input power conditioning, CE conformance (EMC filtering), dynamic braking, reflected wave protection, motor cable types and motor cable distances.

Block Diagram

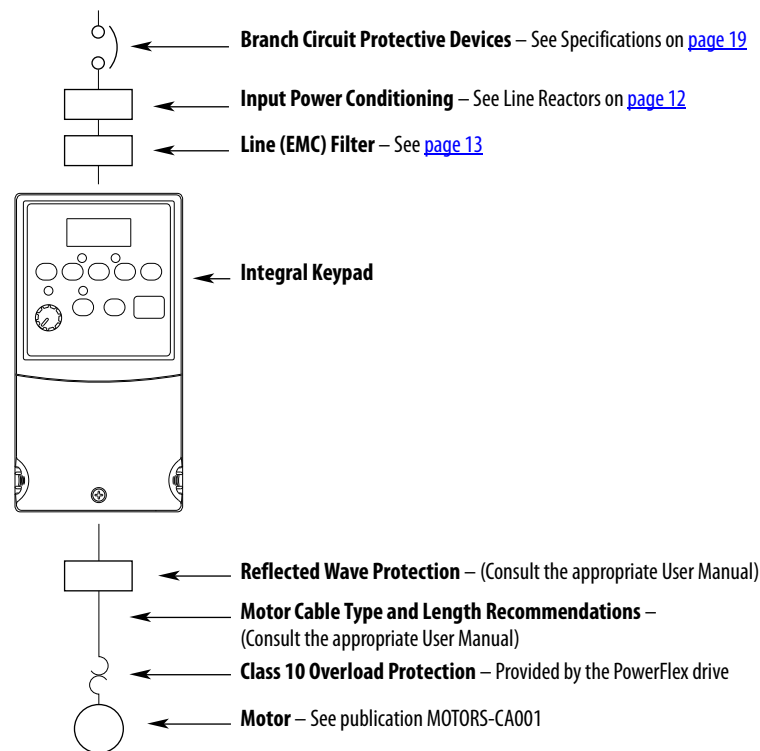

Drive Ratings — PowerFlex 40

Catalog Number	Output Ratings		Input Ratings			Branch Circuit Protection				Power Dissipation	
	kW (HP)	Amps	Voltage Range	kVA	Amps	Fuses ⁽²⁾	140M Motor Protectors ^{(3) (4)}	Contactors	Min. Enclosure Volume ⁽⁵⁾ (in. ³)	Internal	Total
100...120V AC – 1-Phase Input, 0...230V 3-Phase Output											
22B-V2P3N104	0.4 (0.5)	2.3	90...132	1.15	9.0	15	140M-C2E-C16	100-C12	1655	9	30
22B-V5P0N104	0.75 (1.0)	5.0	90...132	2.45	20.3	35	140M-D8E-C20	100-C23	1655	12	55
22B-V6P0N104	1.1 (1.5)	6.0	90...132	3.0	24.0	40	140M-F8E-C32	100-C37	1655	12	70
200...240V AC – 1-Phase Input, 0...230V 3-Phase Output ⁽¹⁾											
22B-A2P3N104	0.4 (0.5)	2.3	180...264	1.15	6.0	10	140M-C2E-B63	100-C09	1655	9	30
22B-A5P0N104	0.75 (1.0)	5.0	180...264	2.45	12.0	20	140M-C2E-C16	100-C12	1655	12	55
22B-A8P0N104	1.5 (2.0)	8.0	180...264	4.0	18.0	30	140M-D8E-C20	100-C23	1655	16	80
22B-A012N104	2.2 (3.0)	12.0	180...264	5.5	25.0	40	140M-F8E-C32	100-C37	2069	11	110
200...240V AC – 3-Phase Input, 0...230V 3-Phase Output											
22B-B2P3N104	0.4 (0.5)	2.3	180...264	1.15	2.5	6	140M-C2E-B40	100-C07	1655	9	30
22B-B5P0N104	0.75 (1.0)	5.0	180...264	2.45	5.7	10	140M-C2E-C10	100-C09	1655	12	55
22B-B8P0N104	1.5 (2.0)	8.0	180...264	4.0	9.5	15	140M-C2E-C16	100-C12	1655	16	80
22B-B012N104	2.2 (3.0)	12.0	180...264	5.5	15.5	25	140M-C2E-C16	100-C23	1655	16	115
22B-B017N104	3.7 (5.0)	17.5	180...264	8.6	21.0	35	140M-F8E-C25	100-C23	1655	16	165
22B-B024N104	5.5 (7.5)	24.0	180...264	11.8	26.1	40	140M-F8E-C32	100-C37	2069	28	225
22B-B033N104	7.5 (10.0)	33.0	180...264	16.3	34.6	60	140M-F8E-C45	100-C60	2069	28	290
380...480V AC – 3-Phase Input, 0...460V 3-Phase Output											
22B-D1P4N104	0.4 (0.5)	1.4	342...528	1.4	1.8	3	140M-C2E-B25	100-C07	1655	15	30
22B-D2P3N104	0.75 (1.0)	2.3	342...528	2.3	3.2	6	140M-C2E-B40	100-C07	1655	13	40
22B-D4P0N104	1.5 (2.0)	4.0	342...528	4.0	5.7	10	140M-C2E-B63	100-C09	1655	13	60
22B-D6P0N104	2.2 (3.0)	6.0	342...528	5.9	7.5	15	140M-C2E-C10	100-C09	1655	17	90
22B-D010N104	4.0 (5.0)	10.5	342...528	10.3	13.0	20	140M-C2E-C16	100-C23	1655	14	150
22B-D012N104	5.5 (7.5)	12.0	342...528	11.8	14.2	25	140M-D8E-C20	100-C23	2069	23	160
22B-D017N104	7.5 (10.0)	17.0	342...528	16.8	18.4	30	140M-D8E-C20	100-C23	2069	24	200
22B-D024N104	11.0 (15.0)	24.0	342...528	23.4	26.0	50	140M-F8E-C32	100-C43	2069	25	285
460...600V AC – 3-Phase Input, 0...575V 3-Phase Output											
22B-E1P7N104	0.75 (1.0)	1.7	414...660	2.1	2.3	6	140M-C2E-B25	100-C09	1655	13	40
22B-E3P0N104	1.5 (2.0)	3.0	414...660	3.65	3.8	6	140M-C2E-B40	100-C09	1655	13	60
22B-E4P2N104	2.2 (3.0)	4.2	414...660	5.2	5.3	10	140M-D8E-B63	100-C09	1655	17	90
22B-E6P6N104	4.0 (5.0)	6.6	414...660	8.1	8.3	15	140M-D8E-C10	100-C09	1655	14	150
22B-E9P9N104	5.5 (7.5)	9.9	414...660	12.1	11.2	20	140M-D8E-C16	100-C16	2069	23	160
22B-E012N104	7.5 (10.0)	12.2	414...660	14.9	13.7	25	140M-D8E-C16	100-C23	2069	24	200
22B-E019N104	11.0 (15.0)	19.0	414...660	23.1	24.1	40	140M-F8E-C25	100-C30	2069	25	285





(1) 200...240V AC - 1-Phase drives are also available with an integral EMC filter. Catalog suffix changes from N104 to N114 or N103 to N113.

(2) Recommended Fuse Type: UL Class J, CC, T or Type BS88; 600V (550V) or equivalent.

(3) The AIC ratings of the Bulletin 140M Motor Protector Circuit Breakers may vary. See [Bulletin 140M Motor Protection Circuit Breakers Application Ratings](#).

(4) Manual Self-Protected (Type E) Combination Motor Controller, UL listed for 208 Wye or Delta, 240 Wye or Delta, 480Y/277 or 600Y/347. Not UL listed for use on 480V or 600V Delta/Delta, corner ground, or high-resistance ground systems.

(5) When using a Manual Self-Protected (Type E) Combination Motor Controller, the drive must be installed in a ventilated or non-ventilated enclosure with the minimum volume specified in this column. Application specific thermal considerations may require a larger enclosure.

Input/Output Ratings	Output Frequency: Efficiency:	PowerFlex 4: 0...240 Hz (Programmable) PowerFlex 40: 0...400 Hz (Programmable) 97.5% (Typical)
Approvals	 UL508C  CSA C 22.2 No. 14  EN 61800-3  CE <small>LV Directive 73/23/EEC LV: EN 50178, EN 60204 EMC Directive 89/336/EEC EMC: EN 61800-3</small>	
Control Inputs	Digital SRC (Source) Mode: SNK (Sink) Mode: Analog 4...20 mA Analog: 0...10V DC Analog: External Pot:	Input Current = 6 mA 18...24V = On, 0...6V = Off 0...6V = On, 18...24V = Off 250 ohm input impedance 100k ohm input impedance 1...10k ohms, 2 Watt minimum
Control Output – Programmable Output (form C relay)	Resistive Rating Opto Outputs (PF 40): Analog Outputs (PF 40): Inductive Rating Opto Outputs (PF 40): Analog Outputs (PF 40):	3.0A at 30V DC, 3.0A at 125V AC, 3.0A at 240V AC 30V DC, 50 mA 10-bit, 0...10V, 1k ohm minimum 0.5A at 30V DC, 0.5A at 125V AC, 0.5A at 240V AC Non-inductive 10 bit, 4...20 mA, 525 ohm maximum
Fuses and Circuit Breakers	Recommended Fuse Type: Recommended Circuit Breakers:	UL Class J, CC, T or Type B588; 600V (550V) or equivalent. HMCP circuit breaker or equivalent.
Protective Features	Motor Protection: Overcurrent: Control Ride Through: Faultless Power Ride Through: Over Voltage: Under Voltage:	1 ¹ / ₂ Overload Protection, 150% for 60 sec., 200% for 3 sec. (provides Class 10 protection) 200% hardware limit, 300% instantaneous fault Minimum Ride Through is 0.5 sec. - typical value is 2 seconds 100 milliseconds 100...120V AC Input – Trip occurs at 405V DC bus voltage (= 150V AC incoming line) 200...240V AC Input – Trip occurs at 405V DC bus voltage (= 290V AC incoming line) 380...480V AC Input – Trip occurs at 810V DC bus voltage (= 575V AC incoming line) 460...600V AC Input (PF 40) – Trip occurs at 1005V DC bus voltage (= 711V AC incoming line) 100...120V AC Input – Trip occurs at 210V DC bus voltage (= 75V AC incoming line) 200...240V AC Input – Trip occurs at 210V DC bus voltage (= 150V AC incoming line) 380...480V AC Input – Trip occurs at 390V DC bus voltage (= 275V AC incoming line) 460...600V AC Input (PF 40) If P042 = 1 “High Voltage” trip occurs at 487V DC bus voltage (344V AC incoming line); If P042 = 0 “Low Voltage” trip occurs at 390V DC bus voltage (275V AC incoming line)
Dynamic Braking Environment	Internal brake IGBT included with all ratings except No Brake drives (Cat. Nos. 22A-AxPxN103 or 22A-AxPxN113). Refer to page 11 for ordering information. Altitude: Ambient Operating Temperature: Cooling Method: Storage Temperature: Atmosphere: Relative Humidity: Shock (operating): Vibration (operating):	1000 m (3300 ft.) maximum without derating IP20, NEMA/UL Type Open: -10 to 50 degrees C (14 to 122 degrees F) IP30, NEMA/UL Type 1: -10 to 40 degrees C (14 to 104 degrees F) IP66, NEMA/UL Type 4X/12 (PF 40): -10 to 40 degrees C (14 to 104 degrees F) Fan, all drive ratings -40 to 85 degrees C (-40 to 185 degrees F) Important: Drive must not be installed in an area where the ambient atmosphere contains volatile or corrosive gas, vapors or dust. If the drive is not going to be installed for a period of time, it must be stored in an area where it will not be exposed to a corrosive atmosphere. 0 to 95% non-condensing 15G peak for 11ms duration (±1.0ms) 1G peak, 5 to 2000 Hz
Control	Carrier Frequency: Frequency Accuracy: Speed Regulation: Stop Modes: Accel/Decel: Intermittent Overload: Electronic Motor Overload Protection:	2...16 kHz. Drive rating based on 4 kHz. Digital Input: Within ±0.05% of set output frequency. Analog Input: Within 0.5% of maximum output frequency. Analog Output (PF 40): ±2% of full scale, 10-bit resolution. Open Loop with Slip Compensation: ±2% of base speed across a 40:1 speed range. (PF 40): 1% of base speed across a 60:1 speed range. Multiple programmable stop modes including - Ramp, Coast, DC-Brake, Ramp-to-Hold and S Curve. Two independently programmable accel and decel times. Each time may be programmed from 0...600 seconds in 0.1 second increments. 150% overload capability for up to 1 minute, 200% overload capability for up to 3 seconds. Provides class 10 motor overload protection according to NEC article 430 and motor over-temperature protection according to NEC article 430.126 (A) (2). UL 508C File 29572.
Electrical	Voltage Tolerance: Frequency Tolerance: Displacement Power Factor: Maximum Short Circuit Rating:	120V, 200...240V, 380...480V, 460...600V: ±10% 48...63 Hz 0.98 across entire speed range 100,000 Amps symmetrical

Product Dimensions

Approximate Dimensions

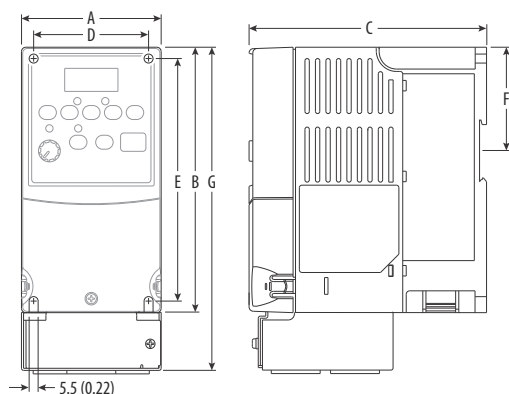

Dimensions are in millimeters and (inches). Weights are in kilograms and (pounds).

Frame	A	B ⁽¹⁾	C	D	E	F	G ⁽²⁾	Shipping Weight
A	80 (3.15)	152 (5.98)	136 (5.35)	67 (2.64)	140 (5.51)	59.3 (2.33)	185 (7.28)	1.4 (3.1)
B	100 (3.94)	180 (7.09)	136 (5.35)	87 (3.43)	168 (6.61)	87.4 (3.44)	213 (8.39)	2.2 (4.9)
C	130 (5.1)	260 (10.2)	180 (7.1)	116 (4.57)	246 (9.7)	—	320 (12.6)	4.3 (9.5)

(1) Overall height of standard IP 20/Open Type Drive.

(2) Overall height of drive with IP 30/NEMA 1/UL Type 1 option kit installed.

Ratings are in kW and (HP).

PowerFlex 4 — Frame	120V AC – 1-Phase	240V AC – 1-Phase	240V AC – 3-Phase	480V AC – 3-Phase
A	0.2 (0.25) 0.4 (0.5)	0.2 (0.25) 0.4 (0.5) 0.75 (1.0)	0.2 (0.25) 0.4 (0.5) 0.75 (1.0) 1.5 (2.0)	0.4 (0.5) 0.75 (1.0) 1.5 (2.0)
B	0.75 (1.0) 1.1 (1.5)	1.5 (2.0)	2.2 (3.0) 3.7 (5.0)	2.2 (3.0) 3.7 (5.0)

PowerFlex 40 — Frame	120V AC – 1-Phase	240V AC – 1-Phase	240V AC – 3-Phase	480V AC – 3-Phase	600V AC – 3-Phase
B	0.4 (0.5) 0.75 (1.0) 1.1 (1.5)	0.4 (0.5) 0.75 (1.0) 1.5 (2.0)	0.4 (0.5) 0.75 (1.0) 1.5 (2.0) 2.2 (3.0) 3.7 (5.0)	0.4 (0.5) 0.75 (1.0) 1.5 (2.0) 2.2 (3.0) 4.0 (5.0)	0.75 (1.0) 1.5 (2.0) 2.2 (3.0) 4.0 (5.0)
C		2.2 (3.0)	5.5 (7.5) 7.5 (10.0)	5.5 (7.5) 7.5 (10.0) 11.0 (15.0)	5.5 (7.5) 7.5 (10.0) 11.0 (15.0)

Shaded areas are applicable to PowerFlex 40 only.

Flange Mount Drive

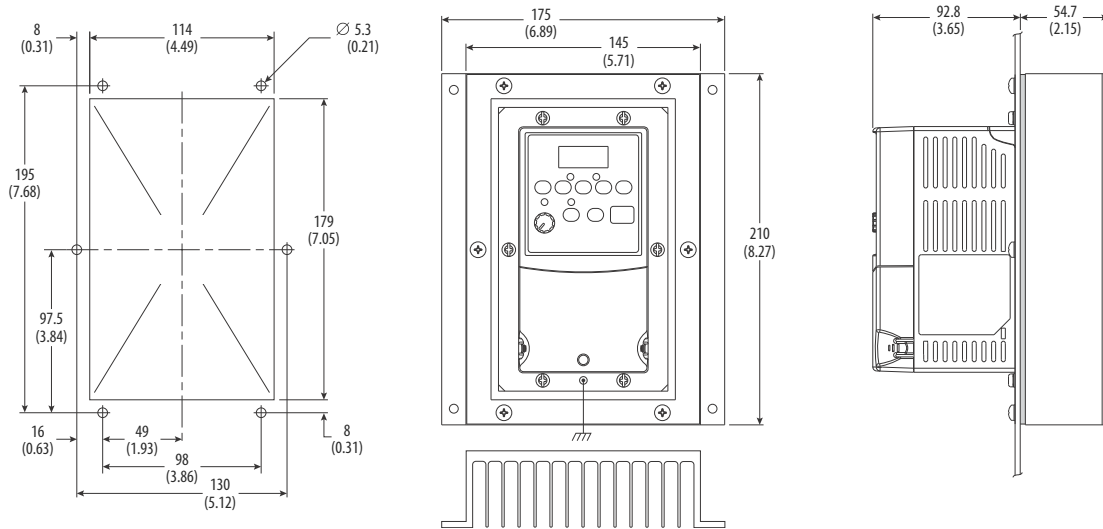

Frame A — PowerFlex 4 only

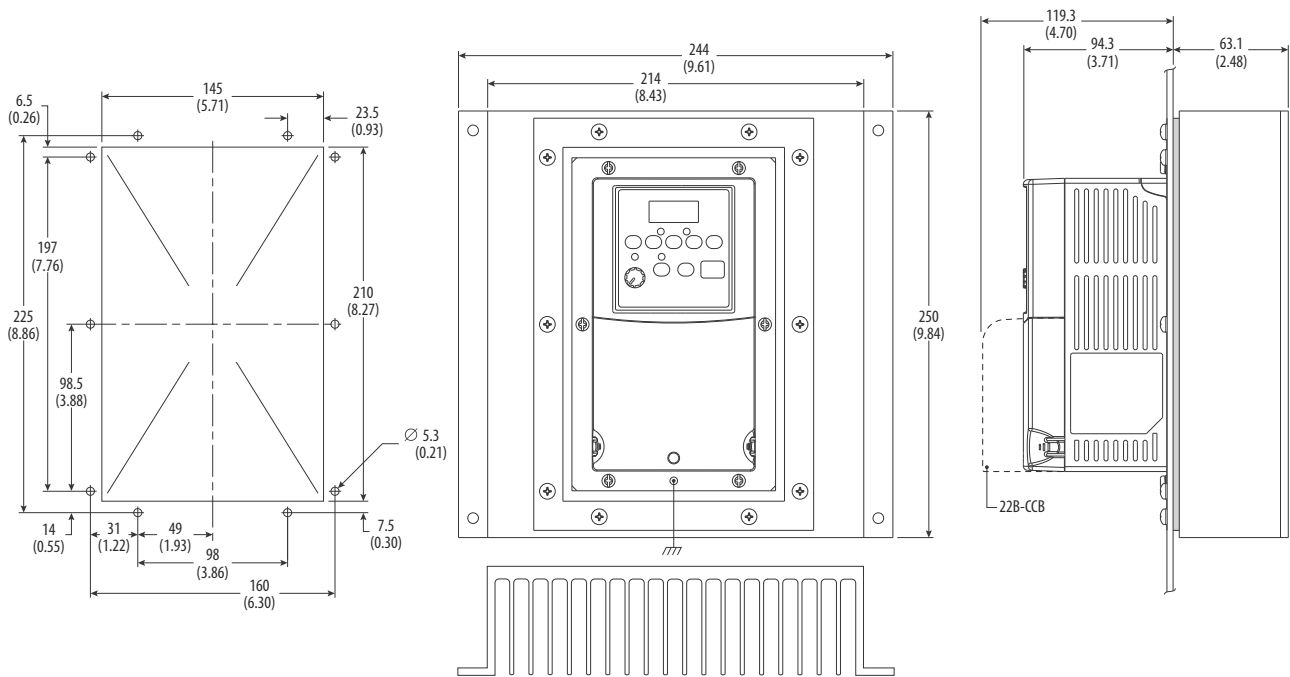

Frame B — PowerFlex 4 and PowerFlex 40

Flange Mount Drive *Continued*

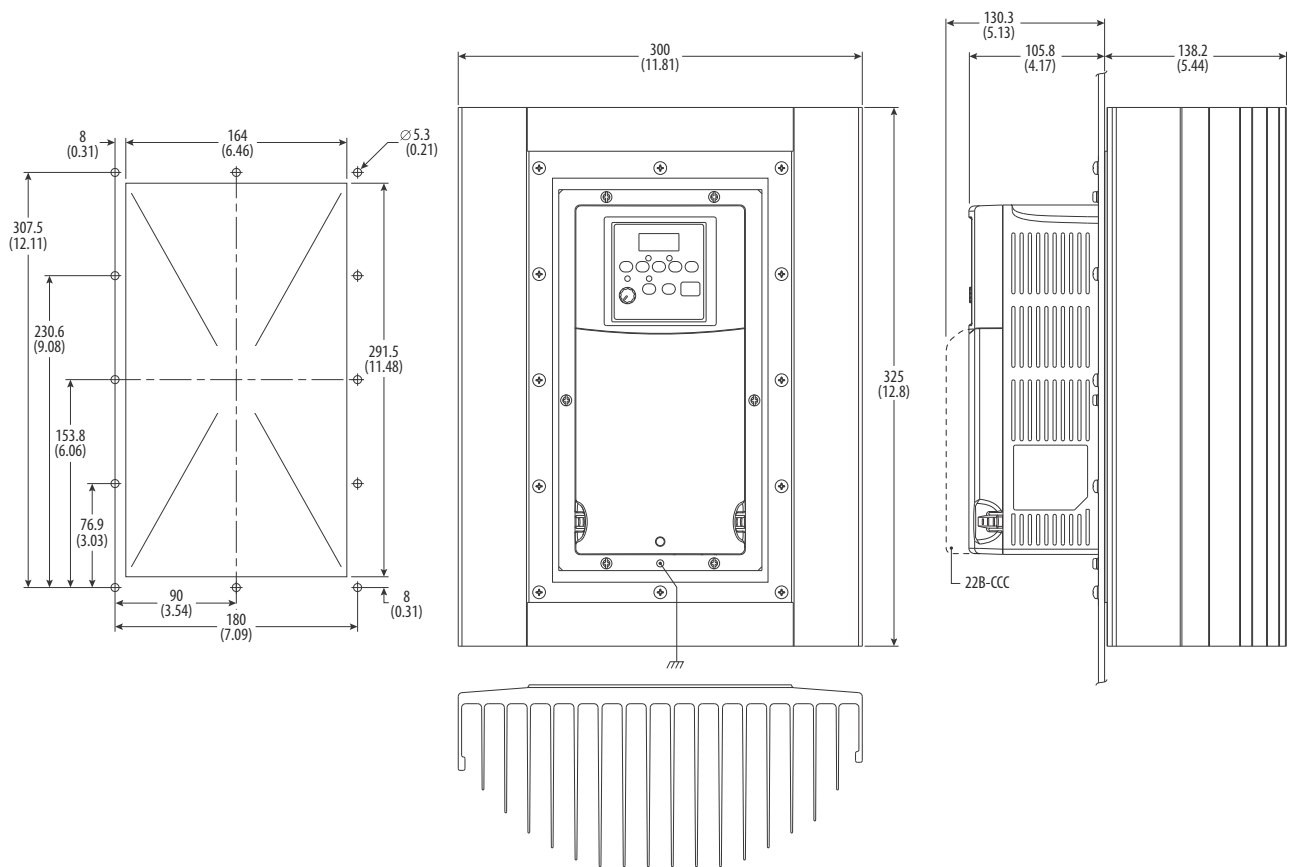

Frame C—PowerFlex 40 only

IP 66, NEMA/UL Type 4X/12

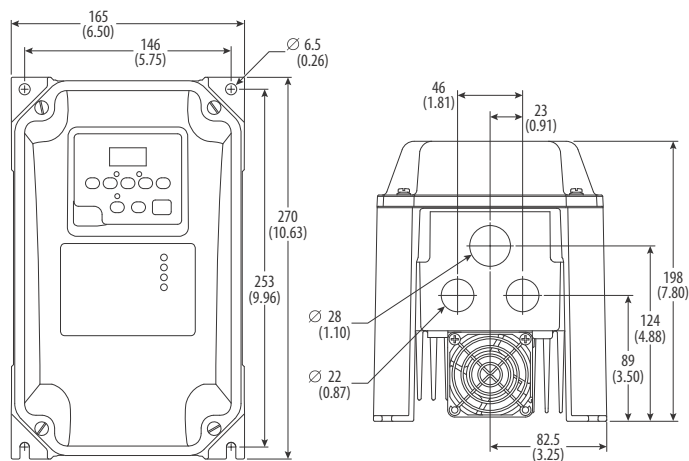

Frame B—PowerFlex 40 only

Shaded areas are applicable to PowerFlex 40 only.

IP 30, NEMA/UL Type 1 Option Kit without Communication Options

PowerFlex 4 uses Frames A and B. PowerFlex 40 uses Frames B and C.

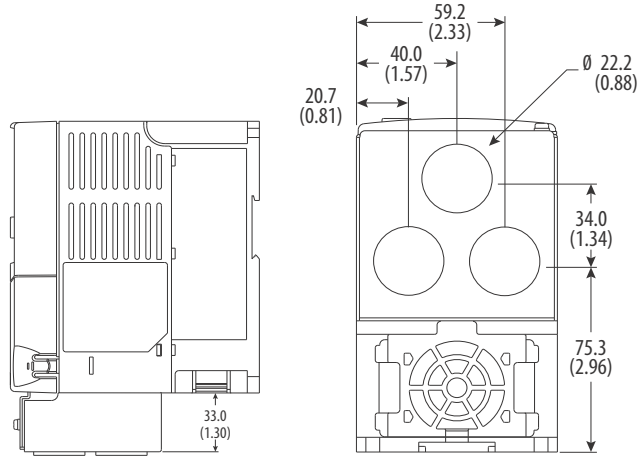

Frame A — 22-JBAA

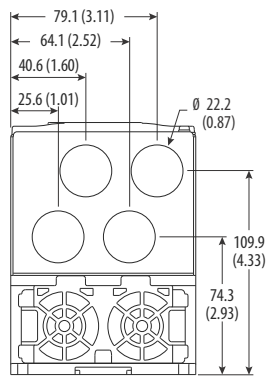
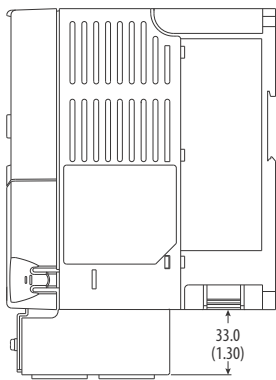

Frame B — 22-JBAB

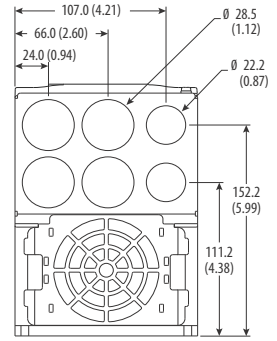
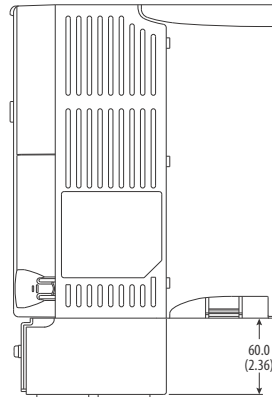

Frame C — 22-JBAC

PowerFlex 40 IP 30/NEMA 1/UL Type 1 Option Kit with Communication Option

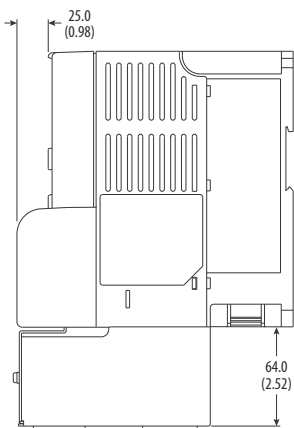

Frame B — 22-JBCB

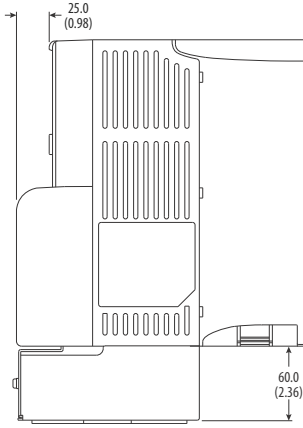
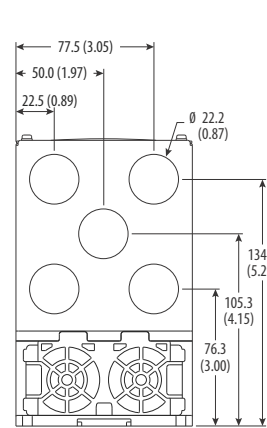

Frame C — 22-JBCC

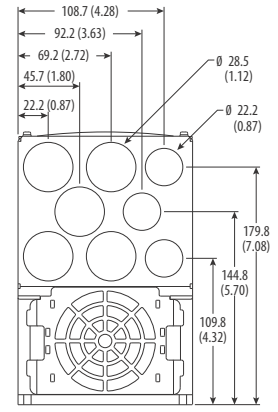

Shaded areas are applicable to PowerFlex 40 only.

Dynamic Brake Resistors

Dimensions are in millimeters and (inches)

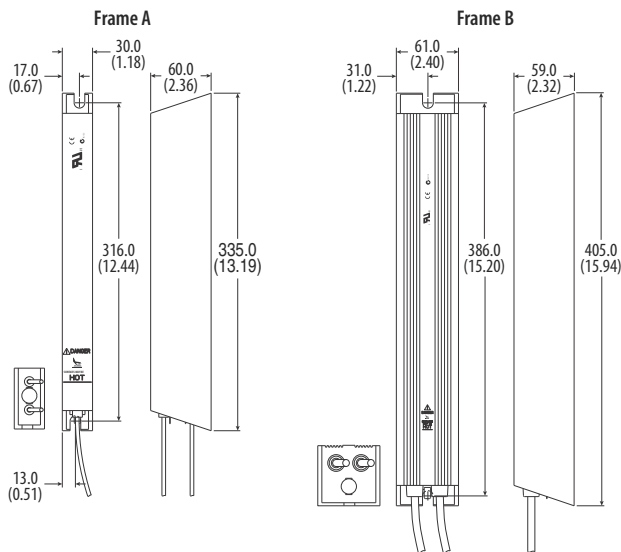

Frame	Catalog Number
A	AK-R2-091P500, AK-R2-047P500, AK-R2-360P500
B	AK-R2-030P1K2, AK-R2-120P1K2

Bulletin 1321-3R Series Line Reactors

Dimensions are in millimeters and (inches). Weights are in kilograms and (pounds).

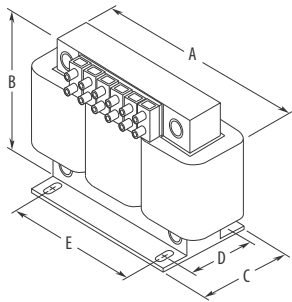

Catalog Number	A	B	C	D	E	Weight
1321-3R2-A	112 (4.40)	104 (4.10)	70 (2.75)	50 (1.98)	37 (1.44)	1.8 (4)
1321-3R2-B	112 (4.40)	104 (4.10)	70 (2.75)	50 (1.98)	37 (1.44)	1.8 (4)
1321-3R4-A	112 (4.40)	104 (4.10)	76 (3.00)	50 (1.98)	37 (1.44)	1.8 (4)
1321-3R4-B	112 (4.40)	104 (4.10)	76 (3.00)	50 (1.98)	37 (1.44)	1.8 (4)
1321-3R4-C	112 (4.40)	104 (4.10)	86 (3.38)	60 (2.35)	37 (1.44)	2.3 (5)
1321-3R8-A	152 (6.00)	127 (5.00)	76 (3.00)	53 (2.10)	51 (2.00)	3.1 (7)
1321-3R8-B	152 (6.00)	127 (5.00)	76 (3.00)	53 (2.10)	51 (2.00)	3.6 (8)
1321-3R8-C	152 (6.00)	127 (5.00)	85 (3.35)	63 (2.48)	51 (2.00)	4.9 (11)
1321-3R12-A	152 (6.00)	127 (5.00)	76 (3.00)	53 (2.10)	51 (2.00)	4.1 (9)
1321-3R12-B	152 (6.00)	127 (5.00)	76 (3.00)	53 (2.10)	51 (2.00)	4.5 (10)
1321-3R18-A	152 (6.00)	133 (5.25)	79 (3.10)	54 (2.13)	51 (2.00)	4.1 (9)
1321-3R18-B	152 (6.00)	133 (5.25)	86 (3.40)	63 (2.48)	51 (2.00)	5.4 (12)
1321-3R25-A	183 (7.20)	146 (5.76)	85 (3.35)	60 (2.35)	76 (3.00)	4.9 (11)
1321-3R35-A	193 (7.60)	146 (5.76)	91 (3.60)	66 (2.60)	76 (3.00)	6.3 (14)

EMC Line Filters

Frame A EMC Line Filters – Dimensions are in millimeters and (inches)
 Catalog Numbers: 22-RF5P7-AS, -AL; 22-RF9P5-AS, -AL; 22-RF010-AL

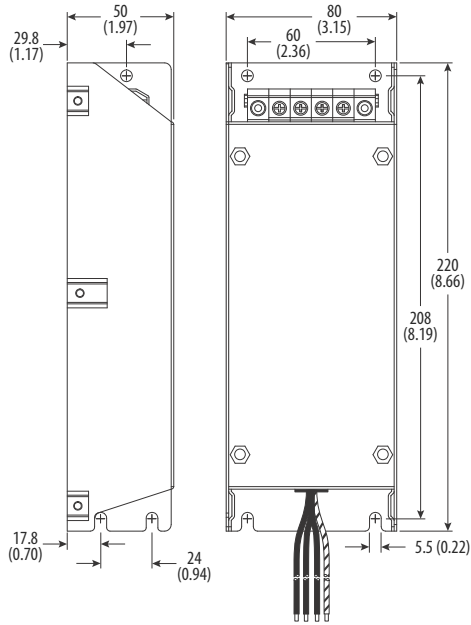

Frame B EMC Line Filters – Dimensions are in millimeters and (inches)
 Catalog Numbers: 22-RF8P0-BL, 22-RF012-BS, -BL; 22-RF018-BL;
 22-RF021-BS, -BL

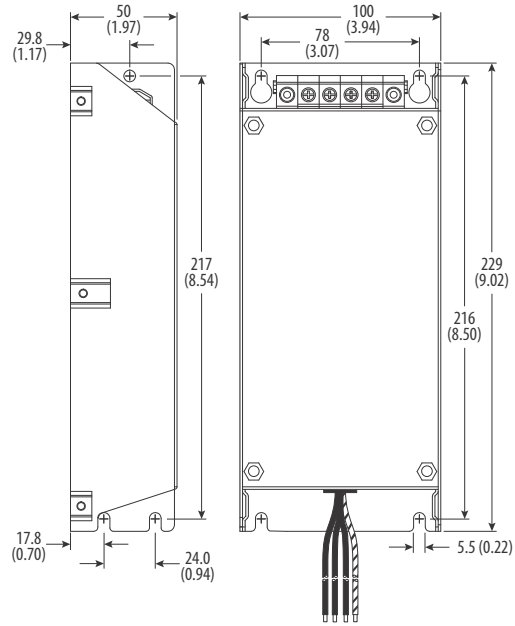

Frame C EMC Line Filters – Dimensions are in millimeters and (inches)
 Catalog Numbers: 22-RF015-CL; 22-RF018-CS, -CL; 22-RF024-CL; 22-RF025-CL; 22-RF026-CS, -CL; 22RF034-CS, -CL

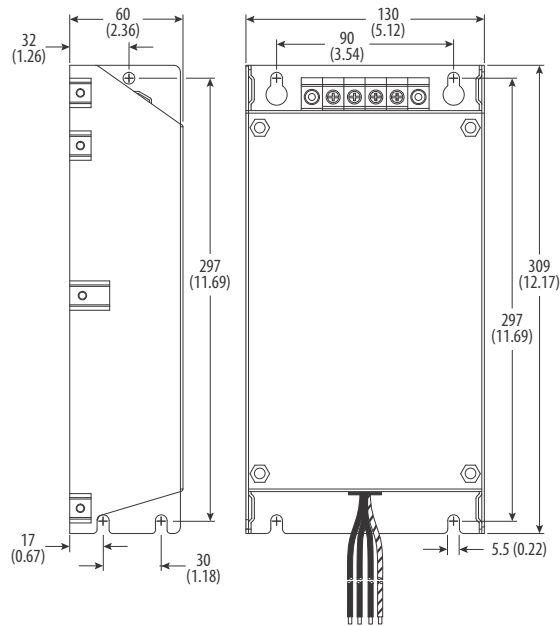

Human Interface Module (HIM) Dimensions

NEMA Type 1 Bezel – Dimensions are in millimeters and (inches)
 Catalog Number: 22-HIM-B1

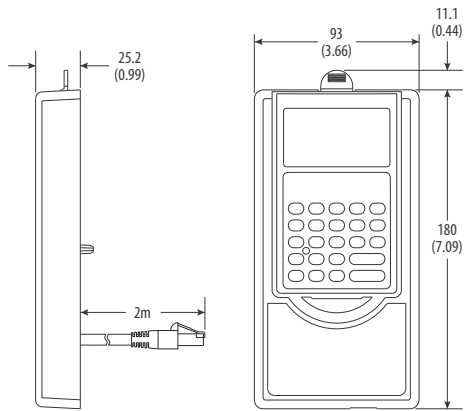

NEMA Type 4X/12 Remote (Panel Mount) HIM
 – Dimensions are in millimeters and (inches)
 Catalog Number: 22-HIM-C2S

