

Mini Circuit Breakers, Fuse Blocks, and Electronic Circuit Protection

Topic	Page
1489-M Miniature Circuit Breakers	2
1492-SP Supplementary Protectors	15
1492-D Circuit Breakers	27
188 Regional Circuit Breakers	37
1492-RCD Residual Current Devices	53
1692 Electronic Circuit Protectors	59
1492-MC Circuit Breakers	61
1492-GH/-GS Circuit Breakers	67
1492-FB Fuse Blocks	71

Summary of Changes

This publication contains new and updated information as indicated in the following table.

Topic	Page
1489-M Ambient Temperature Derating Charts	7
1492-SP Ambient Temperature Derating Charts	17
1492-MCG Ground Sensing Rated Voltage and Interrupting Capacity Circuit Breaker Catalog Numbers	61

Additional Resources

These documents contain additional information concerning related products from Rockwell Automation.

Resource	Description
Control Circuit and Load Protection Selection Guide, publication 1492-SG122	Provides product selection and technical information.
Industrial Automation Wiring and Grounding Guidelines, publication 1770-4.1	Provides general guidelines for installing a Rockwell Automation industrial system.
Product Certifications website, http://www.ab.com	Provides declarations of conformity, certificates, and other certification details.

You can view or download publications at <http://www.rockwellautomation.com/literature/>. To order paper copies of technical documentation, contact your local Allen-Bradley distributor or Rockwell Automation sales representative.



1489-M Specifications

Electrical Ratings	
Poles	1, 2, 3
Tripping characteristics	C, D
Rated current (I_n)	0.5...63 A
Rated frequency [f]	50/60 Hz
Rated insulation voltage U_i per IEC/EN 60664-1	250V AC (phase to ground) 440V AC (phase to phase)
Overvoltage category	III
Pollution degree	3

Data per UL/CSA					
Rated voltage	AC	1-pole	C Curve	0.5...40 A	277V AC
				50...63 A	240V AC
		D Curve		0.5...35 A	277V AC
				40...63 A	240V AC
	2-, 3-pole	C Curve		0.5...40 A	480Y/277V AC
				50...63 A	240V AC
		D Curve		0.5...35 A	480Y/277V AC
				40...63 A	240V AC
DC	1-pole			48V DC	
	2-pole			96V DC (2-pole in series)	

Rated interrupting capacity per UL 489	10 kA
Reference temperature for tripping characteristics	40 °C
Electrical endurance	6,000 operations (AC and DC); 1 cycle (1s - ON, 9s - OFF)

Data per IEC/EN 60947-2			
Rated operational voltage (U_e)	1-pole		230V AC
	2-, 3-pole		400 V AC
Highest supply or utilization voltage (U_{max})	AC	1-pole	253/440V AC
		2-, 3-pole	440V AC
	DC ★	1-pole	48V DC
		2-pole	96V DC
Min. operating voltage			12V AC, 12V DC
Rated ultimate short-circuit breaking capacity (I_{CU})			15 kA
Rated service short-circuit breaking capacity (I_{CS})			≤40 A: 11.25 kA >40 A: 7.5 kA
Rated impulse withstand voltage U_{imp} . (1.2/50μs)			4 kV (test voltage 6.2kV at sea level, 5kV at 2,000m)
Dielectric test voltage			2 kV (50/60Hz, 1 min.)
Reference temperature for tripping characteristics			30 °C
Electrical endurance			$I_n < 30A$:20,000 ops.(AC) $I_n \geq 30A$:10,000 ops. (AC) 1,000 ops. (DC)
1 cycle (2s - ON, 13s - OFF, $I_n \leq 32A$),			
1 cycle (2s - ON, 28s - OFF, $I_n > 32A$)			

★ Self-declared IEC DC ratings.

Mechanical Data	
Housing	Insulation group II, RAL 7035
Indicator window	red ON/green OFF
Protection degree per EN 60529	IP20, IP40 in enclosure with cover
Mechanical endurance	20,000 operations
Shock resistance per IEC/EN 60068-2-27	25 g - 2 shocks - 13 ms
Vibration resistance per IEC/EN 60068-2-6	5g - 20 cycles at 5...150...5 Hz with load 0.8 In

Environmental	
Environmental conditions (damp heat) per IEC/EN 60068-2-30	28 cycles with 55°C/90-96% and 25°C/95-100%
Ambient temperature Δ	-25...+55 °C
Storage temperature	-40...+70 °C

Installation	
Terminal	Dual terminal
Cross-section of wire ◆ – solid, stranded (front/back terminal slot)	35/35 mm ² 18...4/18...10 AWG
Cross-section of wire – flexible (front/back terminal slot)	25/10 mm ²
Multi-wire rating per UL, CSA	1 wire, 18...4 AWG 2-4 wires‡, 18...10 AWG
Cross-section of bus bars (back terminal slot)	10 mm ²

Tightening torque	IEC	2.8 N•m
	UL/CSA	AWG 18...16: 13.3 in•lb, AWG 14...10: 17.7 in•lb, AWG 8...4: 39.8 in•lb
Screwdriver	No. 2 Pozidrive	
Mounting	DIN Rail (EN 60715, 35 mm) with fast clip	
Mounting position	Any	
Supply	Optional	

Approximate Dimensions and Weight	
Pole dimensions (H x D x W)	111 x 69 x 17.5 mm (4.37 x 2.72 x .69")
Pole weight	125 g (4.4 oz.)

Combination with Auxiliary Elements	
Auxiliary contact	Yes
Signal contact	Yes
Shunt trip	Yes

◆ 35 mm self-declared, not included in IEC/EN approval.

Δ Refer to the ambient temperature derating tables.

‡ Wires must be of like size and stranding. Up to two wires per terminal slot.

Power Loss Due to Current

Rated Current [A]	Power Loss Per Pole [W]		Rated Current [A]	Power Loss Per Pole [W]
0.5	1.4		15	2.4
1	1.4		16	2.5
1.6	1.8		20	2.5
2	1.8		25	3.2
3	1.6		30	3.5
4	1.8		32	3.7
5	1.9		35	4.1
6	2.0		40	4.5
7	1.1		50	4.5
8	1.5		60	4.9
10	2.1		63	5.4
13	2.3		—	—

Zero-stack Derating

The installation of several miniature circuit breaker side by side with rated current on all poles requires a correction factor to the rated current (not required if spacers are used).

No. of Adjacent Devices	Factor
1	1
2,3	0.9
4,5	0.8
≥ 6	0.75

Approximate Dimensions

Note: Dimensions are shown in millimeters (inches). Dimensions are not intended for manufacturing purposes.

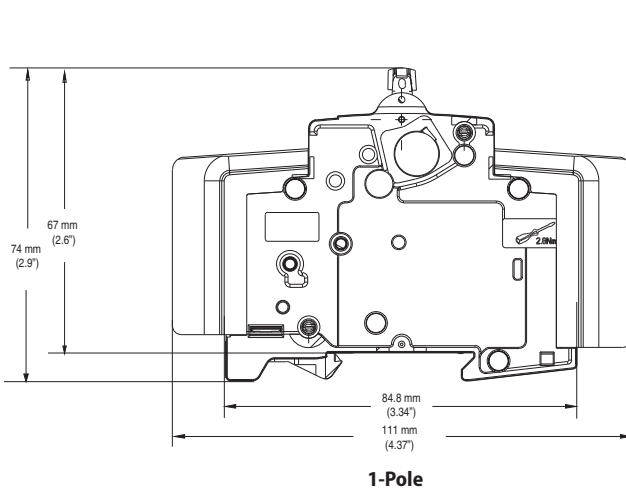

1-Pole

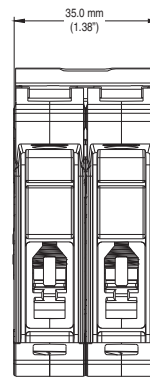
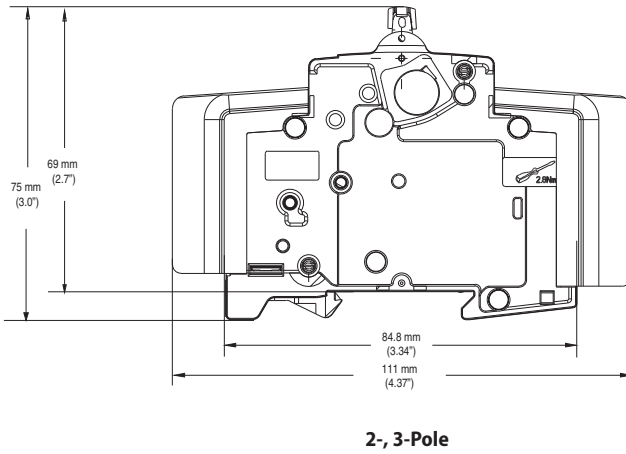

2-Pole

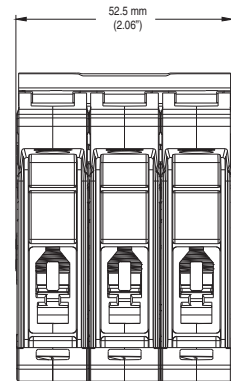

3-Pole

Application Information

Circuit Voltage

The Bulletin 1489-M circuit breakers are rated by voltage class. Applications should not exceed the listed voltage and current range.

Circuit Frequency

The Bulletin 1489-M circuit breakers may be applied to frequencies of 50 Hz and 60 Hz without derating. For applications above 60 Hz, contact Rockwell Automation with specific application information for the derating of the circuit breakers.

Available Short Circuit Current

The Bulletin 1489-M circuit breakers should only be applied in those applications in which the available short-circuit (or fault) current is less than or equal to 10 kA (US/Canada) and 15 kA (IEC).

Tripping Characteristics

The trip curve characteristics are shown on the following pages. The trip bands shown for each breaker represent current tripping limits for a circuit breaker and are within the limits established by UL.

The standard tripping characteristic for Bulletin 1489-M is Type C. Type C has a magnetic trip activated at 5-10 times the rated current of the circuit breaker. The reference temperature for the thermal tripping characteristics is 30 °C. The Type C characteristic will suit most applications.

In rare occurrences when the Type C characteristic does not fully meet the application, Type D magnetic trip characteristic is available, allowing for transients approximately twice as high as the standard Type C.

For a specific current at 30 °C, a circuit breaker will open ("clear the circuit") automatically at some total time that will be within the minimum and maximum time shown on the curves. For example, a one-pole, 15 A, Bulletin 1489-M circuit breaker trips in not less than 1 s and not more than 200 s on a 30 A current. Because the UL standard defines this time spread, users should not specify exact tripping time. The lower current portion of the curves (upper left) depicts the time to trip due to thermal action and reflect overload protection of the wire and connect load. The higher current portion of the curves (lower right) depicts the trip due to magnetic action of the circuit breaker and reflects protection due to short circuit level currents.

Application Considerations

The following is a discussion of application considerations related to North American applications. When applying product to IEC regional requirements, follow IEC practices and guidelines.

The selection of a specific ampere rating for a specific application is dependent on the type of load and duty cycle and is governed by the National Electrical Code (Canadian Electrical Code) and UL/CSA. In general, the codes require that overcurrent protection is at the current supply and at points where wire sizes are reduced. In addition, the codes state that conductors be protected according to their current carrying capacity. There are specific situations that require application consideration, such as motor circuit, and guidelines for the selection for transformer protection.

The Bulletin 1489-M circuit breakers are "non-100% rated" as defined by UL 489, para 7.1.4.2. As such, the circuit breaker's rating should be loaded to no more than 80% if used with continuous loads.

Line and load may be reversed. The Bulletin 1489-M circuit breaker may be bottom fed.

Branch Circuits

Bulletin 1489-M circuit breakers may be used to protect branch circuits. A branch circuit is the wiring portion of a system extending beyond the final overcurrent device protecting the circuit. Guidelines established in NEC, CEC, UL, and CSA should be used to determine the specific device. For example:

Motor Branch Circuit

Bulletin 1489-M circuit breakers are not horsepower rated because they are able to safely interrupt currents far in excess of the locked rotor value for a selected motor. This ability is recognized in the codes and standards and is also established by the UL and CSA tests described in UL 489 and CSA C22.2 No. 5 standards.

The size of a Bulletin 1489-M circuit breaker should be determined following the guidelines for an Inverse Time Circuit Breaker.

References: NEC 430.51 and UL 489. Also see CEC and appropriate Canadian Standards.

Transformer Protection

Bulletin 1489-M circuit breakers may be used for transformer protection following the guidelines established.

References: NEC 450 and UL 489. Also see CEC and appropriate Canadian Standards.

Heater Load, Lighting, and Other Load Protection

Bulletin 1489-M circuit breakers may be used for protection of heater loads, lighting loads, and other loads following the guidelines established.

References: NEC Article 31 and UL 508A. Also see CEC and appropriate Canadian Standards.

SWD Rating

The Bulletin 1489-M breakers (0.5 ... 20 A) are rated as Switch Duty (SWD) and as such may be applied to switch fluorescent lighting loads up to their current and voltage maximum.

Coordinated Overcurrent Protection

Where an orderly shutdown is required to minimize the hazards to personnel and equipment, a system of coordination based upon the faulted or overloaded circuit is isolated by selective operation of only the overcurrent protective device closest to the overcurrent condition. The user should select devices that meet this requirement.

References: NEC 240.12. Also see CEC.

HACR Rating

Bulletin 1489-M Circuit Breakers are rated as Heating, Air Conditioning and Refrigeration circuit breakers as defined by UL 489, paragraph 6.7 and may be used in this type of application.

Current Limiting

Bulletin 1489-M Circuit Breakers are rated as current limiting circuit breakers as defined by UL 489, paragraph 8.6.

The Bulletin 1489-M line features the ability to achieve short circuit interruptions far more effectively than conventional breakers. In conventional circuit breakers, the short circuit interruption time required is approximately one or two half cycles of an AC sine wave. When the contacts open, the resulting arc continues to burn until the current level passes through zero. The arc may re-ignite because of the insufficient width of the contact gap. The current that flows until the arc is extinguished produces a heating effect proportional to the I^2t value (let-through-energy) of the fault current.

The Bulletin 1489-M device is designed to substantially reduce the amount of let-through-current and the resulting let-through-energy that can damage protected components. The Bulletin 1489-M has the ability to interrupt short circuit current within the first half cycle of the fault. Limiting let-through current and energy will protect against the harmful effects of overcurrent and is focused primarily on avoiding excessive heat and mechanical damage.

Both of these factors are proportional to the square of the current. Thermal energy is proportional to the square of the RMS value and magnetic forces are proportional to the square of the peak value. The most effective way to provide protection is to substantially limit let-through-energy. This provides the following advantages:

- Far less damage at the location of the short circuit.
- Fast electric separation of a faulty unit from the system, especially power supplies connected in parallel that are switched off when the voltage of the power bus drops below a certain level.
- Far less wear on the miniature circuit breaker itself. This means more safe interruptions.
- Better protection of all components in the short circuit path.
- Far wider range of selective action when used with an upstream protective device. (No nuisance shut downs from feeder line interruptions, causing a blackout in all connected branches.)

Ambient Temperature Derating

The Bulletin 1489-M circuit breakers are rated in RMS amperes at a 40 °C (104 °F) ambient temperature per UL 489/CSA C22.2 No. 5. This temperature is used as the ambient temperature external to an industrial enclosure. If a circuit breaker is applied in a temperature that exceeds the 40 °C (104 °F) ambient rating, then the circuit breaker should be derated using the table below. For IEC 60947-2 standard, the products carry an ambient rating of 30 °C. Follow standard IEC application considerations for temperature rating in different ambient temperatures.

Note: Application below 0° C is for non-condensing atmosphere. Care should be taken for applications below 0 °C. These devices are not certified to operate correctly in the presence of ice.

1489-M
UL Derating
Reference Temp: 40°C

RU200	Ambient Temperature (°C)											
In(A)	-40	-30	-20	-10	0	10	20	30	40	50	60	70
0.5	0.65	0.63	0.61	0.59	0.57	0.56	0.54	0.52	0.5	0.48	0.46	0.44
1	1.30	1.26	1.22	1.19	1.15	1.11	1.07	1.04	1	0.96	0.93	0.89
1.6	2.06	2.01	1.96	1.90	1.84	1.78	1.72	1.66	1.6	1.54	1.48	1.42
2	2.60	2.52	2.44	2.37	2.30	2.22	2.15	2.07	2	1.93	1.85	1.78
3	3.89	3.78	3.67	3.56	3.44	3.33	3.22	3.11	3	2.89	2.78	2.67
4	5.19	5.04	4.89	4.74	4.59	4.44	4.30	4.15	4	3.85	3.70	3.56
5	6.50	6.31	6.13	5.94	5.75	5.56	5.38	5.19	5	4.81	4.63	4.44
6	7.77	7.55	7.33	7.11	6.89	6.67	6.44	6.22	6	5.78	5.56	5.33
7	9.10	8.84	8.58	8.31	8.05	7.79	7.53	7.26	7	6.74	6.48	6.21
8	10.36	10.07	9.78	9.48	9.18	8.89	8.59	8.30	8	7.70	7.41	7.11
10	13.00	12.60	12.20	11.90	11.50	11.10	10.70	10.40	10	9.60	9.30	8.90
13	16.90	16.40	15.90	15.40	14.90	14.40	14.00	13.50	13	12.50	12.00	11.60
15	19.50	18.94	18.38	17.81	17.25	16.69	16.13	15.56	15	14.44	13.88	13.31
16	20.60	20.10	19.60	19.00	18.40	17.80	17.20	16.60	16	15.40	14.80	14.20
20	26.00	25.20	24.40	23.70	23.00	22.20	21.50	20.70	20	19.30	18.50	17.80
25	32.40	31.50	30.60	29.60	28.70	27.80	26.90	25.90	25	24.10	23.20	22.20
30	39.00	37.88	36.75	35.63	34.50	33.38	32.25	31.13	30	28.88	27.75	26.63
32	41.50	40.30	39.10	37.90	36.70	35.60	34.40	33.20	32	30.80	29.60	28.40
35	45.50	44.19	42.88	41.56	40.25	38.94	37.63	36.31	35	33.69	32.38	31.06
40	51.90	50.40	48.90	47.40	45.90	44.40	43.00	41.50	40	38.50	37.00	35.60
50	64.90	63.00	61.10	59.30	57.40	55.60	53.70	51.90	50	48.20	46.30	44.50
60	78.00	75.75	73.50	71.25	69.00	66.75	64.50	62.25	60	57.75	55.50	53.25
63	81.60	79.30	77.00	74.70	72.30	70.00	67.70	65.30	63	60.70	58.30	56.00

1489-M
IEC Derating
Reference Temp: 30°C

RU200	Ambient Temperature (°C)											
In(A)	-40	-30	-20	-10	0	10	20	30	40	50	60	70
0.5	0.63	0.61	0.59	0.57	0.56	0.54	0.52	0.5	0.48	0.46	0.44	0.43
1	1.26	1.22	1.19	1.15	1.11	1.07	1.04	1	0.96	0.93	0.89	0.85
1.6	2.01	1.96	1.90	1.84	1.78	1.72	1.66	1.6	1.54	1.48	1.42	1.36
2	2.52	2.44	2.37	2.30	2.22	2.15	2.07	2	1.93	1.85	1.78	1.70
3	3.78	3.67	3.56	3.44	3.33	3.22	3.11	3	2.89	2.78	2.67	2.56
4	5.04	4.89	4.74	4.59	4.44	4.30	4.15	4	3.85	3.70	3.56	3.41
5	6.31	6.13	5.94	5.75	5.56	5.38	5.19	5	4.81	4.63	4.44	4.25
6	7.55	7.33	7.11	6.89	6.67	6.44	6.22	6	5.78	5.56	5.33	5.11
7	8.84	8.58	8.31	8.05	7.79	7.53	7.26	7	6.74	6.48	6.21	5.95
8	10.07	9.78	9.48	9.18	8.89	8.59	8.30	8	7.70	7.41	7.11	6.82
10	12.60	12.20	11.90	11.50	11.10	10.70	10.40	10	9.60	9.30	8.90	8.50
13	16.40	15.90	15.40	14.90	14.40	14.00	13.50	13	12.50	12.00	11.60	11.10
15	18.94	18.38	17.81	17.25	16.69	16.13	15.56	15	14.44	13.88	13.31	12.75
16	20.10	19.60	19.00	18.40	17.80	17.20	16.60	16	15.40	14.80	14.20	13.60
20	25.20	24.40	23.70	23.00	22.20	21.50	20.70	20	19.30	18.50	17.80	17.00
25	31.50	30.60	29.60	28.70	27.80	26.90	25.90	25	24.10	23.20	22.20	21.30
30	37.88	36.75	35.63	34.50	33.38	32.25	31.13	30	28.88	27.75	26.63	25.50
32	40.30	39.10	37.90	36.70	35.60	34.40	33.20	32	30.80	29.60	28.40	27.30
35	44.19	42.88	41.56	40.25	38.94	37.63	36.31	35	33.69	32.38	31.06	29.75
40	50.40	48.90	47.40	45.90	44.40	43.00	41.50	40	38.50	37.00	35.60	34.10
50	63.00	61.10	59.30	57.40	55.60	53.70	51.90	50	48.20	46.30	44.50	42.60
60	75.75	73.50	71.25	69.00	66.75	64.50	62.25	60	57.75	55.50	53.25	51.00
63	79.30	77.00	74.70	72.30	70.00	67.70	65.30	63	60.70	58.30	56.00	53.70

Tripping Characteristics

C Curve

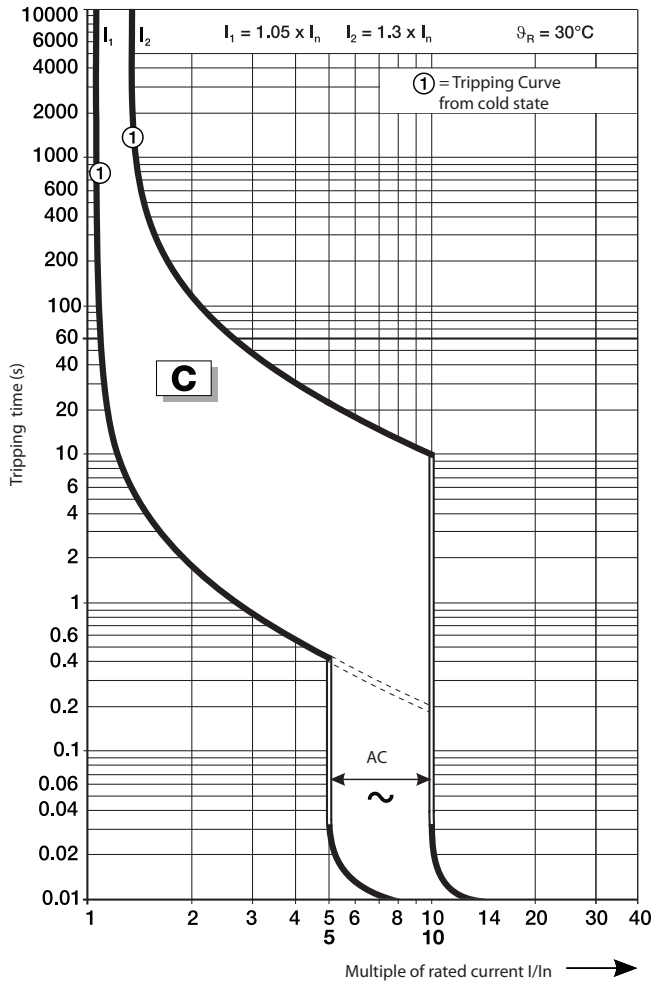

D Curve

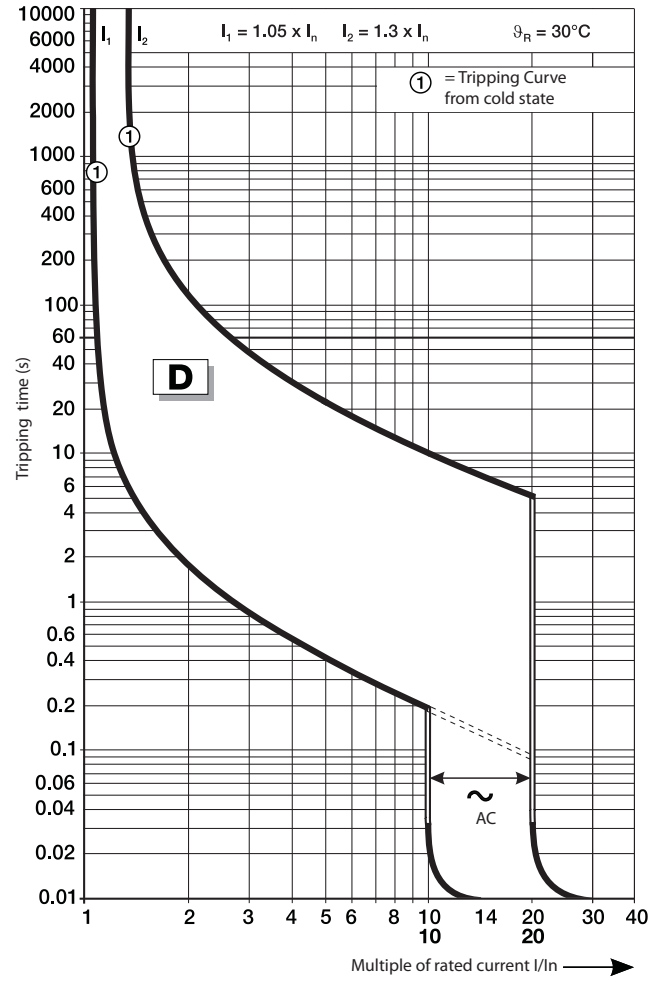

Accessory Approximate Dimensions

Note: Dimensions are shown in millimeters (inches). Dimensions are not intended for manufacturing purposes.

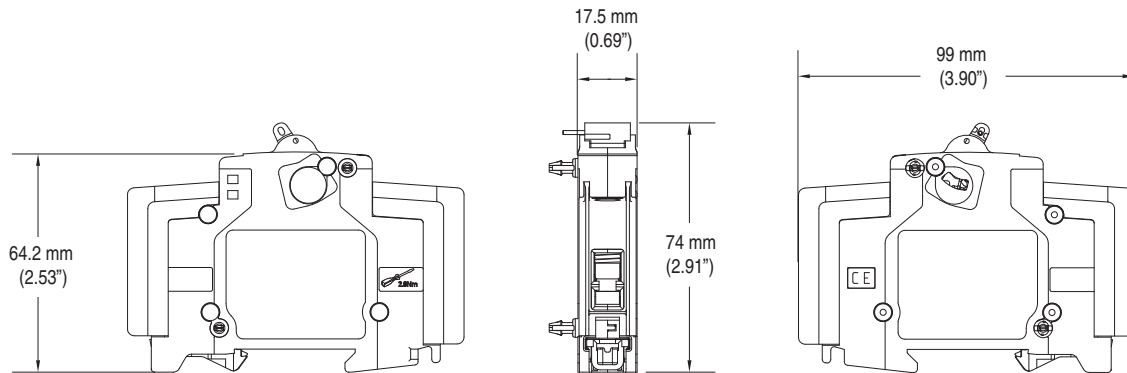

1489-AMST1 and 1489-AMST2

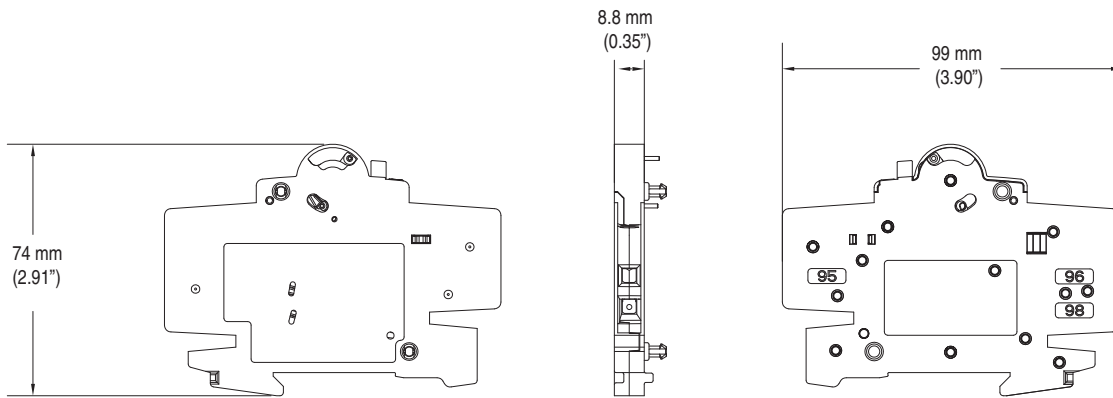

1489-AMRS3

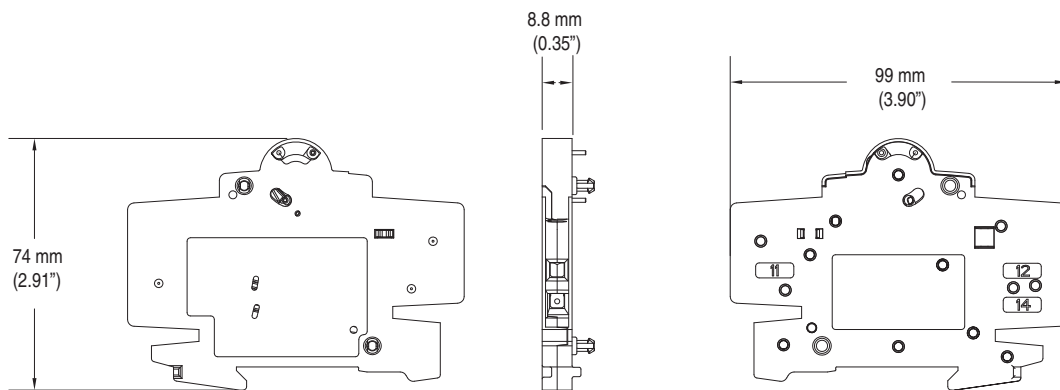

1489-AMRA3

Bus Bar Approximate Dimensions

Note: Dimensions are shown in millimeters (inches). Dimensions are not intended for manufacturing purposes.

1-Phase Bus Bars

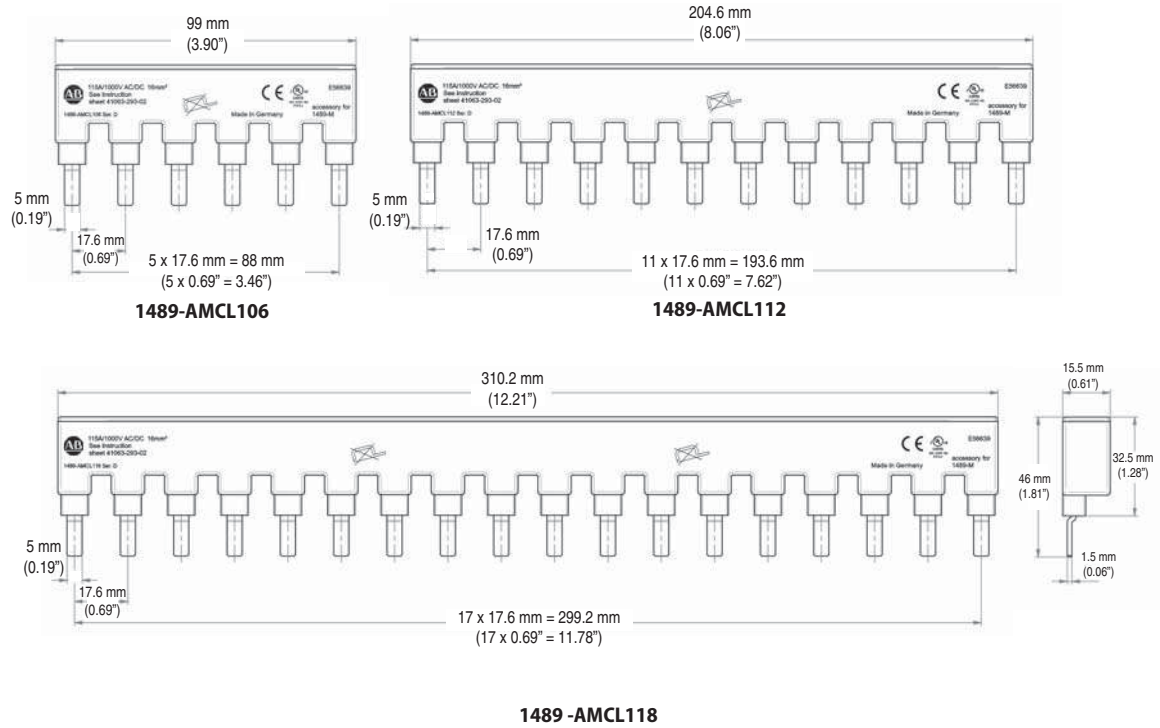

Bus Bar Approximate Dimensions

Note: Dimensions are shown in millimeters (inches). Dimensions are not intended for manufacturing purposes.

2-Phase Bus Bars

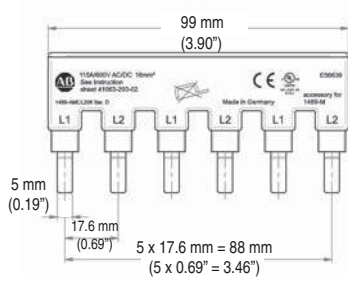

1489-AMCL206

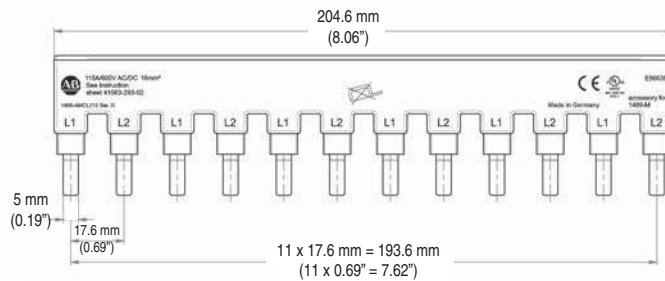

1489-AMCL212

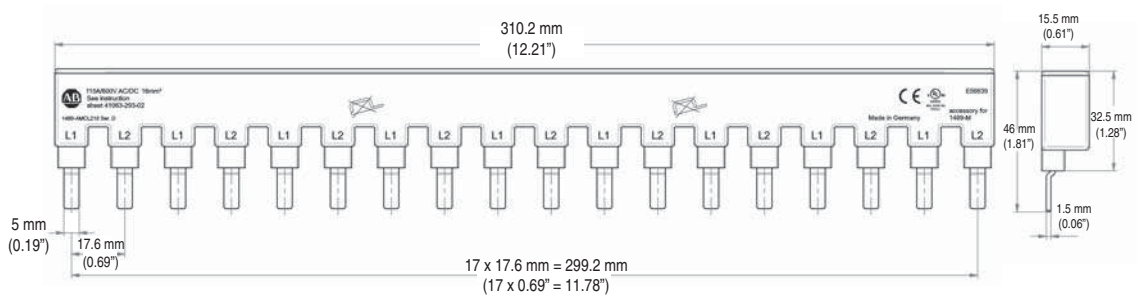

1489-AMCL218

Bus Bar Approximate Dimensions

Note: Dimensions are shown in millimeters (inches). Dimensions are not intended for manufacturing purposes.

3-Phase Bus Bars

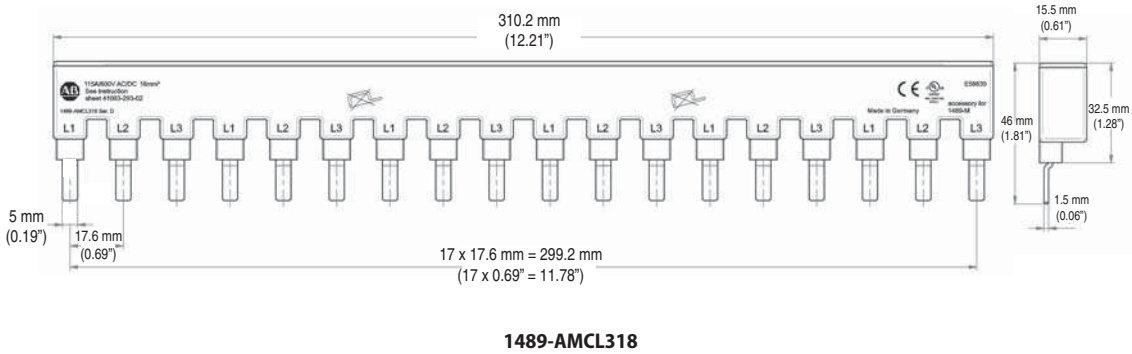
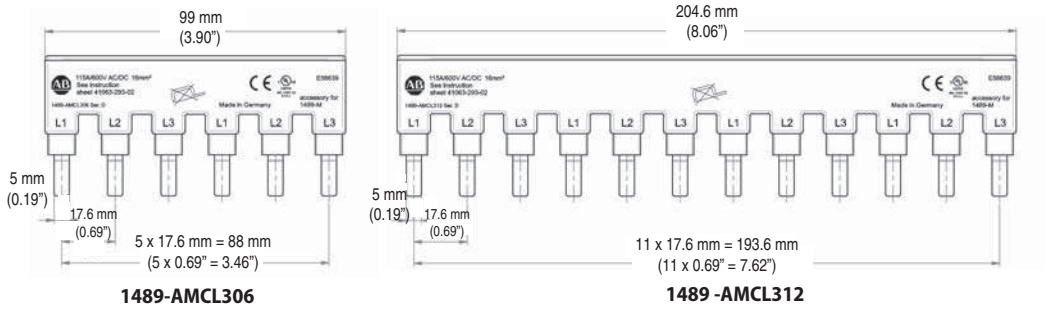

Bus Bar Accessory Approximate Dimensions

Note: Dimensions are shown in millimeters (inches). Dimensions are not intended for manufacturing purposes.

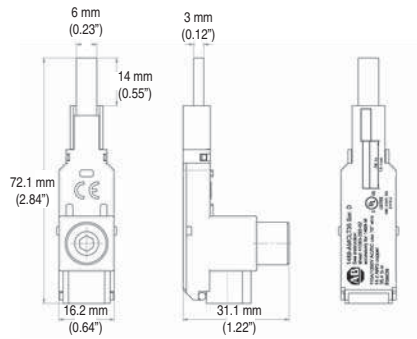

1489-AMCLT35

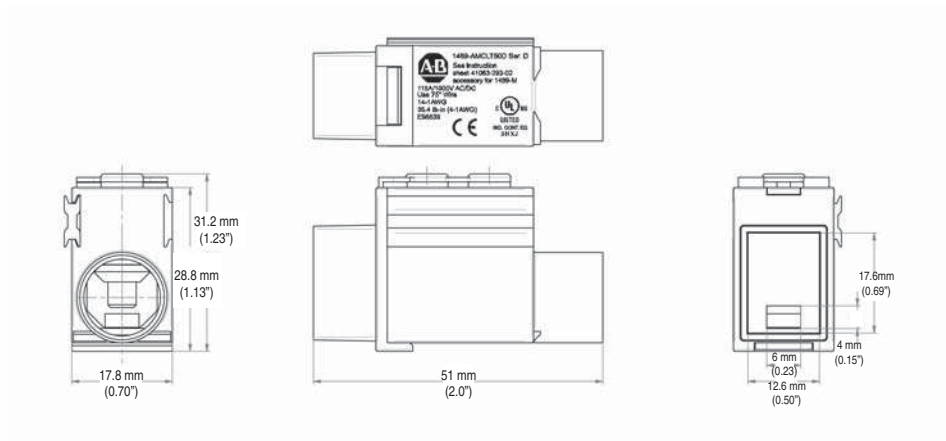

1489-AMCLT50D

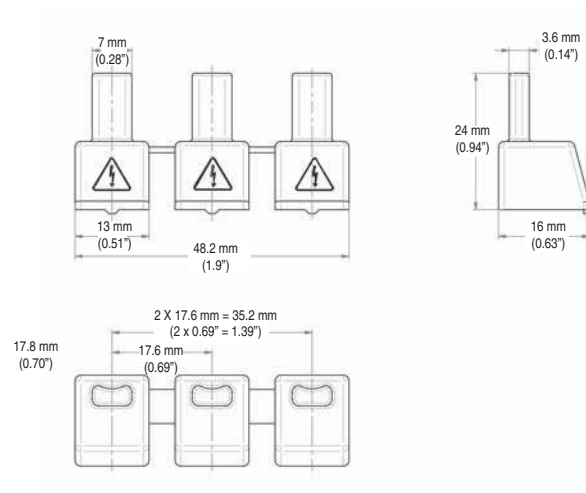

1489-AMCLPS

Notes

1492-SP Specifications

Electrical Ratings			
Poles	1, 2, 3, 1+N, 3+N		
Tripping characteristics	B, C, D		
Rated current (I_n)	0.5...63 A		
Rated frequency (f)	50/60 Hz		
Rated insulation voltage U_i per IEC/EN 60664-1	250 V AC (phase to ground), 440V AC (phase to phase)		
Overvoltage category	III		
Pollution degree	3		
Data per UL/CSA			
Rated voltage	1-pole	AC	277V AC
		DC	48V DC
	2-pole	AC	480Y/277V AC
		DC	96V DC
	3-pole	AC	480Y/277V AC
	Rated interrupting capacity per UL 1077		≤ 32 A: 10 kA (AC); > 32 A: 5 kA (AC); 0.5...63 A: 10 kA (DC)
Application		Supplementary protector for general use; application codes: TC1: [1P] OLO 277V AC, [2P;3P] OLO 480Y/277V AC; SC: 10 kA (0.5...32 A), 5 kA (35...63 A), U2 480Y/277V AC; FW3	
Reference temperature for tripping characteristics		40 °C	
Electrical endurance		6,000 ops (AC), 6,000 ops. (DC) 1 cycle (1s - ON, 9s - OFF)	
Data per IEC/EN 60947-2			
Rated operational voltage (U_e)	1-pole, 1+N		230V AC
	2-pole, 3-pole, 3+N		400V AC
Highest supply or utilization voltage (U_{max})	AC	1-pole, 1+N	253V AC
		2-pole, 3-pole, 3+N	440V AC
	DC★	1-pole	48V DC
		2-pole	96V DC
Min. operating voltage		12V AC, 12V DC	
Rated ultimate short-circuit breaking capacity (I_{cu})		15 kA	
Rated service short-circuit breaking capacity (I_{cs})		≤ 40 A: 11.25 kA > 40 A: 7.5 kA	
Rated impulse withstand voltage U_{imp} . (1.2/50 μ s)		4 kV (test voltage 6.2kV at sea level, 5kV at 2,000m)	
Dielectric test voltage		2 kV (50/60Hz, 1 min.)	
Reference temperature for tripping characteristics		30 °C	
Electrical endurance		$I_n < 30$ A: 20,000 ops (AC) $I_n \geq 30$ A: 10,000 ops. (AC) 1,000 ops. (DC)	
1 cycle (2s - ON, 13s - OFF, $I_n \leq 32$ A), 1 cycle (2s - ON, 28s - OFF, $I_n > 32$ A)			

★ IEC DC ratings self-declared.

♣ 2-pole/3-pole single pole load: TC2.

Mechanical Data		
Housing	Insulation group II, RAL 7035	
Indicator window	red ON/green OFF	
Protection degree per EN 60529	IP20, IP40 in enclosure with cover	
Mechanical endurance	20,000 operations	
Shock resistance per IEC/EN 60068-2-27	25 g - 2 shocks - 13 ms	
Vibration resistance per IEC/EN 60068-2-6	5g - 20 cycles at 5...150...5 Hz with load 0.8In	
Environmental		
Environmental conditions (damp heat) per IEC/EN 60068-2-30	28 cycles with 55°C/90-96% and 25°C/95-100%	
Ambient temperature Δ	-25...+55 °C	
Storage temperature	-40...+70 °C	
Installation		
Terminal	Dual terminal	
Cross-section of wire \blacklozenge – solid, stranded (front/back terminal slot)	35/35 mm ² 18...4/18...10 AWG	
Cross-section of wire – flexible (front/back terminal slot)	25/10 mm ²	
Multi-wire rating per UL, CSA	1 wire, 18...4 AWG 2-4 wires \ddagger , 18...10 AWG	
Cross-section of bus bars (back terminal slot)	10 mm ²	
Tightening torque	IEC	2.8 N•m
	UL/CSA	AWG 18...16: 13.3 in•lb. AWG 14...10: 17.7 in•lb. AWG 8...4: 39.8 in•lb.
Screwdriver	No. 2 Pozidrive	
Mounting	DIN rail (EN 60715, 35mm) with fast clip	
Mounting position	Any	
Supply	Optional	
Approximate Dimensions and Weight		
Pole dimension (H x D x W)	88 x 69 x 17.5 mm	
Pole weight	115 g (4.1 oz.)	
Combination with Auxiliary Elements		
Auxiliary contact	Yes	
Signal contact	Yes	
Shunt trip	Yes	

♠ 35mm² self-declared, not included in IEC/EN approval. Δ Refer to the ambient temperature derating tables. \ddagger Wires must be of like size and stranding. Up to two wires per terminal slot.

Power Loss Due to Current

Rated Current [A]	Power Loss Per Pole [W]	Rated Current [A]	Power Loss Per Pole [W]
0.5	1.4	13	2.3
1	1.4	15	2.4
2	1.8	16	2.5
3	1.6	20	2.5
4	1.8	25	3.2
5	1.9	30	3.5
6	2.0	32	3.7
7	1.1	40	4.5
8	1.5	50	4.5
10	2.1	63	5.4

Zero-stack Derating

The installation of several miniature circuit breaker side by side with rated current on all poles requires a correction factor to the rated current (not required if spacers are used).

No. of Adjacent Devices	Factor
1	1
2,3	0.9
4,5	0.8
≥ 6	0.75

Approximate Dimensions

Note: Dimensions are shown in millimeters (inches). Dimensions are not intended for manufacturing purposes.

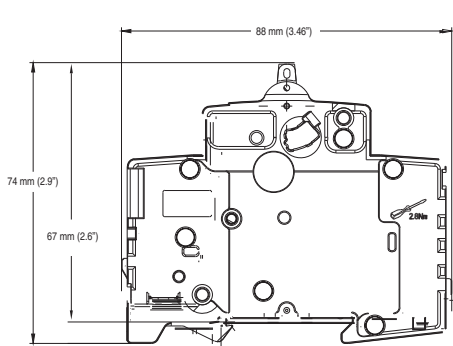

1-Pole

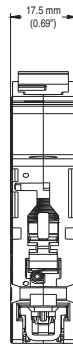

1-Pole

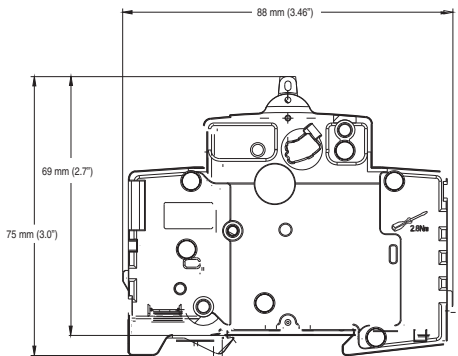

1 Pole + N, 2-, 3-, 3 Pole + N

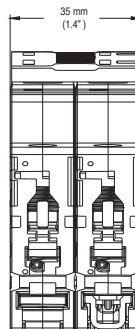

1 Pole + N, 2-Pole

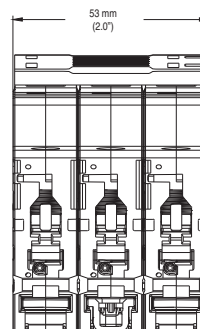

3-Pole

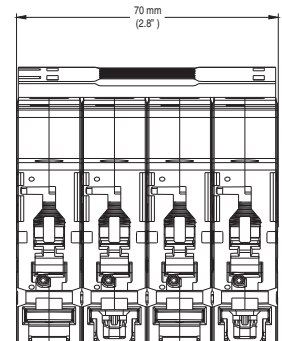

3-Pole + N

Ambient Temperature Derating

Note: Application below 0° C is for non-condensing atmosphere. Care should be taken for applications below 0 °C. These devices are not certified to operate correctly in the presence of ice.

1492-SP

UL Derating

Reference Temp: 40°C

RP200	Ambient Temperature (°C)											
In(A)	-40	-30	-20	-10	0	10	20	30	40	50	60	70
0.5	0.65	0.63	0.61	0.59	0.57	0.56	0.54	0.52	0.5	0.48	0.46	0.44
1	1.30	1.26	1.22	1.19	1.15	1.11	1.07	1.04	1	0.96	0.93	0.89
2	2.60	2.52	2.44	2.37	2.30	2.22	2.15	2.07	2	1.93	1.85	1.78
3	3.89	3.78	3.67	3.56	3.44	3.33	3.22	3.11	3	2.89	2.78	2.67
4	5.19	5.04	4.89	4.74	4.59	4.44	4.30	4.15	4	3.85	3.70	3.56
5	6.50	6.31	6.13	5.94	5.75	5.56	5.38	5.19	5	4.81	4.63	4.44
6	7.77	7.55	7.33	7.11	6.89	6.67	6.44	6.22	6	5.78	5.56	5.33
7	9.10	8.84	8.58	8.31	8.05	7.79	7.53	7.26	7	6.74	6.48	6.21
8	10.36	10.07	9.78	9.48	9.18	8.89	8.59	8.30	8	7.70	7.41	7.11
10	13.00	12.60	12.20	11.90	11.50	11.10	10.70	10.40	10	9.60	9.30	8.90
13	16.90	16.40	15.90	15.40	14.90	14.40	14.00	13.50	13	12.50	12.00	11.60
15	19.50	18.94	18.38	17.81	17.25	16.69	16.13	15.56	15	14.44	13.88	13.31
16	20.60	20.10	19.60	19.00	18.40	17.80	17.20	16.60	16	15.40	14.80	14.20
20	26.00	25.20	24.40	23.70	23.00	22.20	21.50	20.70	20	19.30	18.50	17.80
25	32.40	31.50	30.60	29.60	28.70	27.80	26.90	25.90	25	24.10	23.20	22.20
30	39.00	37.88	36.75	35.63	34.50	33.38	32.25	31.13	30	28.88	27.75	26.63
32	41.50	40.30	39.10	37.90	36.70	35.60	34.40	33.20	32	30.80	29.60	28.40
40	51.90	50.40	48.90	47.40	45.90	44.40	43.00	41.50	40	38.50	37.00	35.60
50	64.90	63.00	61.10	59.30	57.40	55.60	53.70	51.90	50	48.20	46.30	44.50
63	81.60	79.30	77.00	74.70	72.30	70.00	67.70	65.30	63	60.70	58.30	56.00

1492-SP

IEC Derating

Reference Temp: 30°C

RP200	Ambient Temperature (°C)											
In(A)	-40	-30	-20	-10	0	10	20	30	40	50	60	70
0.5	0.63	0.61	0.59	0.57	0.56	0.54	0.52	0.5	0.48	0.46	0.44	0.43
1	1.26	1.22	1.19	1.15	1.11	1.07	1.04	1	0.96	0.93	0.89	0.85
2	2.52	2.44	2.37	2.30	2.22	2.15	2.07	2	1.93	1.85	1.78	1.70
3	3.78	3.67	3.56	3.44	3.33	3.22	3.11	3	2.89	2.78	2.67	2.56
4	5.04	4.89	4.74	4.59	4.44	4.30	4.15	4	3.85	3.70	3.56	3.41
5	6.31	6.13	5.94	5.75	5.56	5.38	5.19	5	4.81	4.63	4.44	4.25
6	7.55	7.33	7.11	6.89	6.67	6.44	6.22	6	5.78	5.56	5.33	5.11
7	8.84	8.58	8.31	8.05	7.79	7.53	7.26	7	6.74	6.48	6.21	5.95
8	10.07	9.78	9.48	9.18	8.89	8.59	8.30	8	7.70	7.41	7.11	6.82
10	12.60	12.20	11.90	11.50	11.10	10.70	10.40	10	9.60	9.30	8.90	8.50
13	16.40	15.90	15.40	14.90	14.40	14.00	13.50	13	12.50	12.00	11.60	11.10
15	18.94	18.38	17.81	17.25	16.69	16.13	15.56	15	14.44	13.88	13.31	12.75
16	20.10	19.60	19.00	18.40	17.80	17.20	16.60	16	15.40	14.80	14.20	13.60
20	25.20	24.40	23.70	23.00	22.20	21.50	20.70	20	19.30	18.50	17.80	17.00
25	31.50	30.60	29.60	28.70	27.80	26.90	25.90	25	24.10	23.20	22.20	21.30
30	37.88	36.75	35.63	34.50	33.38	32.25	31.13	30	28.88	27.75	26.63	25.50
32	40.30	39.10	37.90	36.70	35.60	34.40	33.20	32	30.80	29.60	28.40	27.30
40	50.40	48.90	47.40	45.90	44.40	43.00	41.50	40	38.50	37.00	35.60	34.10
50	63.00	61.10	59.30	57.40	55.60	53.70	51.90	50	48.20	46.30	44.50	42.60
63	79.30	77.00	74.70	72.30	70.00	67.70	65.30	63	60.70	58.30	56.00	53.70

Tripping Characteristics

B Curve

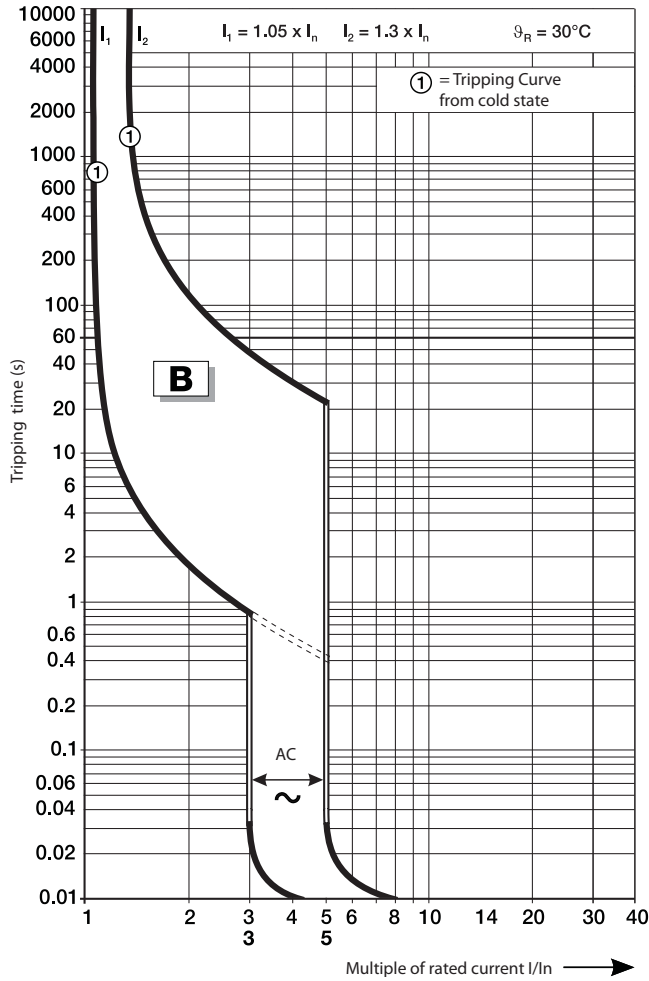

B and C Curve - 230/400V AC Let-through Energy

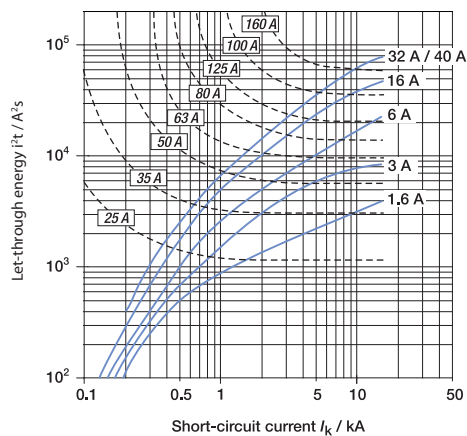
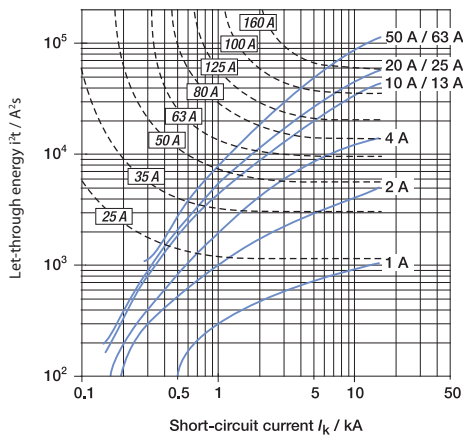

Tripping Characteristics

C Curve

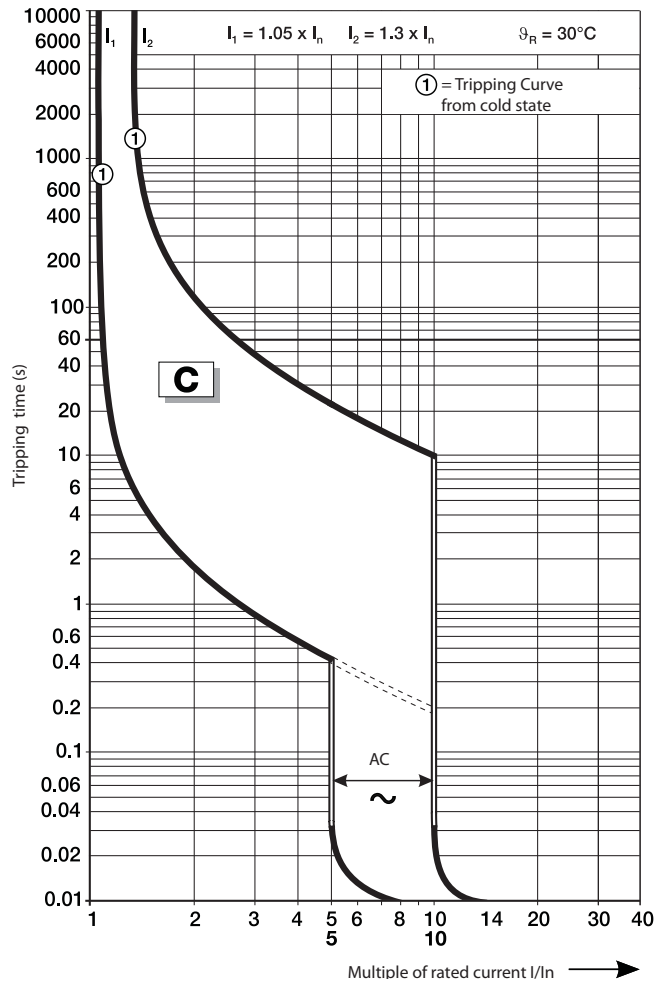

B and C Curve - 230/400V AC Let-through Energy

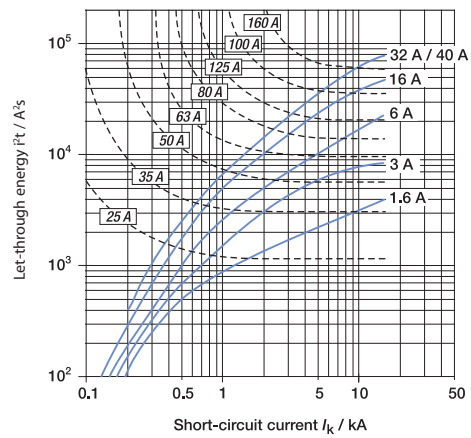
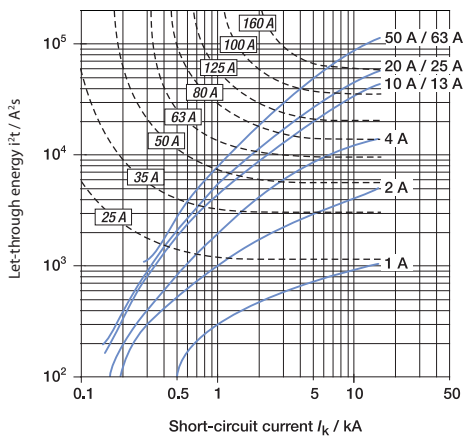

Tripping Characteristics

D Curve

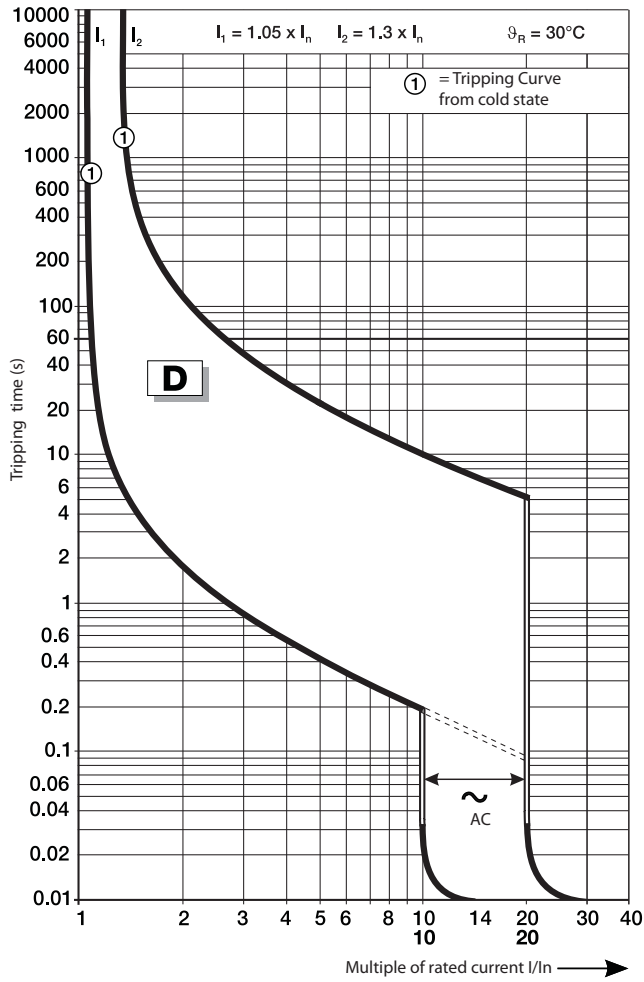

D Curve - 230/400V AC Let-through Energy

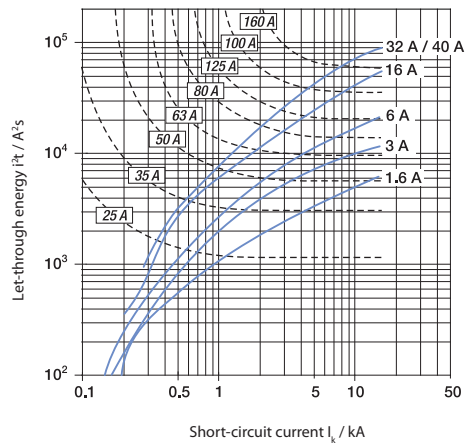
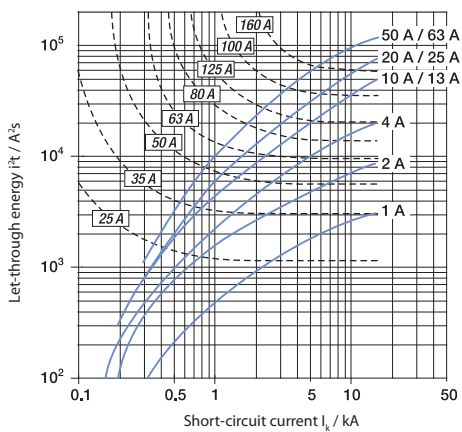

Accessory Approximate Dimensions

Note: Dimensions are shown in millimeters (inches). Dimensions are not intended for manufacturing purposes.

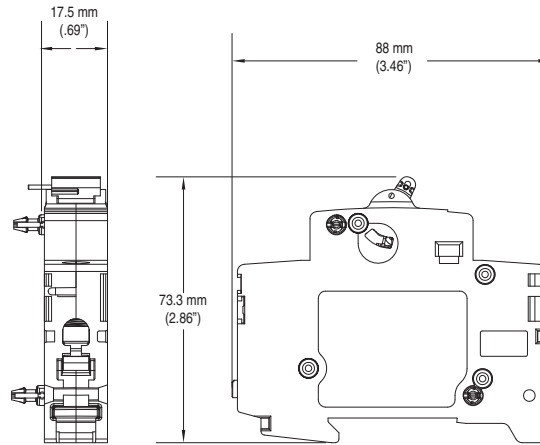

189-AST1 and 189-AST2

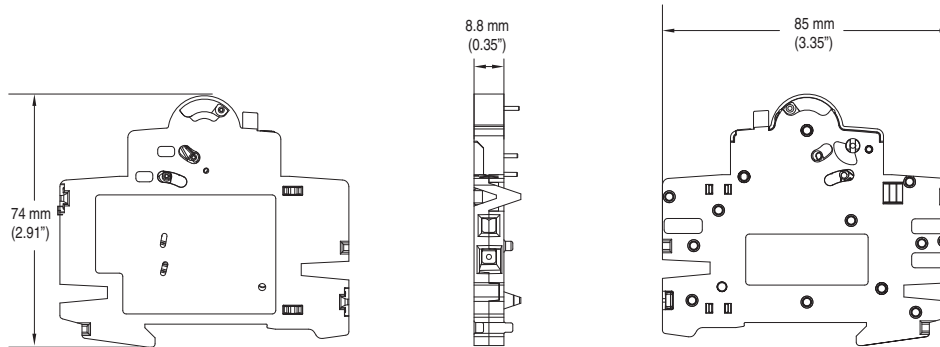

189-ASCR3

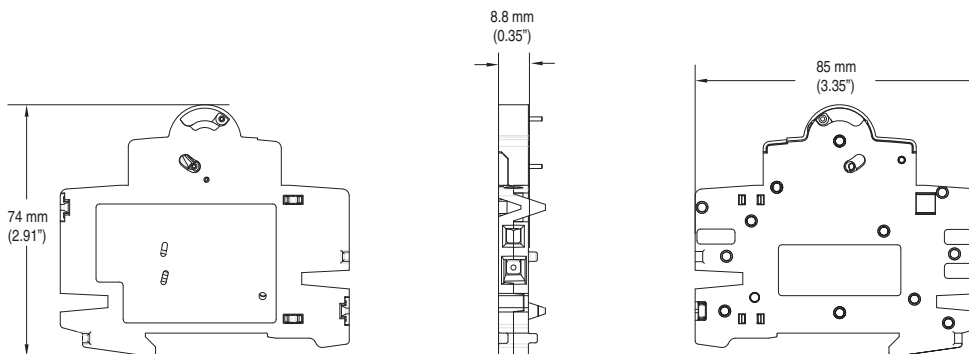

189-AR3

Accessory Approximate Dimensions

Note: Dimensions are shown in millimeters (inches). Dimensions are not intended for manufacturing purposes.

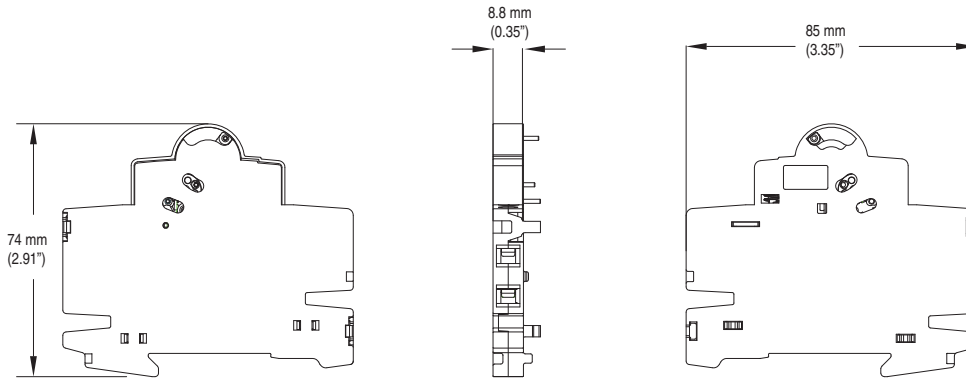

189-AR11, 189-AR02, 189-AR20

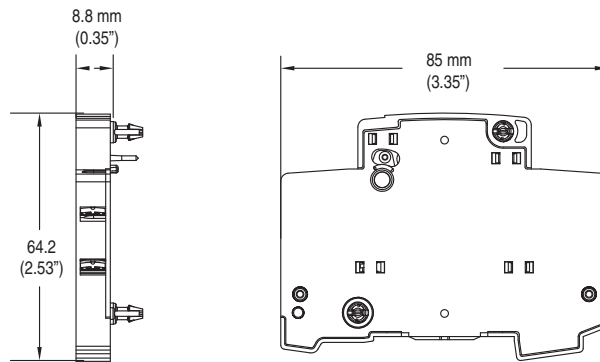

189-AL11, 189-AL02, and 189-AL20

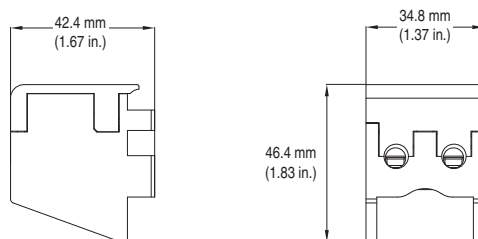

189-AB01 and 189-AB10

Bus Bar Approximate Dimensions

Note: Dimensions are shown in millimeters (inches). Dimensions are not intended for manufacturing purposes.

1-Phase Bus Bars

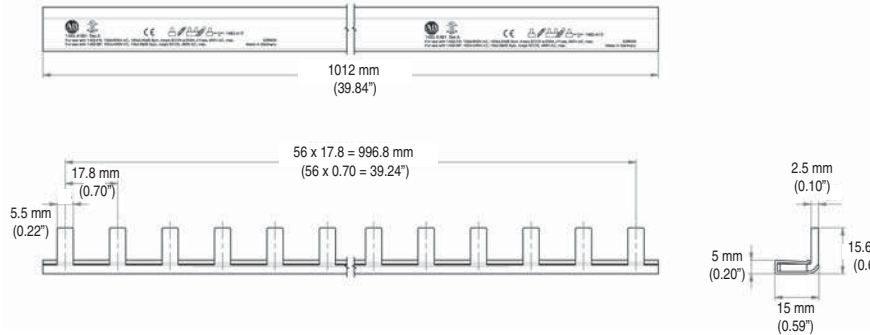

1492-A1B1

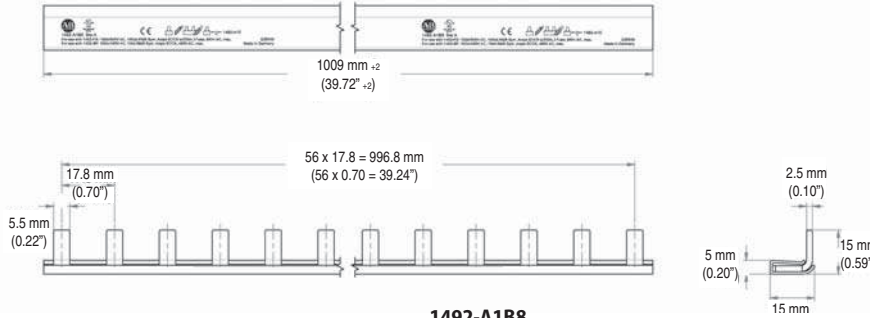

1492-A1B8

1-Phase Bus Bars, with Auxiliary Contact

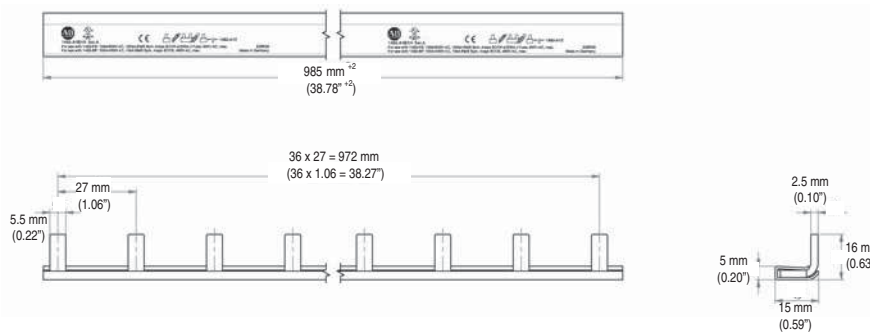

1492-A1B1H

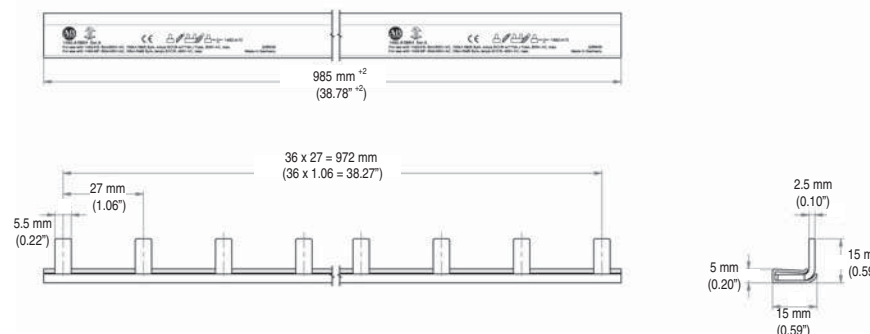

1492-A1B8H

Bus Bar Approximate Dimensions

Note: Dimensions are shown in millimeters (inches). Dimensions are not intended for manufacturing purposes.

2-Phase Bus Bars

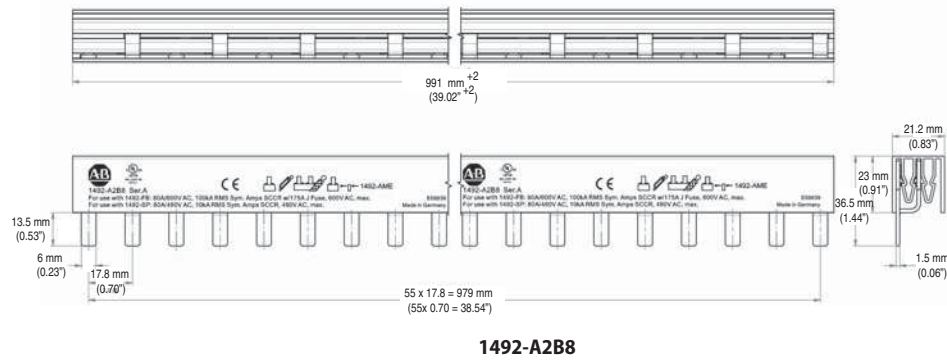
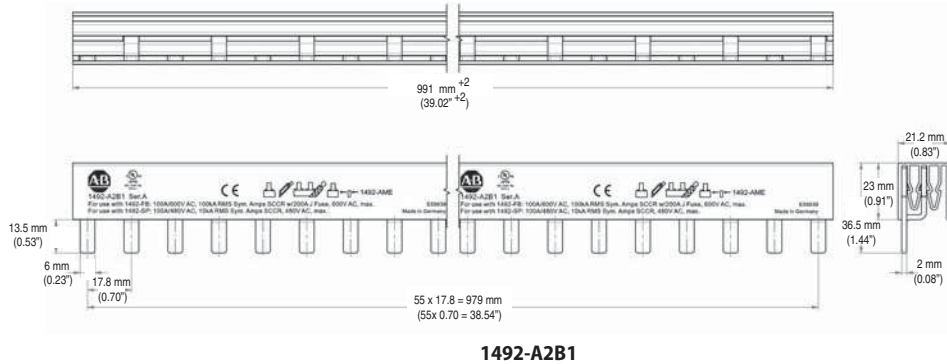

2-Phase Bus Bars, with Auxiliary Contact

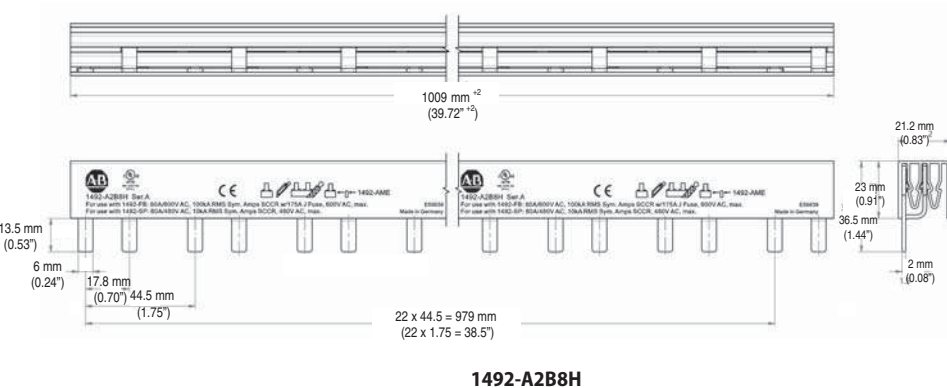
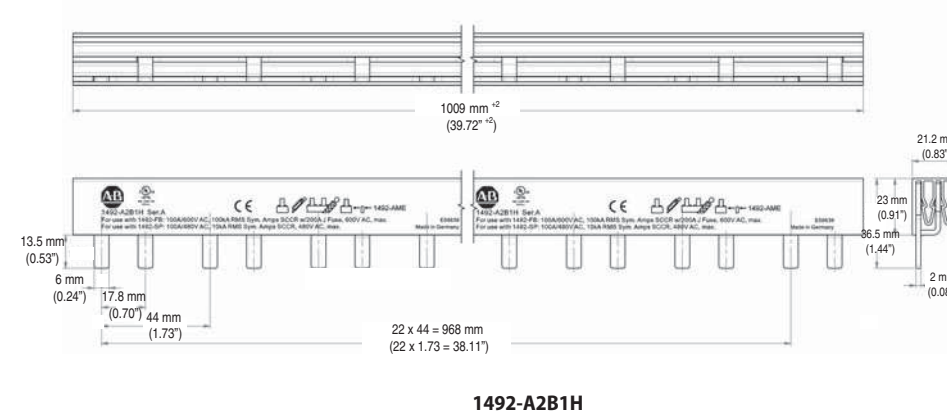

Bus Bar Approximate Dimensions

Note: Dimensions are shown in millimeters. Dimensions are not intended for manufacturing purposes.

3-Phase Bus Bars

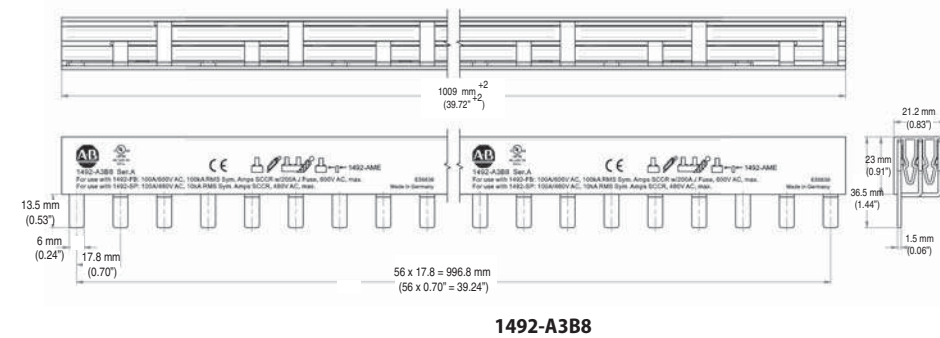
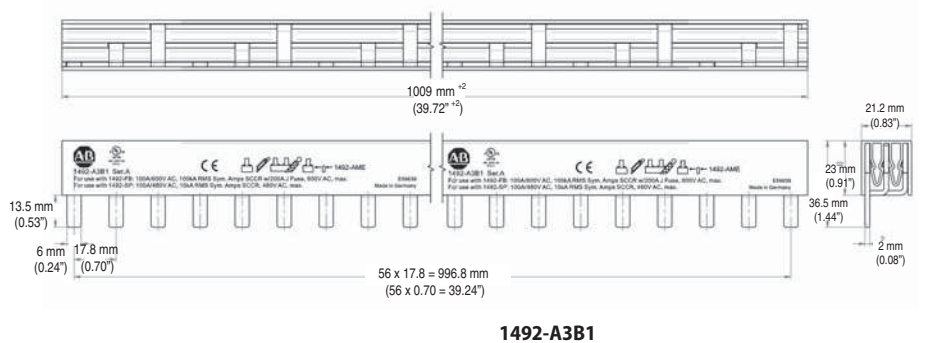

3-Phase Bus Bars, with Auxiliary Contact

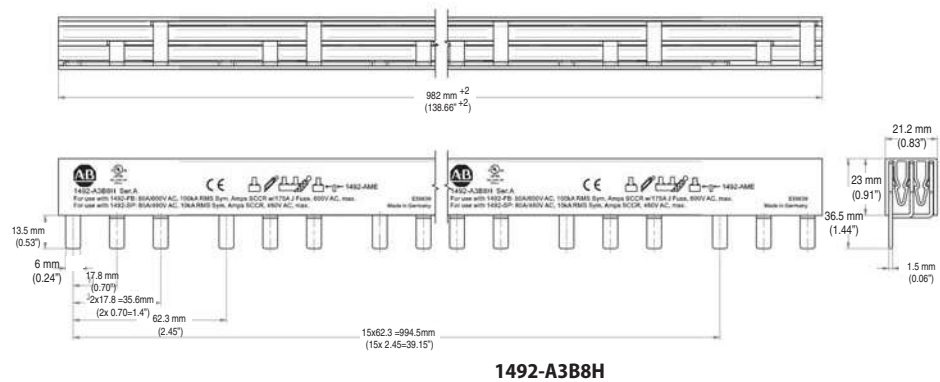
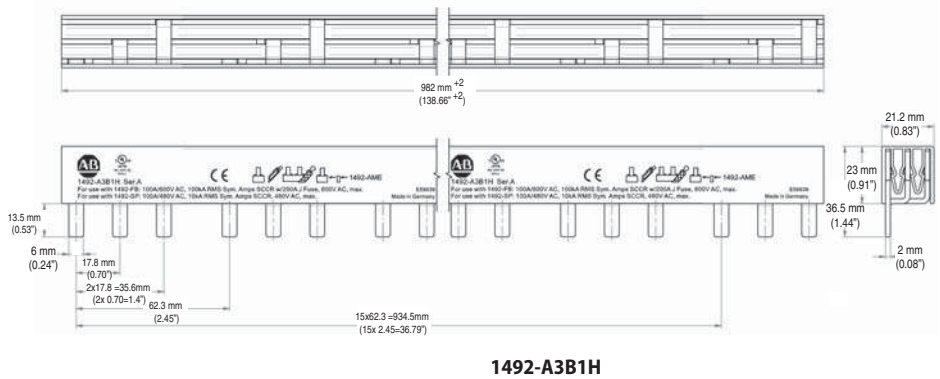

Bus Bar Accessory Approximate Dimensions

Note: Dimensions are shown in millimeters. Dimensions are not intended for manufacturing purposes.

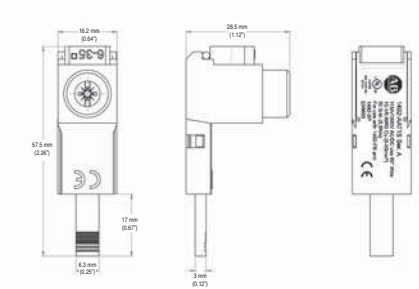

1492-AAT1S

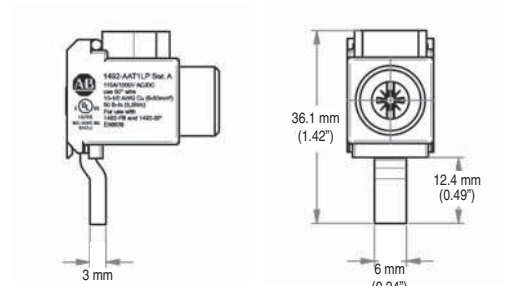
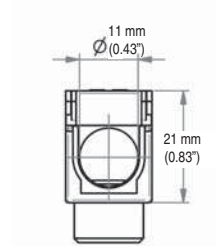

1492-AAT1LP

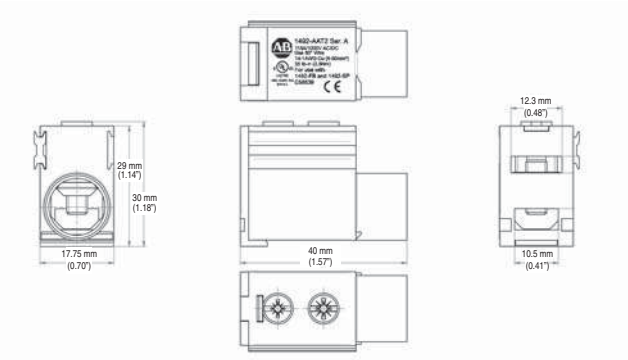

1492-AAT2

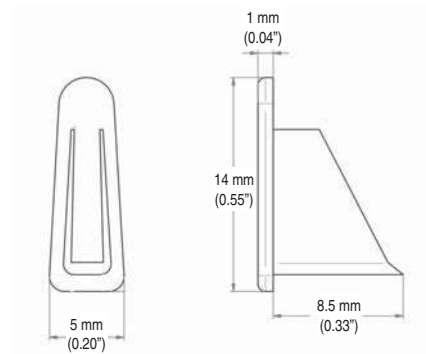

1492-A1E

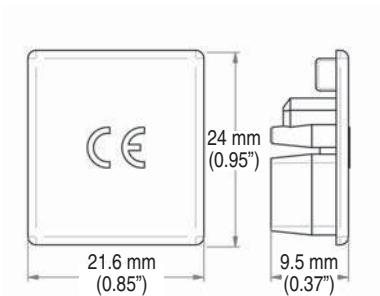

1492-AME

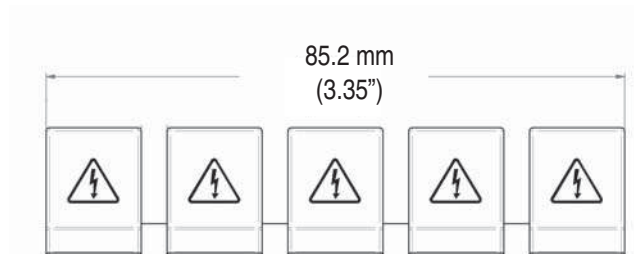

1492-AAP

1492-D Specifications

Electrical Ratings		
Poles	1, 2	
Tripping characteristics	C	
Rated current (I_n)	0.5...63 A	
Rated frequency (f)	0 Hz (DC only)	
Rated insulation voltage U_i per IEC/EN 60664-1	250V AC (phase to ground), 440V AC (phase to phase)	
Overvoltage category	III	
Pollution degree	3	
Data per UL/CSA		
Rated voltage	1-pole	250V DC
	2-pole	500V DC
Rated interrupting capacity per UL 1077	10 kA	
Application	Supplementary Protector for DC application use; application codes: TCO; OLO 250V DC, SC: 10kA; U1 250V DC; FWO	
Reference temperature for tripping characteristics	25 °C	
Electrical endurance	6,000 ops	
Data per IEC/EN 60947-2		
Rated operational voltage (U_e)	1-pole	220V DC
	2-pole	440V DC
Highest supply or utilization voltage (U_{max})	1-pole	250V DC
	2-pole	500V DC
Min. operating voltage	12V DC	
Rated ultimate short-circuit breaking capacity (I_{cu})	10 kA	
Rated service short-circuit breaking capacity (I_{cs})	10 kA	
Rated impulse withstand voltage U_{imp} . (1.2/50 μ s)	4 kV (test voltage 6.2kV at sea level, 5kV at 2,000m)	
Dielectric test voltage	2 kV (50/60Hz, 1 min.)	
Reference temperature for tripping characteristics	55 °C	
Electrical endurance 1 cycle (2s - ON, 13s - OFF, $I_n \leq 32A$), 1 cycle (2s - ON, 28s - OFF, $I_n > 32A$)	1,500 ops.	

Mechanical Data		
Housing	Insulation group II, RAL 7035	
Indicator window	red ON/green OFF	
Protection degree per EN 60529	IP20, IP40 in enclosure with cover	
Mechanical endurance	20,000 operations	
Shock resistance per IEC/EN 60068-2-27	25 g - 2 shocks - 13 ms	
Vibration resistance per IEC/EN 60068-2-6	5g - 20 cycles at 5...150...5 Hz with load 0.8In	
Environmental		
Environmental conditions (damp heat) per IEC/EN 60068-2-30	28 cycles with 55°C/90-96% and 25°C/95-100%	
Ambient temperature Δ	-25...+55 °C	
Storage temperature	-40...+70 °C	
Installation		
Terminal	Dual terminal	
Cross-section of wire \blacklozenge – solid, stranded (front/back terminal slot)	35/35 mm ²	
	18...4/18...10 AWG	
Cross-section of wire – flexible (front/back terminal slot)	25/10 mm ²	
	1 wire, 18...4 AWG 2-4 wires \ddagger , 18...10 AWG	
Multi-wire rating per UL, CSA	10 mm ²	
Cross-section of bus bars (back terminal slot)	2.8 N·m	
	AWG 18...16: 13.3 in·lb. AWG 14...10: 17.7 in·lb. AWG 8...4: 39.8 in·lb.	
Tightening torque	No. 2 Pozidrive	
Screwdriver	DIN rail (EN 60715, 35mm) with fast clip	
Mounting	Any	
Mounting position	Note polarity of device	
Supply	Approximate Dimensions and Weight	
Pole dimension (H x D x W)	88 x 69 x 17.5 mm	
Pole weight	125 g (4.5 oz.)	
Combination with Auxiliary Elements		
Auxiliary contact	Yes	
Signal contact	Yes	
Shunt trip	Yes	

\blacklozenge 35mm² self-declared, not included in IEC/EN approval.

Δ Refer to the ambient temperature derating tables.

\ddagger Wires must be of like size and stranding. Up to two wires per terminal slot.

Power Loss Due to Current

Rated Current [A]	Power Loss Per Pole [W]	Rated Current [A]	Power Loss Per Pole [W]
0.5	1.4	13	2.3
1	1.4	15	2.4
2	1.8	16	2.5
3	1.6	20	2.5
4	1.8	25	3.2
5	1.9	30	3.5
6	2.0	32	3.7
7	1.1	40	4.5
8	1.5	50	4.5
10	2.1	63	5.4

Zero-stack Derating

The installation of several miniature circuit breaker side by side with rated current on all poles requires a correction factor to the rated current (not required if spacers are used).

No. of Adjacent Devices	Factor
1	1
2,3	0.9
4,5	0.8
≥ 6	0.75

Approximate Dimensions

Note: Dimensions are shown in millimeters (inches). Dimensions are not intended for manufacturing purposes.

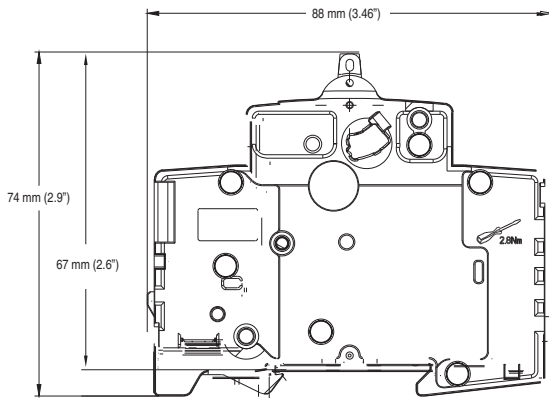

1-Pole

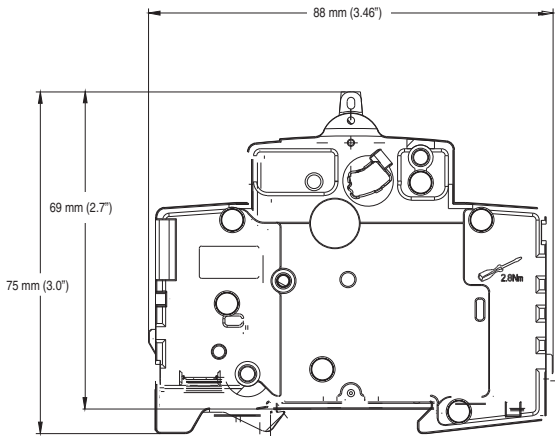
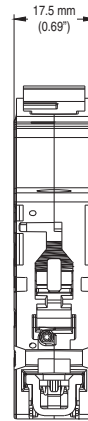

2-Pole

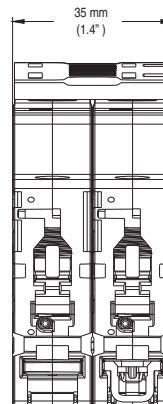

Ambient Temperature Derating

Note: Application below 0° C is for non-condensing atmosphere. Care should be taken for applications below 0 °C. These devices are not certified to operate correctly in the presence of ice.

Bulletin 1492-D

Temperature Derating, UL

Reference temperature = 40 °C

Current Rating (A)	Ambient temperature (°C)									
	-25	-20	-10	0	10	20	30	40	50	55
0.5	0.6	0.6	0.6	0.6	0.5	0.5	0.5	0.5	0.5	0.5
1	1.2	1.2	1.2	1.1	1.1	1.1	1.0	1	1.0	1.0
2	2.4	2.4	2.3	2.2	2.2	2.1	2.1	2	1.9	1.9
3	3.6	3.5	3.5	3.4	3.3	3.2	3.1	3	2.9	2.9
4	4.8	4.7	4.6	4.5	4.4	4.2	4.1	4	3.9	3.8
6	7.2	7.1	6.9	6.7	6.5	6.4	6.2	6	5.8	5.7
8	9.6	9.4	9.2	9.0	8.7	8.5	8.2	8	7.8	7.6
10	12.0	11.8	11.5	11.2	10.9	10.6	10.3	10	9.7	9.6
13	15.5	15.3	15.0	14.6	14.2	13.8	13.4	13	12.6	12.4
16	19.1	18.9	18.4	17.9	17.4	17.0	16.5	16	15.5	15.3
20	23.9	23.6	23.0	22.4	21.8	21.2	20.6	20	19.4	19.1
25	29.9	29.5	28.8	28.0	27.3	26.5	25.8	25	24.3	23.9
30	35.9	35.4	34.5	33.6	32.7	31.8	30.9	30	29.1	28.7
32	38.2	37.8	36.8	35.8	34.9	33.9	33.0	32	31.0	30.6
40	47.8	47.2	46.0	44.8	43.6	42.4	41.2	40	38.8	38.2
50	59.8	59.0	57.5	56.0	54.5	53.0	51.5	50	48.5	47.8
63	75.3	74.3	72.5	70.6	68.7	66.8	64.9	63	61.1	60.2

Bulletin 1492-D

Temperature Derating, IEC

Reference temperature = 30 °C

Current Rating (A)	Ambient temperature (°C)									
	-25	-20	-10	0	10	20	30	40	50	55
0.5	0.6	0.6	0.6	0.5	0.5	0.5	0.5	0.5	0.5	0.5
1	1.2	1.2	1.1	1.1	1.1	1.0	1	1.0	0.9	0.9
2	2.3	2.3	2.2	2.2	2.1	2.1	2	1.9	1.9	1.9
3	3.5	3.5	3.4	3.3	3.2	3.1	3	2.9	2.8	2.8
4	4.7	4.6	4.5	4.4	4.2	4.1	4	3.9	3.8	3.7
6	7.0	6.9	6.7	6.5	6.4	6.2	6	5.8	5.6	5.6
8	9.3	9.2	9.0	8.7	8.5	8.2	8	7.8	7.5	7.4
10	11.7	11.5	11.2	10.9	10.6	10.3	10	9.7	9.4	9.3
13	15.1	15.0	14.6	14.2	13.8	13.4	13	12.6	12.2	12.0
16	18.6	18.4	17.9	17.4	17.0	16.5	16	15.5	15.0	14.8
20	23.3	23.0	22.4	21.8	21.2	20.6	20	19.4	18.8	18.5
25	29.1	28.8	28.0	27.3	26.5	25.8	25	24.3	23.5	23.1
30	35.0	34.5	33.6	32.7	31.8	30.9	30	29.1	28.2	27.8
32	37.3	36.8	35.8	34.9	33.9	33.0	32	31.0	30.1	29.6
40	46.6	46.0	44.8	43.6	42.4	41.2	40	38.8	37.6	37.0
50	58.3	57.5	56.0	54.5	53.0	51.5	50	48.5	47.0	46.3
63	73.4	72.5	70.6	68.7	66.8	64.9	63	61.1	59.2	58.3

Tripping Characteristics

C Curve

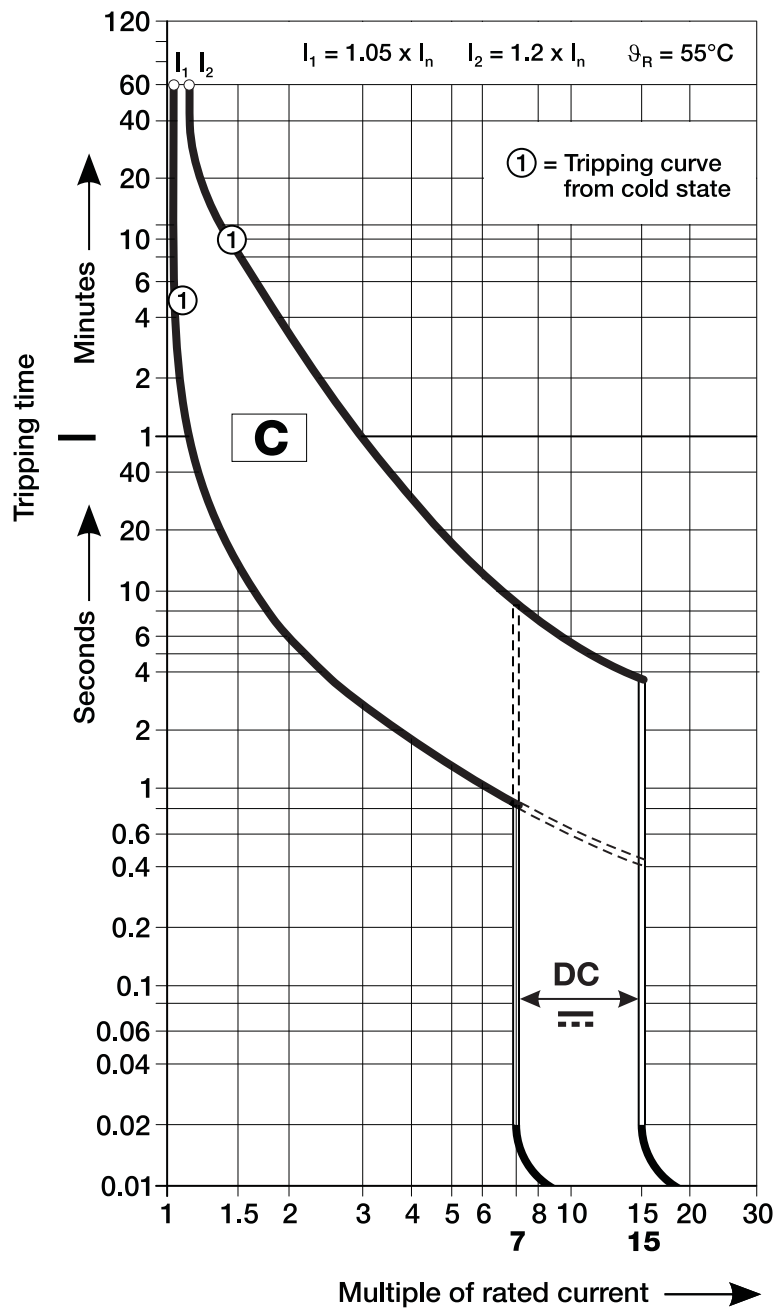

Circuit Breaker Accessory Approximate Dimensions

Note: Dimensions are shown in millimeters (inches). Dimensions are not intended for manufacturing purposes.

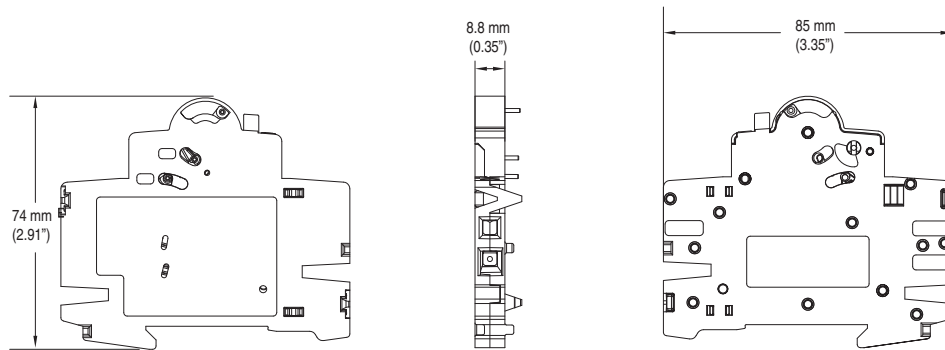

189-ASCR3

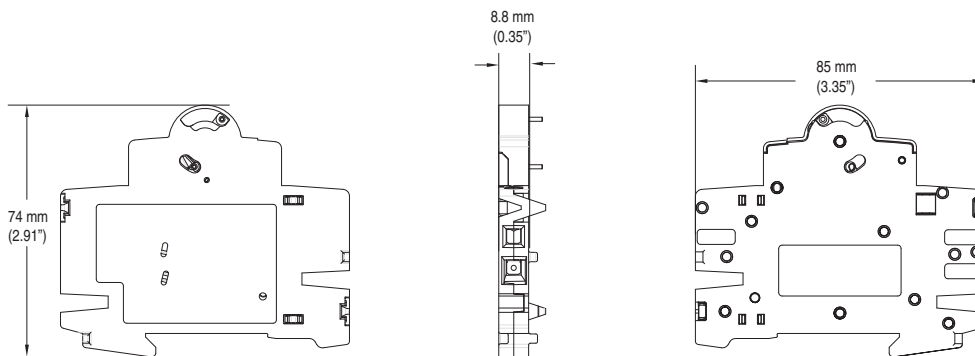

189-AR3

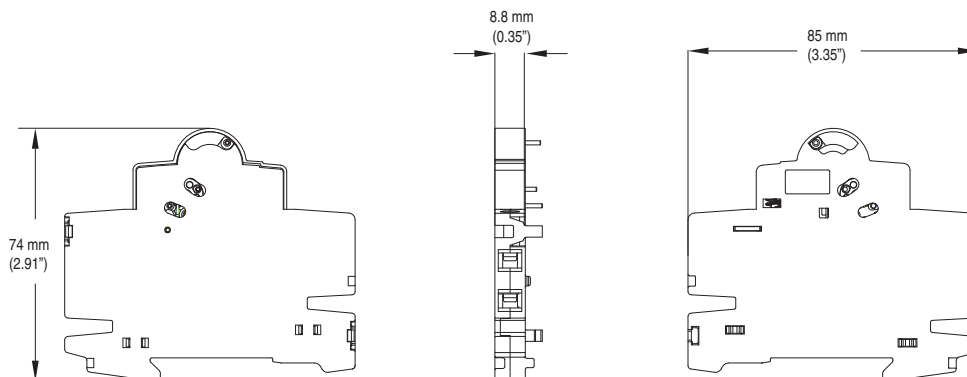

189-AR11, 189-AR02, 189-AR20

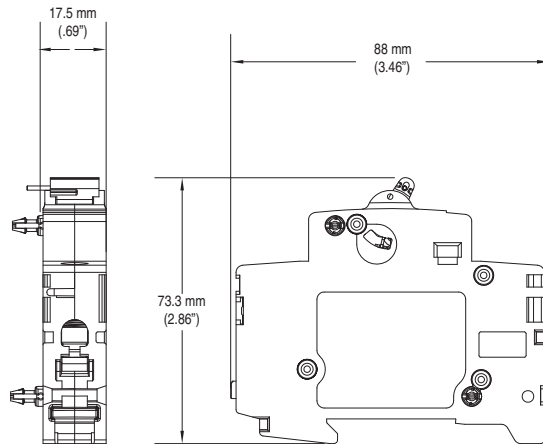

189-AST1 and 189-AST2

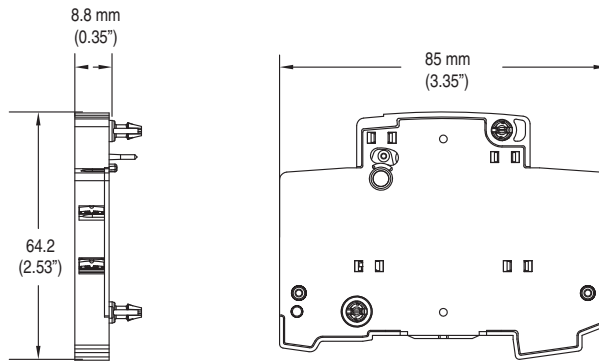

189-AL11, 189-AL02, and 189-AL20

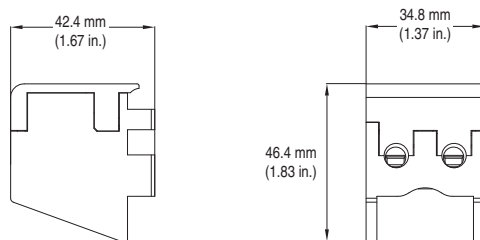

189-AB01 and 189-AB10

Bus Bar Approximate Dimensions

Note: Dimensions are shown in millimeters. Dimensions are not intended for manufacturing purposes.

1-Phase Bus Bars

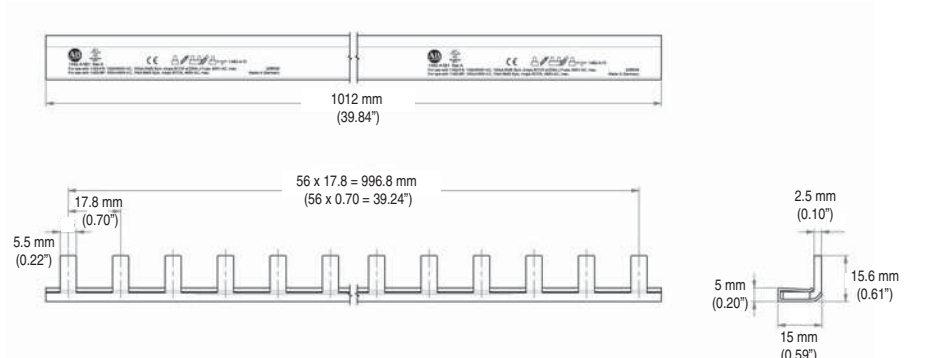

1492-A1B1

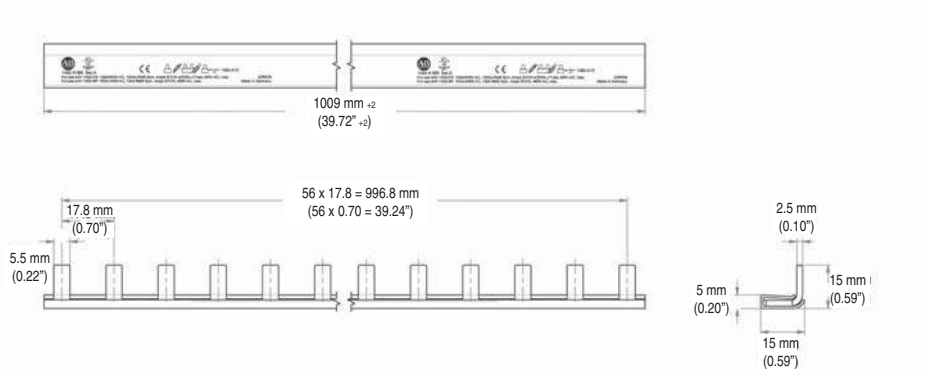

1492-A1B8

1-Phase Bus Bars, with Auxiliary Contact

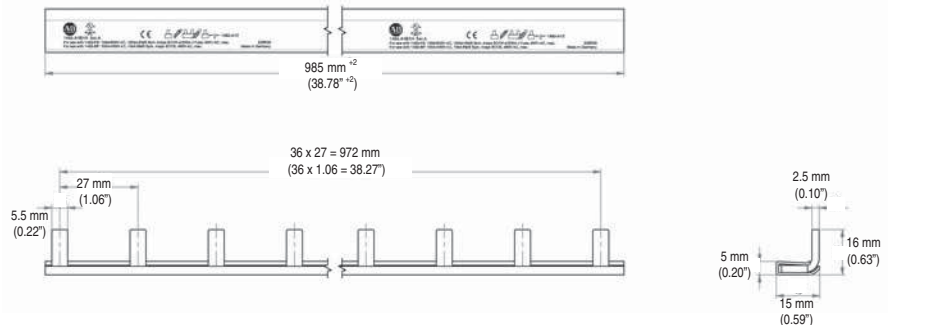

1492-A1B1H

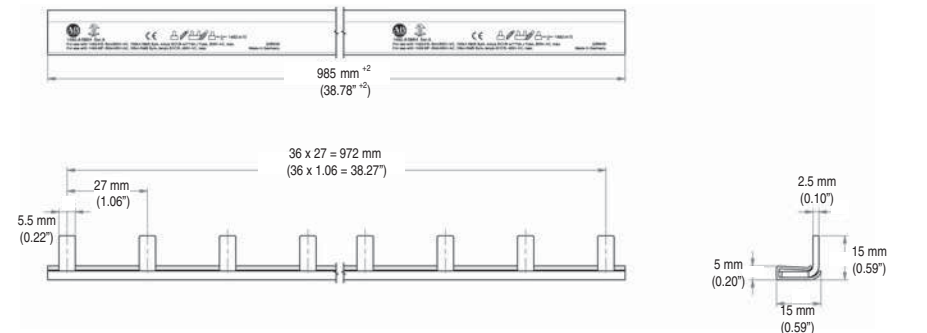

1492-A1B8H

2-Phase Bus Bars

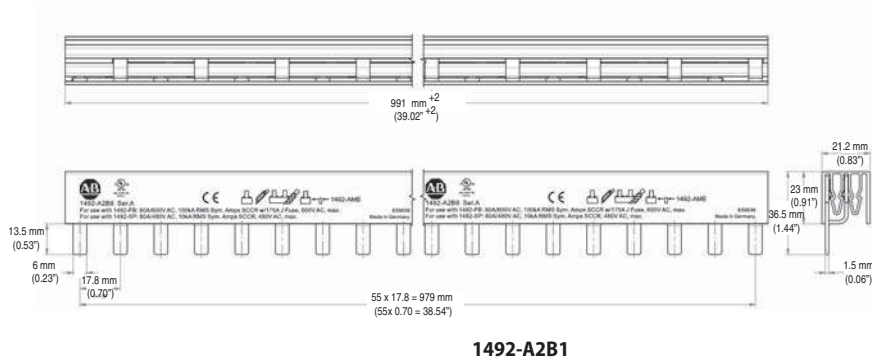

1492-A2B1

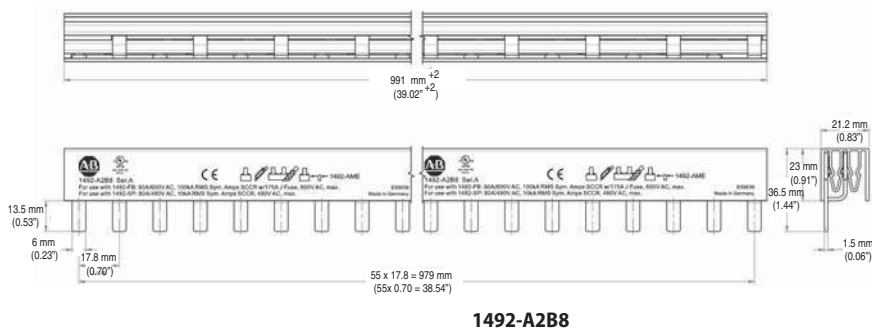

1492-A2B8

2-Phase Bus Bars, with Auxiliary Contact

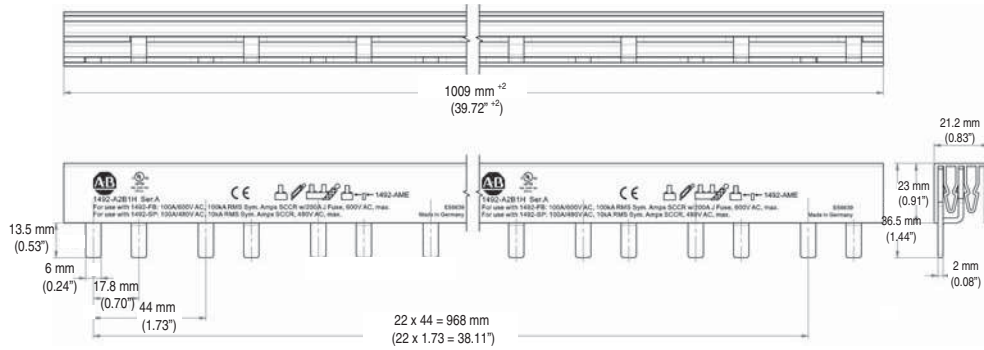

1492-A2B1H

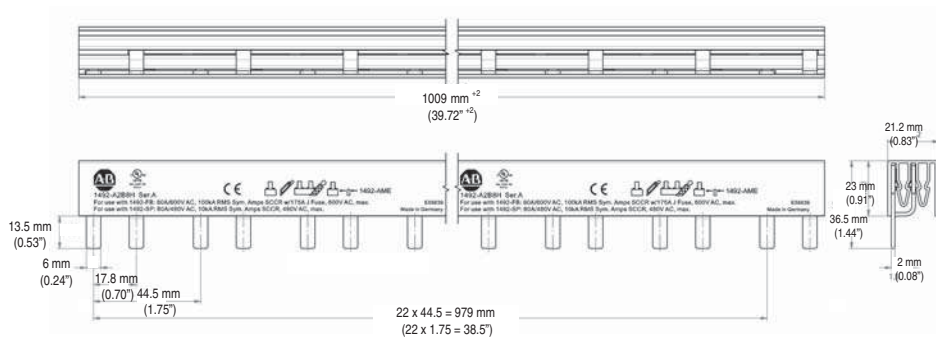

1492-A2B8H

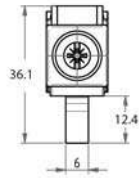
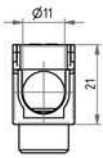

1492-AAT1LP

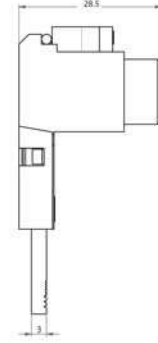
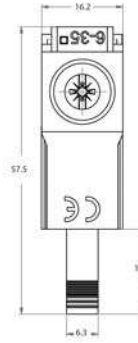

1492-AAT1S

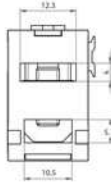
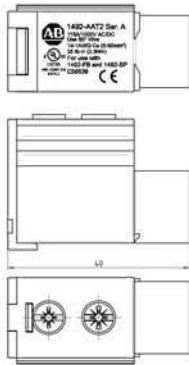
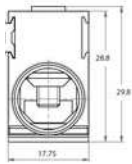

1492-AAT2

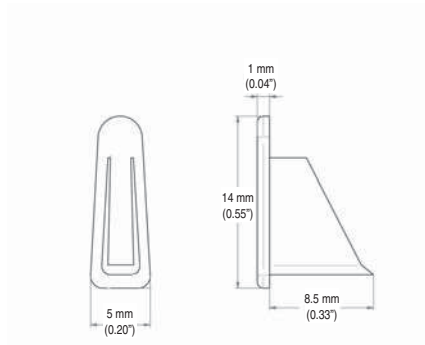

1492-A1E

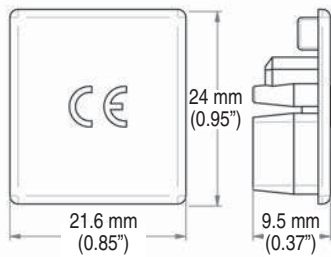

1492-AME

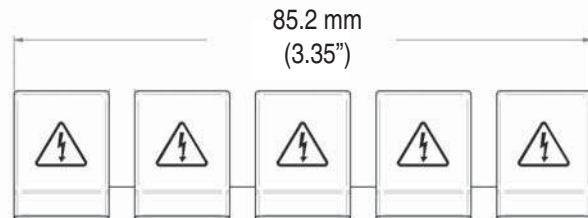

1492-AAP

188 Specifications

General Data			
Poles	1, 2, 3, 4, 1+N, 3+N		
Tripping characteristics	B, C, D		
Rated current (I_n)	0.5...63 A		
Rated frequency (f)	50/60 Hz		
Rated insulation voltage U_i per IEC/EN 60664-1	250 V AC (phase to ground), 440V AC (phase to phase)		
Overvoltage category	III		
Pollution degree	2		
Data per IEC/EN 60898-1			
Rated operational voltage (U_e)	1-pole	230/400V AC	
	1-pole +N	230V AC	
	2-, 3-, 4-pole 3-pole +N	400V AC	
Highest supply or utilization voltage (U_{max})	AC	1-pole	253/440V AC
		1-pole+N	253V AC
	DC★	2-, 3-, 4-, 3-pole+N	440V AC
		1-pole	48V DC
	2-pole	96V DC	
Min. operating voltage	12V AC, 12V DC		
Rated short-circuit capacity (I_{cn})	188-J	10 kA	
	188-K	6 kA	
Energy limiting class (B, C up to 40 A)	3		
Rated impulse withstand voltage U_{imp} . (1.2/50 μ s)	4 kV (test voltage 6.2kV at sea level, 5kV at 2,000m)		
Dielectric test voltage	2 kV (50 / 60Hz, 1 min.)		
Reference temperature for tripping characteristics	B, C, D: 30°C		
Electrical endurance	$I_n < 30A$: 20,000 ops (AC) $I_n \geq 30A$: 10,000 ops. (AC); 1,000 ops. (DC);		

★ IEC DC ratings self-declared.

Power Loss Due to Current

Rated Current [A]	Power Loss Per Pole [W]	Rated Current [A]	Power Loss Per Pole [W]
0.5	1.4	13	2.3
1	1.4	16	2.5
2	1.8	20	2.5
3	1.5	25	3.2
4	1.8	32	3.7
6	2.0	40	4.8
8	1.5	50	4.5
10	2.1	63	5.2

Mechanical Data	
Housing	Insulation group II, RAL 7035
Indicator window	None
Protection degree per EN 60529	IP20— IP40 in enclosure with cover
Mechanical endurance	20,000 operations
Shock resistance per IEC/EN 60068-2-27	25 g - 2 shocks - 13 ms
Vibration resistance per IEC/EN 60068-2-6	5g - 20 cycles at 5...150...5 Hz with load 0.8In

Environmental	
Environmental conditions (damp heat) per IEC/EN 60068-2-30	28 cycles with 55°C/90-96% and 25°C/95-100%
Ambient temperature★	-25...+55°C
Storage temperature	-40...+70°C

Installation	
Terminal	Cage terminal
Cross-section of wire solid, stranded	0.75...25 mm ²
Cross-section of wire flexible	0.75...16 mm ²
Tightening torque	2.0 N·m
Screwdriver	No. 2 Pozidrive
Mounting	DIN Rail (EN 60715, 35mm) with fast clip
Mounting position	Any
Supply	Optional

Approximate Dimensions and Weight	
Pole dimensions (H x D x W)	85 x 69 x 17.5 mm
Pole weight	115 g (4.4 oz.)

Combination with aux. elements	
Auxiliary contact	Yes
Signal contact	Yes
Shunt trip	Yes

★ Refer to the Ambient Temperature Derating tables.

Zero-stack Derating

The installation of several miniature circuit breaker side by side with rated current on all poles requires a correction factor to the rated current (not required if spacers are used).

No. of Adjacent Devices	Factor
1	1
2,3	0.9
4,5	0.8
≥6	0.75

Approximate Dimensions

Note: Dimensions are shown in millimeters (inches). Dimensions are not intended for manufacturing purposes.

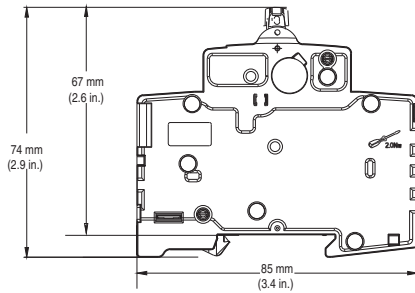

1-Pole

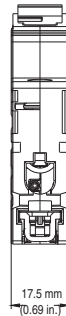

1-Pole

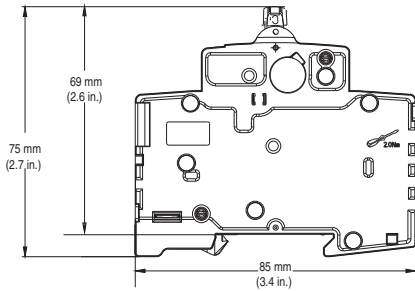

1+N, 2-, 3-, 3+N, 4-Pole

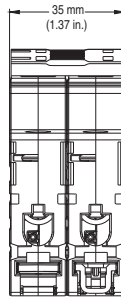

1-Pole +N, 2-Pole

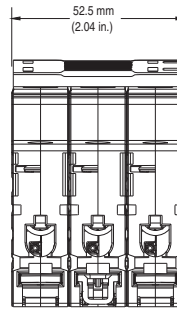

3-Pole

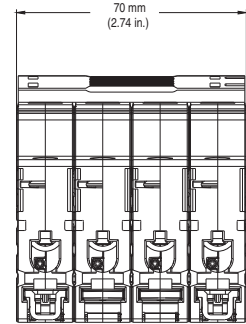

3-Pole +N, 4-Pole

Ambient Temperature Derating

Note: Application below 0° C is for non-condensing atmosphere. Care should be taken for applications below 0 °C. These devices are not certified to operate correctly in the presence of ice.

Bulletin 188-J

Temperature Derating, IEC

Reference temperature = 30 °C

Current Rating [A]	Ambient temperature (°C)									
	-25	-20	-10	0	10	20	30	40	50	55
0.5	0.6	0.6	0.6	0.6	0.5	0.5	0.5	0.5	0.5	0.5
1	1.2	1.2	1.1	1.1	1.1	1.0	1.0	1.0	0.9	0.9
2	2.3	2.3	2.2	2.2	2.1	2.1	2.0	1.9	1.9	1.9
3	3.5	3.5	3.4	3.3	3.2	3.1	3.0	2.9	2.8	2.8
4	4.7	4.6	4.5	4.4	4.2	4.1	4.0	3.9	3.8	3.7
6	7.0	6.9	6.7	6.5	6.4	6.2	6.0	5.8	5.6	5.6
8	9.3	9.2	9.0	8.7	8.5	8.2	8.0	7.8	7.5	7.4
10	11.7	11.5	11.2	10.9	10.6	10.3	10	9.7	9.4	9.3
13	15.1	15.0	14.6	14.2	13.8	13.4	13	12.6	12.2	12.0
16	18.6	18.4	17.9	17.4	17.0	16.5	16	15.5	15.0	14.8
20	23.3	23.0	22.4	21.8	21.2	20.6	20	19.4	18.8	18.5
25	29.1	28.8	28.0	27.3	26.5	25.8	25	24.3	23.5	23.1
32	37.3	36.8	35.8	34.9	33.9	33.0	32	31.0	30.1	29.6
40	46.6	46.0	44.8	43.6	42.4	41.2	40	38.8	37.6	37.0
50	58.3	57.5	56.0	54.5	53.0	51.5	50	48.5	47.0	46.3
63	73.4	72.5	70.6	68.7	66.8	64.9	63	61.1	59.2	58.3

Tripping Characteristics

B Curve

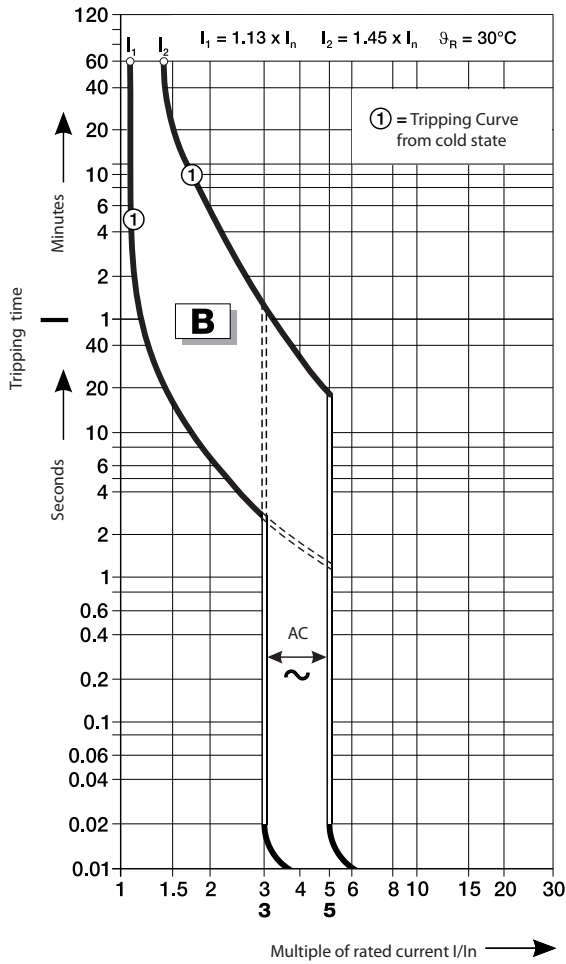

B and C Curve - 230/400V AC Let-through Energy

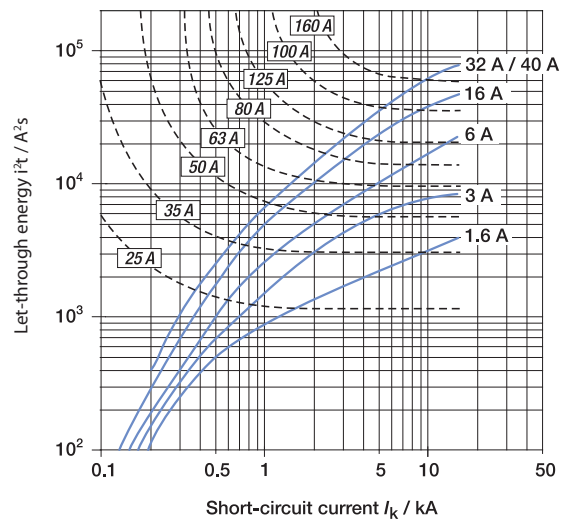
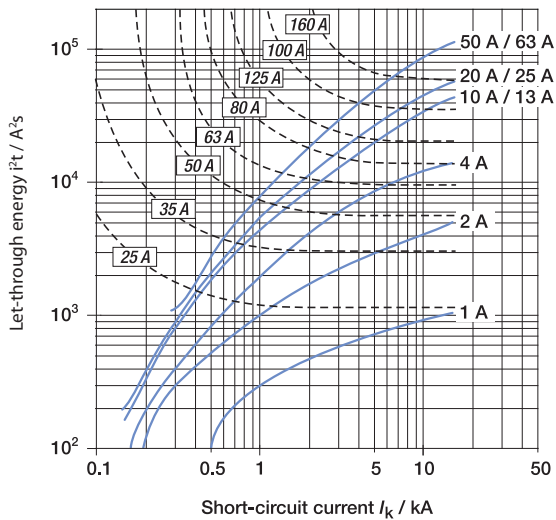

Tripping Characteristics

C Curve

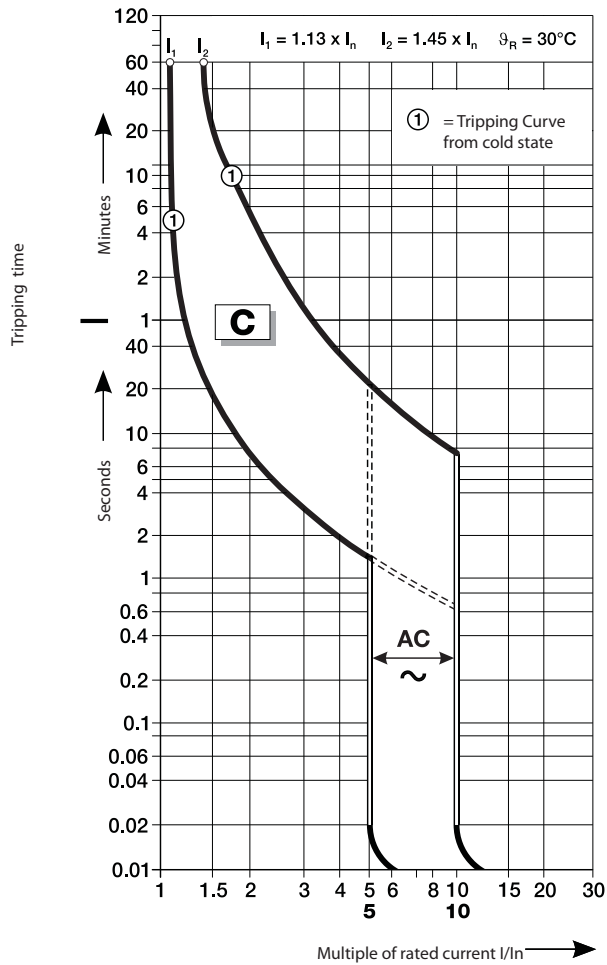

B and C Curve - 230/400V AC Let-through Energy

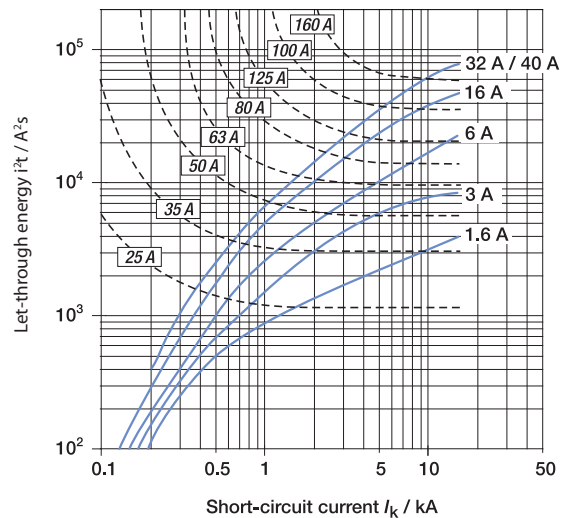
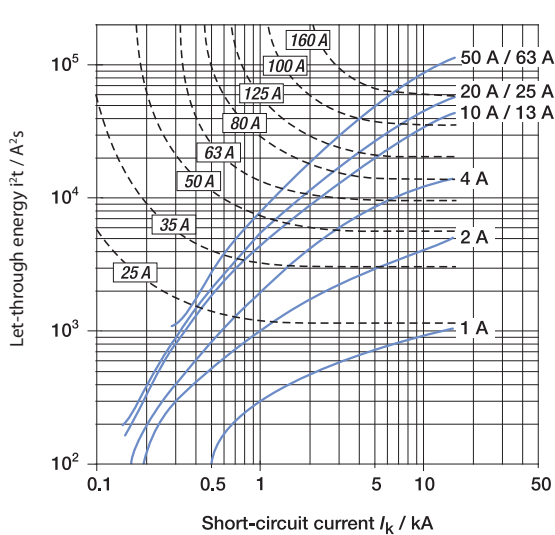

Tripping Characteristics

D Curve

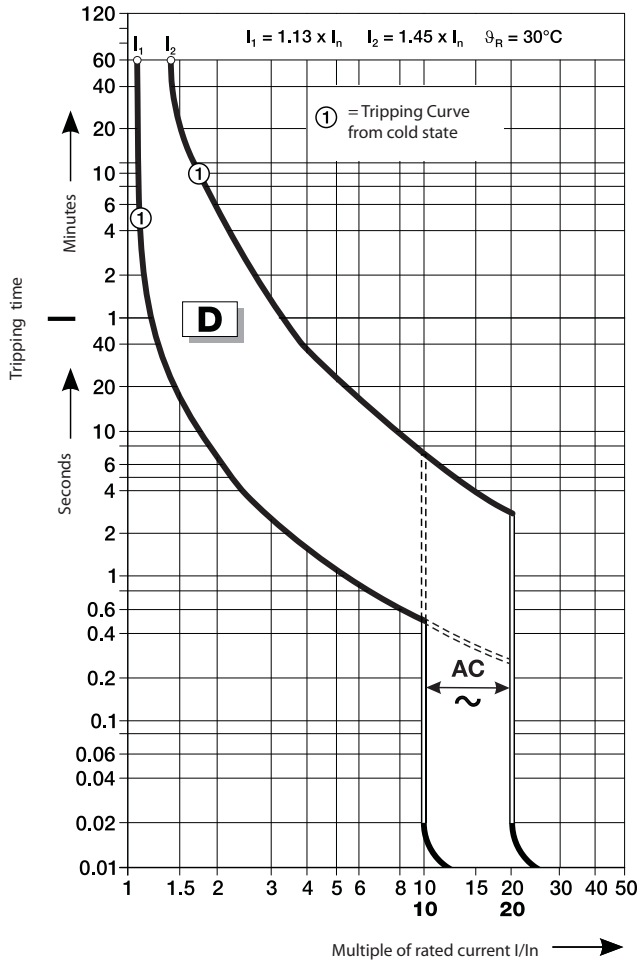

D Curve - 230/400V AC Let-through Energy

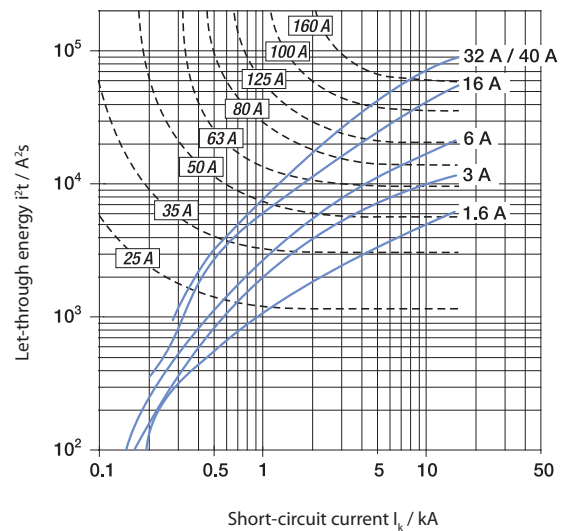
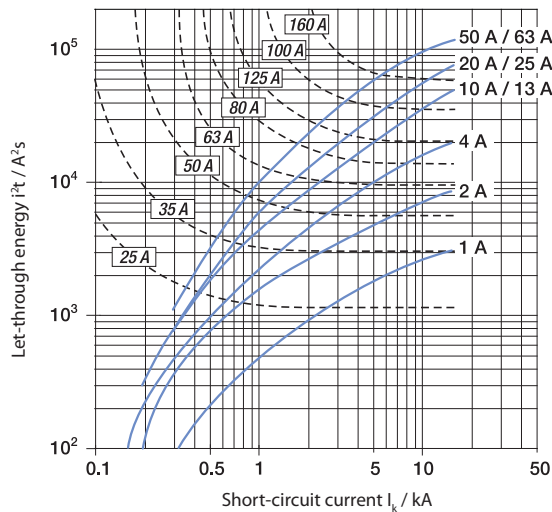

Accessory Approximate Dimensions

Note: Dimensions are shown in millimeters (inches). Dimensions are not intended for manufacturing purposes.

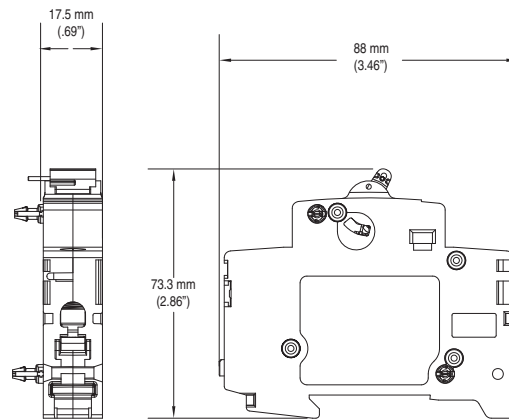

189-AST1 and 189-AST2

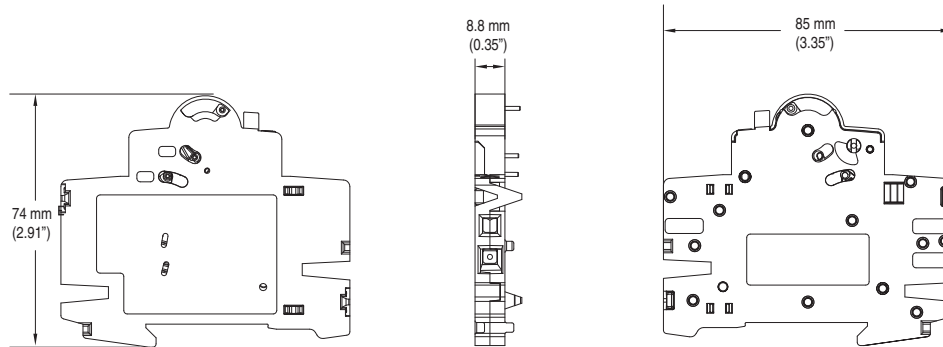

189-ASCR3

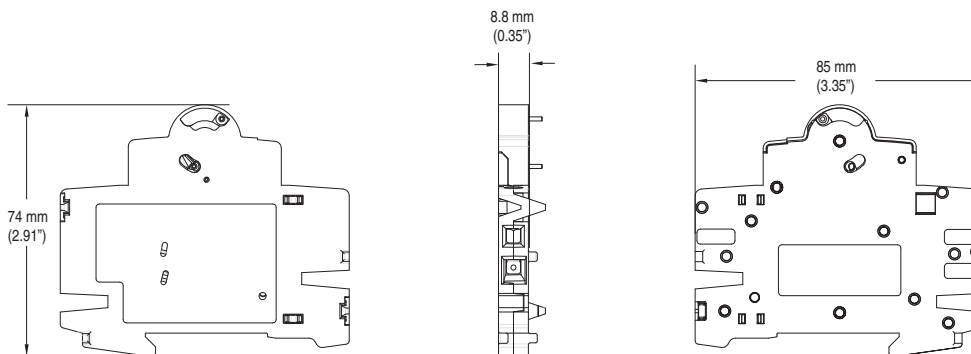

189-AR3

Accessory Approximate Dimensions

Note: Dimensions are shown in millimeters (inches). Dimensions are not intended for manufacturing purposes.

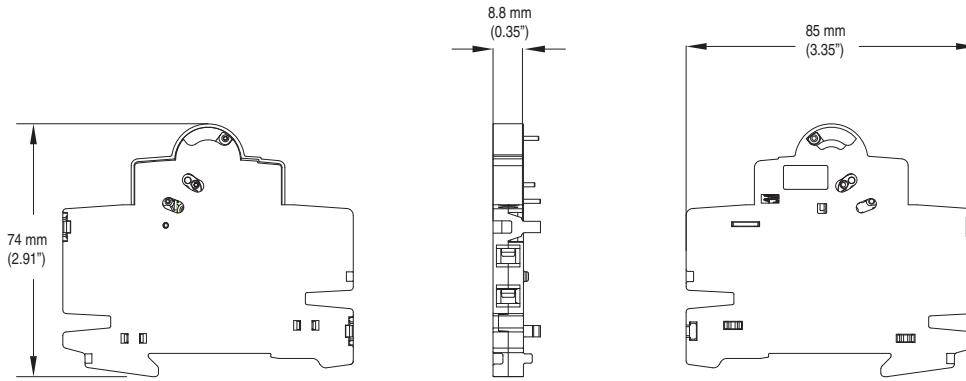

189-AR11, 189-AR02, 189-AR20

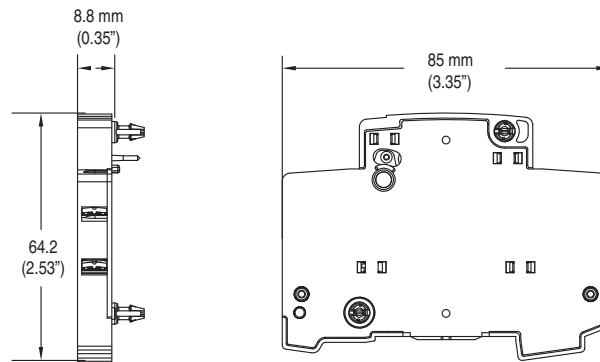

189-AL11, 189-AL02, and 189-AL20

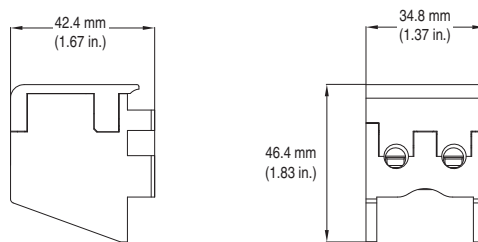

189-AB01 and 189-AB10

Bus Bar Approximate Dimensions

Note: Dimensions are shown in millimeters (inches). Dimensions are not intended for manufacturing purposes.

1-Phase Bus Bars

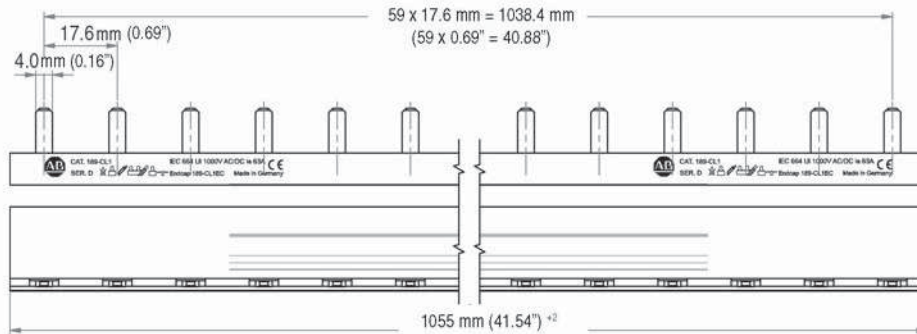

189-CL1

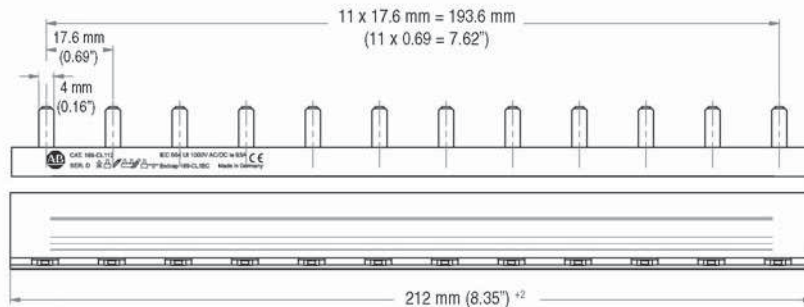

189-CL112

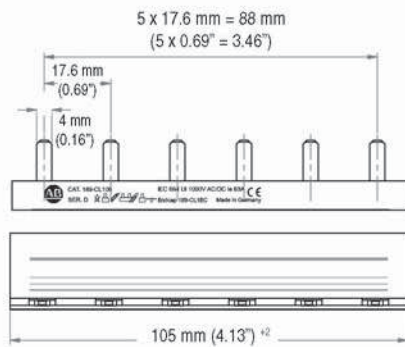
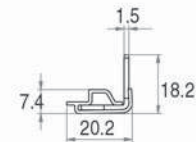

189-CL106

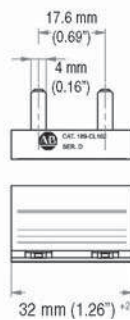

189-CL102

Bus Bar Approximate Dimensions

Note: Dimensions are shown in millimeters (inches). Dimensions are not intended for manufacturing purposes.

1-Phase Bus Bars, with Auxiliary Contact

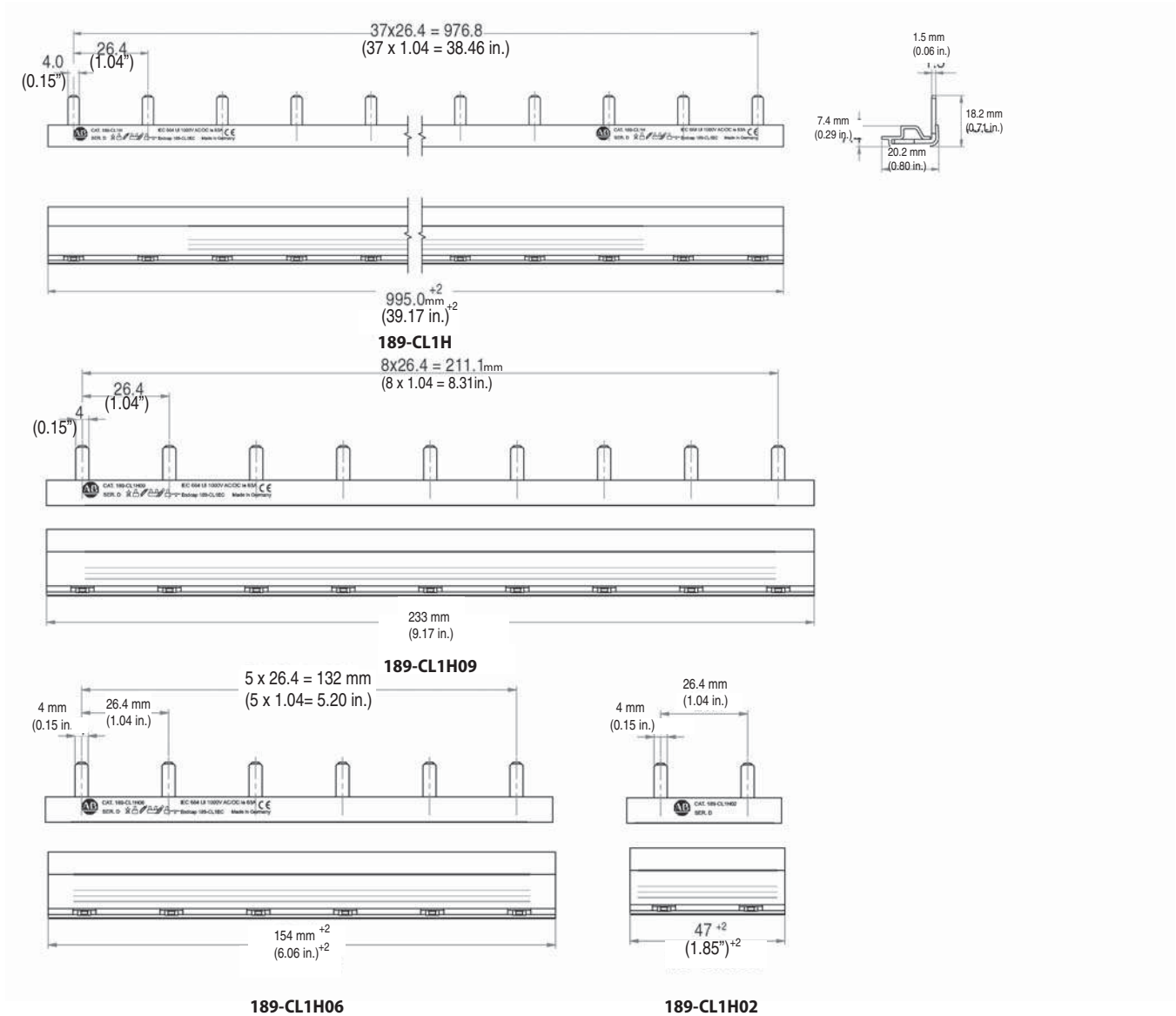

Bus Bar Approximate Dimensions

Note: Dimensions are shown in millimeters (inches). Dimensions are not intended for manufacturing purposes.

2-Phase Bus Bars

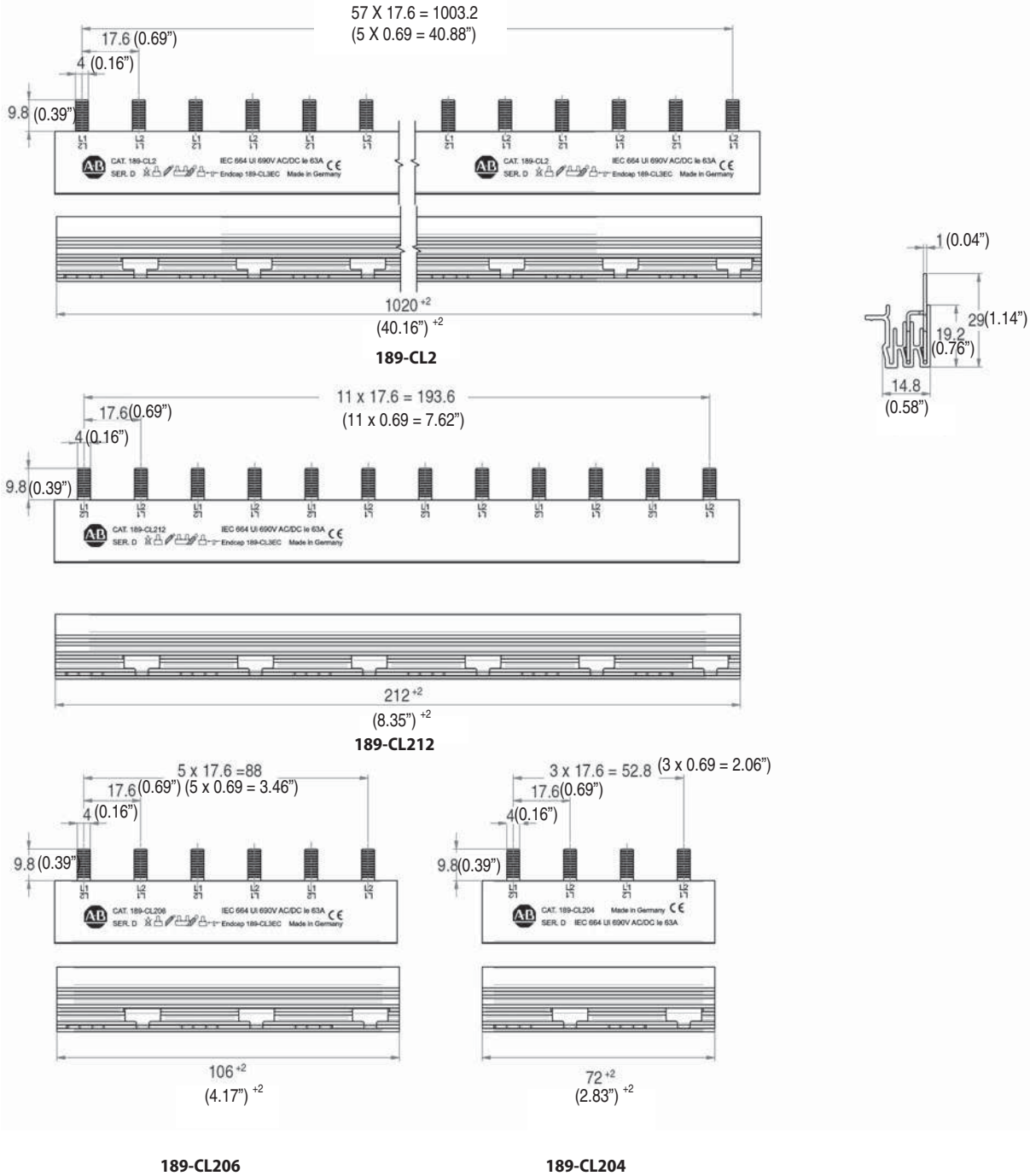

Bus Bar Approximate Dimensions

Note: Dimensions are shown in millimeters (inches). Dimensions are not intended for manufacturing purposes.

2-Phase Bus Bars, with Auxiliary Contact

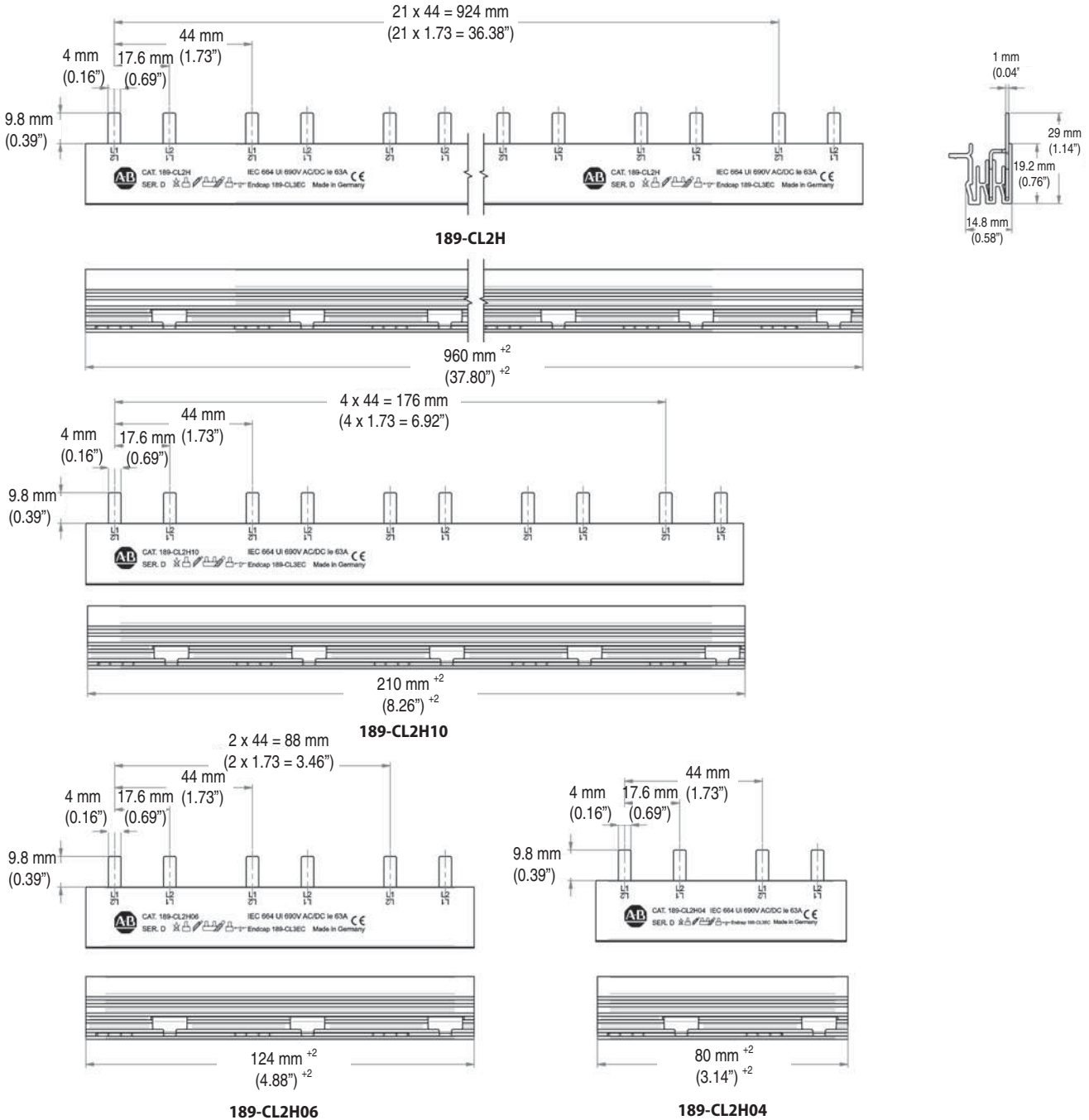

Bus Bar Approximate Dimensions

Note: Dimensions are shown in millimeters (inches). Dimensions are not intended for manufacturing purposes.

3-Phase Bus Bars

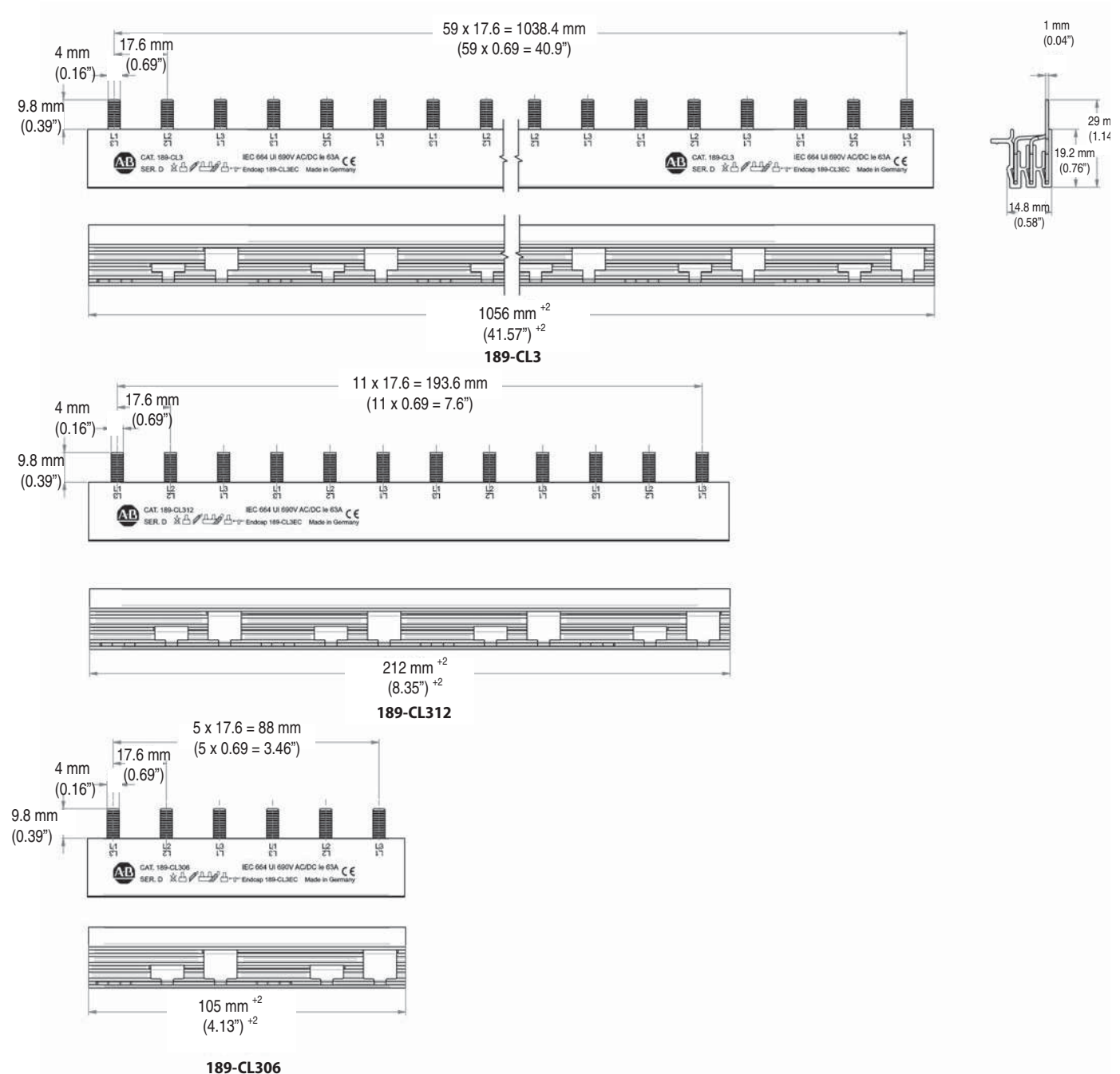

Bus Bar Approximate Dimensions

Note: Dimensions are shown in millimeters (inches). Dimensions are not intended for manufacturing purposes.

3-Phase Bus Bars, with Auxiliary Contact

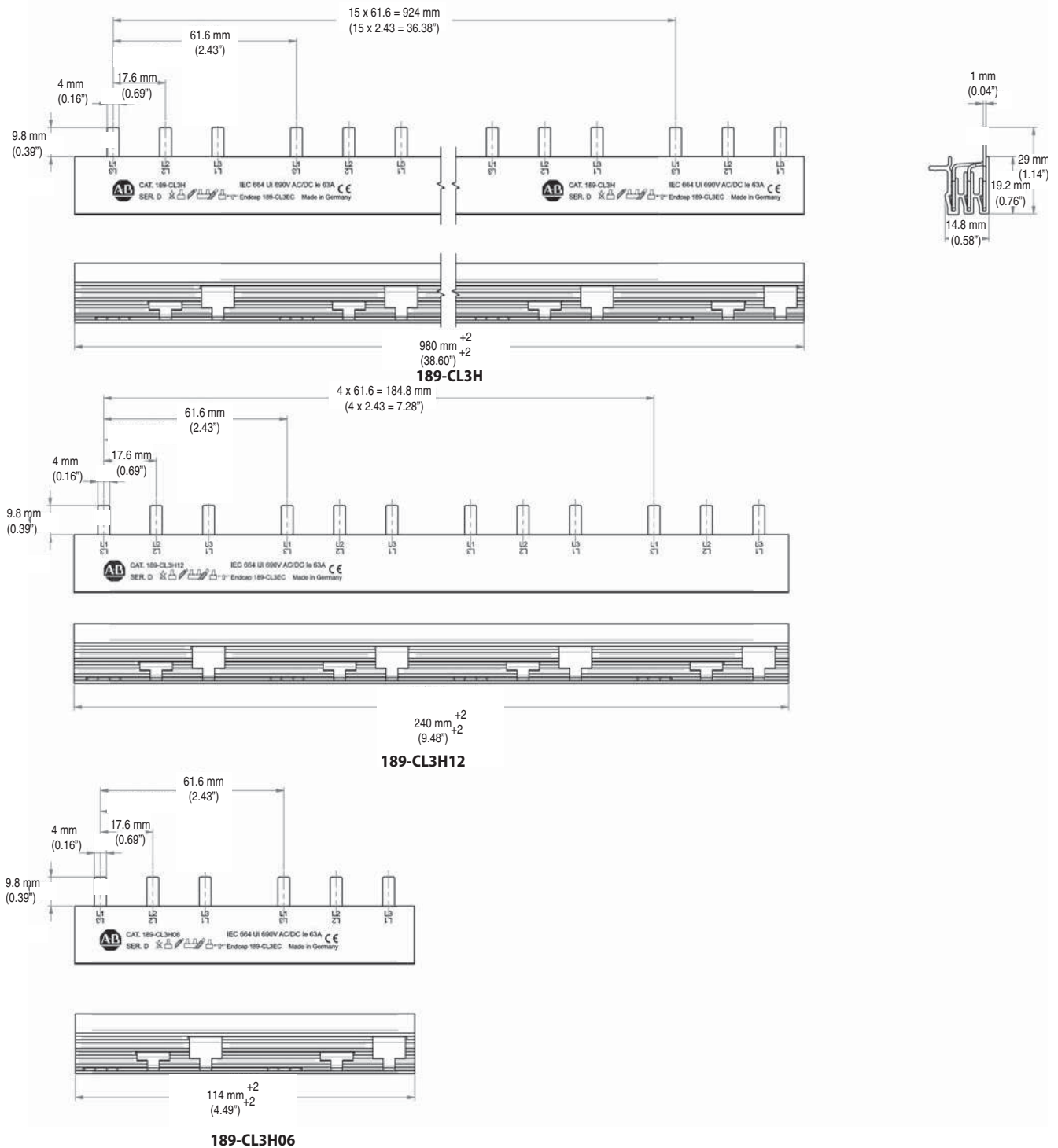

Bus Bar Approximate Dimensions

Note: Dimensions are shown in millimeters (inches). Dimensions are not intended for manufacturing purposes.

4-Phase Bus Bars

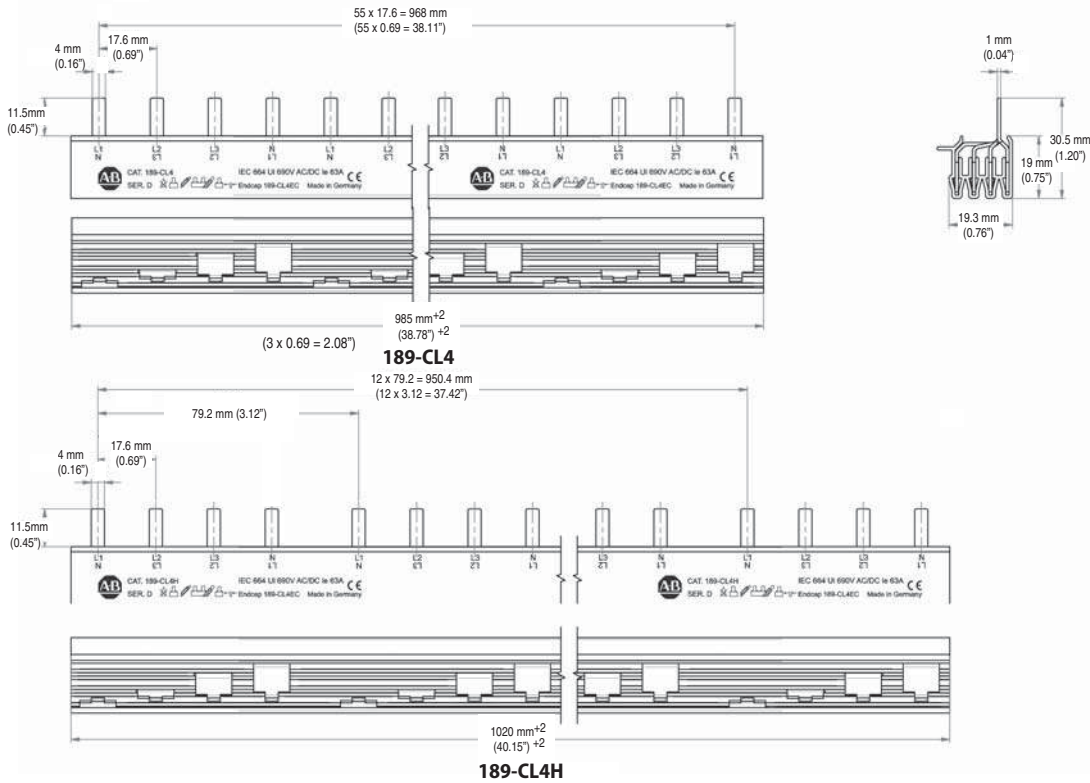

2- and 4-Phase Bus Bars for connection to 1492-RCD

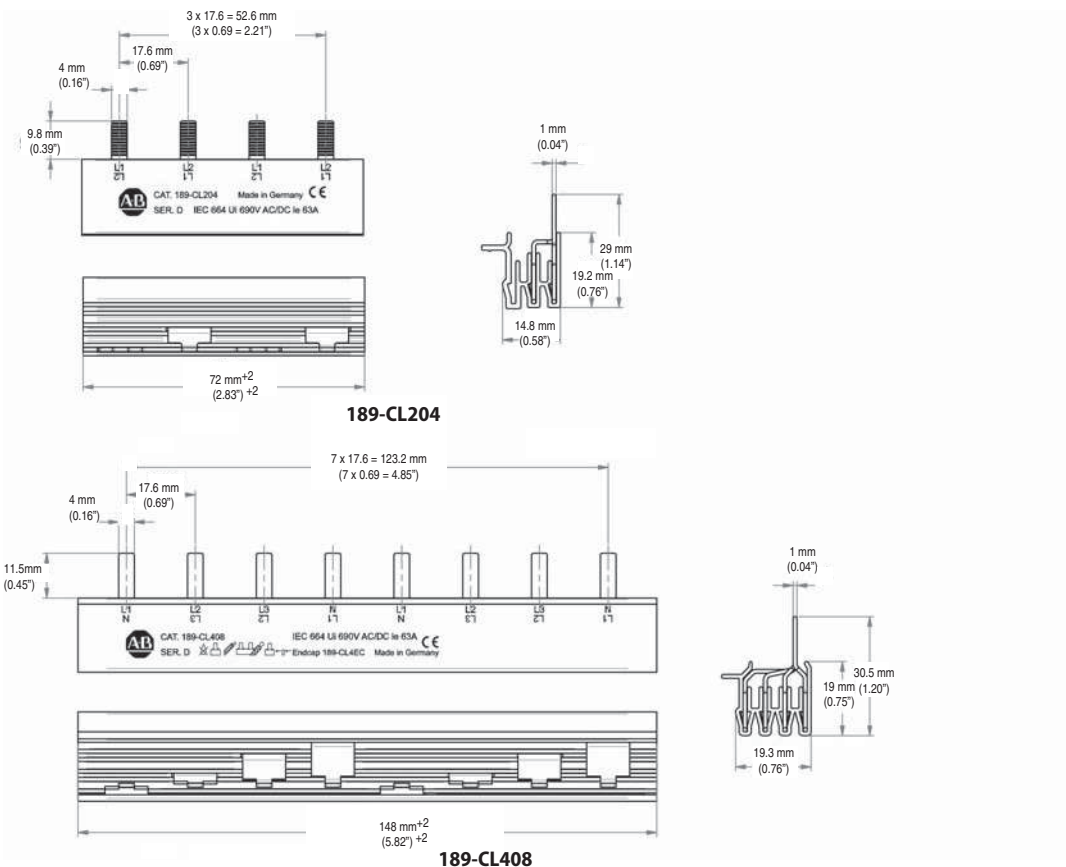

Bus Bar Accessory Approximate Dimensions

Note: Dimensions are shown in millimeters. Dimensions are not intended for manufacturing purposes.

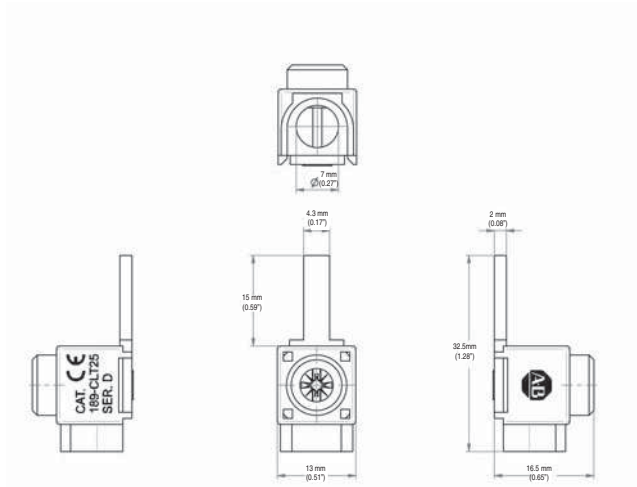

189-CLT25

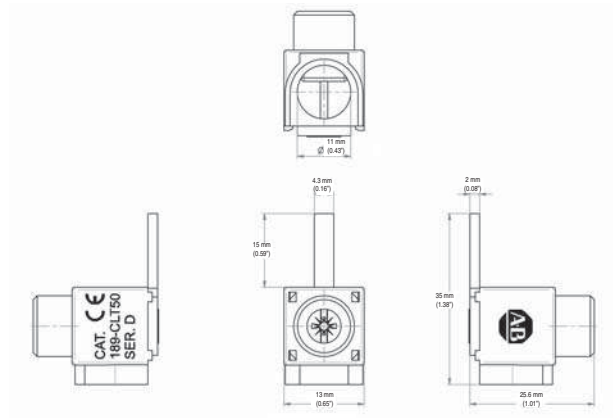

189-CLT50

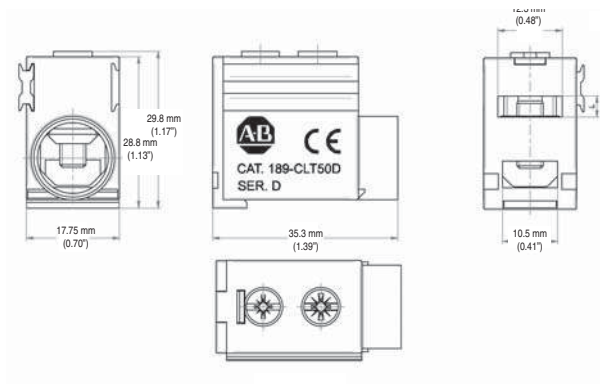

189-CLT50D

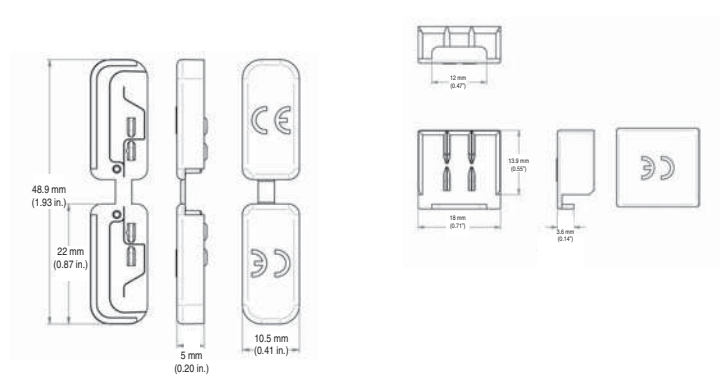

189-CL1EC

189-CL3EC

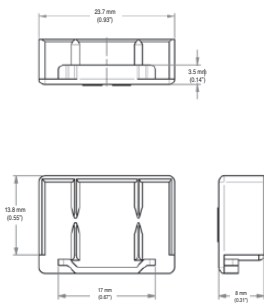

189-CL4EC

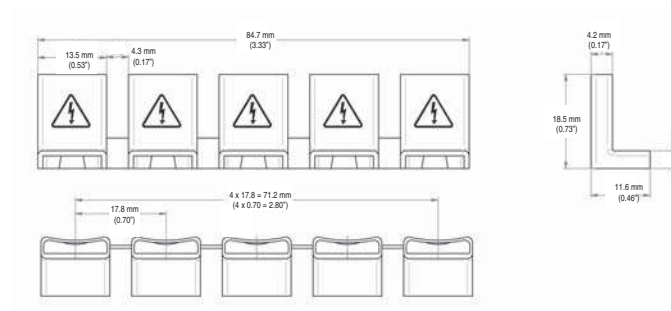

189-CLPS

1492-RCD Specifications

General Data		
Poles	2,4	
Rated current I_n	25, 40, 63, 80 A	
Rated sensitivity $I_{\Delta n}$	2-pole	30, 100, 300 mA
	4-pole	30, 100, 300, 500 mA
Electrical Ratings		
Rated short-circuit strength	10 kA with 63 A gG/gL back-up fuse, 10 kA with 80 A gG/gL back-up fuse for 80 A device	
Rated operational voltage U_e per IEC/EN	230/400V AC	
Rated voltage U_e per UL	480Y/277V AC	
Max. operating voltage of circuit test	254V AC	
Min. operating voltage of circuit test	110V	
Rated frequency	50/60 Hz	
Rated conditional short-circuit	10 kA (SCPD - fuse gG 100 A)	
Rated residual breaking capacity	1 kA	
Rated impulse withstand voltage U_{imp} (1.2/50 μ s)	4 kV	
Dielectric test voltage at ind. freq. for 1 min.	2.5 kV	
Electrical endurance	10,000 operations	
Mechanical		
Indicator window	Red ON/green OFF	
Protection degree	Housing	IP4X
	Terminals	IP2X
Environmental		
Ambient temperature (with daily average +35 °C)	-25...+55 °C	
Storage temperature	-40...+70 °C	
Mechanical endurance	20,000 operations	
Installation		
Terminal type	Dual terminal	
Cross-section of wire - solid, stranded, flexible (front/back terminal slot)	25...63 A	25/25 mm ²
		18...4 AWG
	80 A	35/35 mm ²
		18...2 AWG
Cross-section of bus bars (front/back terminal slot)	25...63 A	10/10 mm ²
	80 A	16/16 mm ²
Tightening torque	25...63 A	2.8 N·m
		25 in·lb
	80 A	4.8 N·m
		43 in·lb
Mounting	DIN Rail EN 60715 (35 mm) with fast clip device	
Supply	Optional	

Approximate Dimensions and Weight		
Dimensions (H x D x W)	2-pole	88 x 67 x 35 mm
	4-pole	88 x 67 x 70 mm
Weight	2-pole	200 g (7.1 oz.)
	4-pole	350 g (12.3 oz.)
Combination with Auxiliary Elements		
Auxiliary contact	Yes	
Signal contact	Yes	

Power Loss Due to Current

Rated Current [A]	Power Loss [W]	
	2-pole	4-pole
25	1	1.3
40	2.4	3.2
63	3.2	4.4
80	8.8	33.3

Approximate Dimensions

Note: Dimensions are shown in millimeters (inches). Dimensions are not intended for manufacturing purposes.

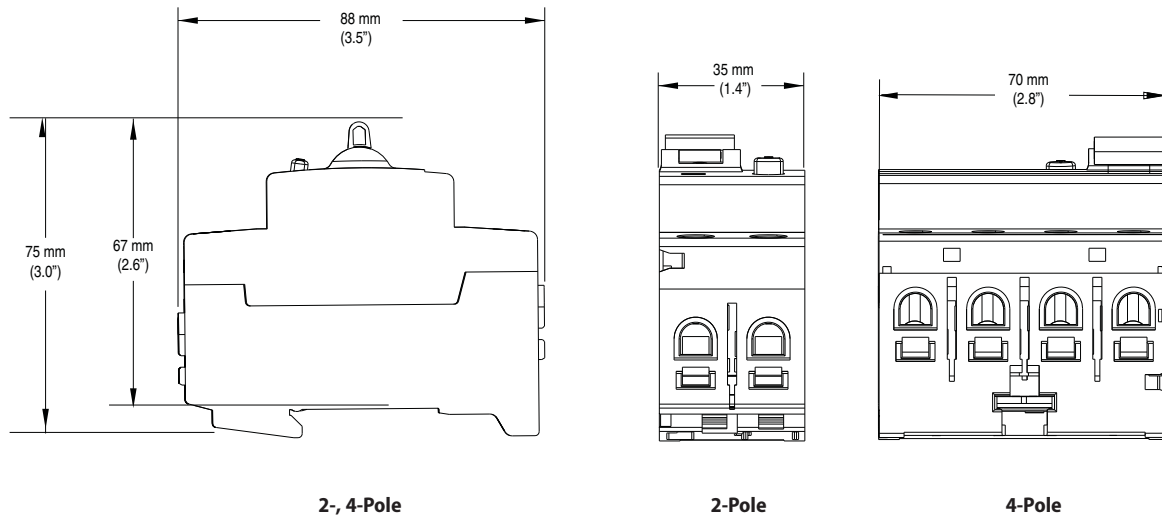

Accessory Approximate Dimensions

Note: Dimensions are shown in millimeters (inches). Dimensions are not intended for manufacturing purposes.

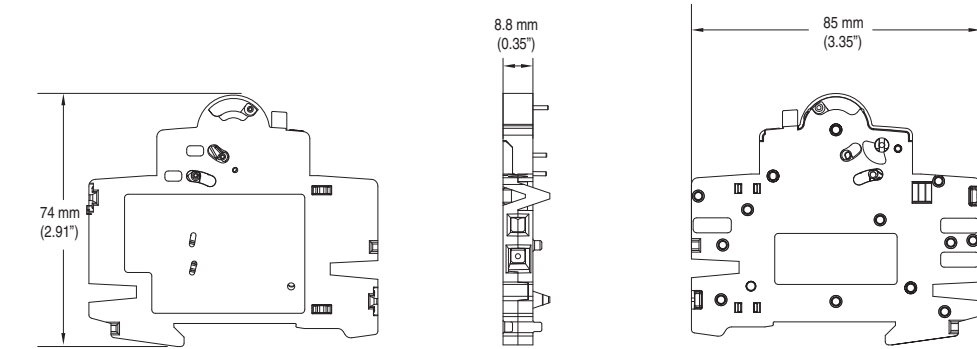

189-ASCR3

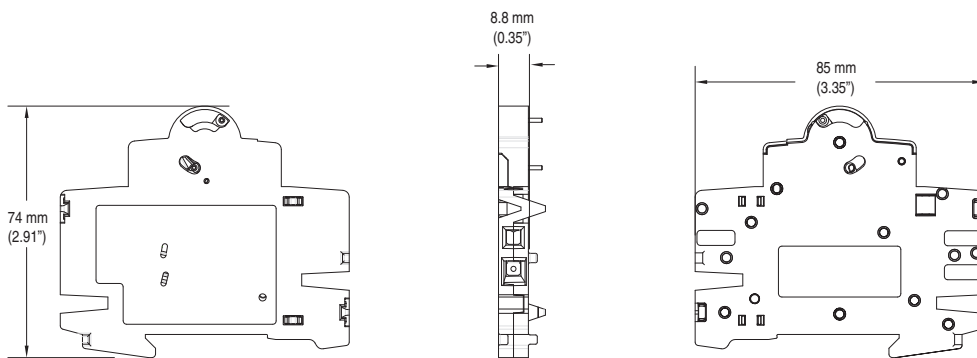

189-AR3

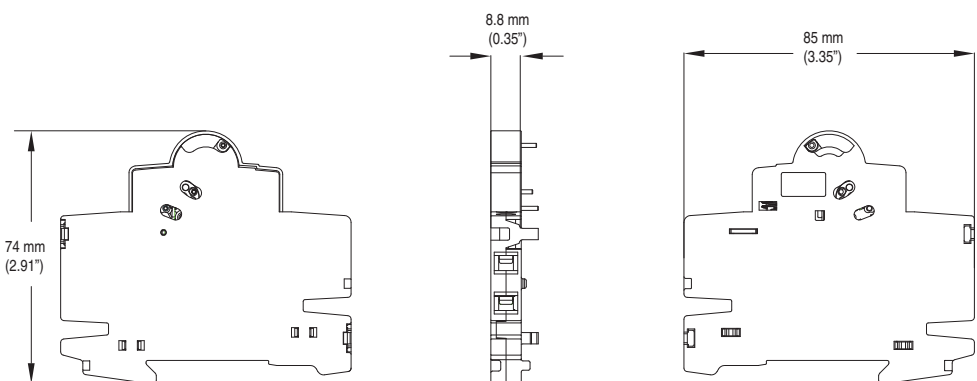

189-AR11, 189-AR02, 189-AR20

Bus Bar Approximate Dimensions

Note: Dimensions are shown in millimeters (inches). Dimensions are not intended for manufacturing purposes.

2- and 4-Phase Bus Bars

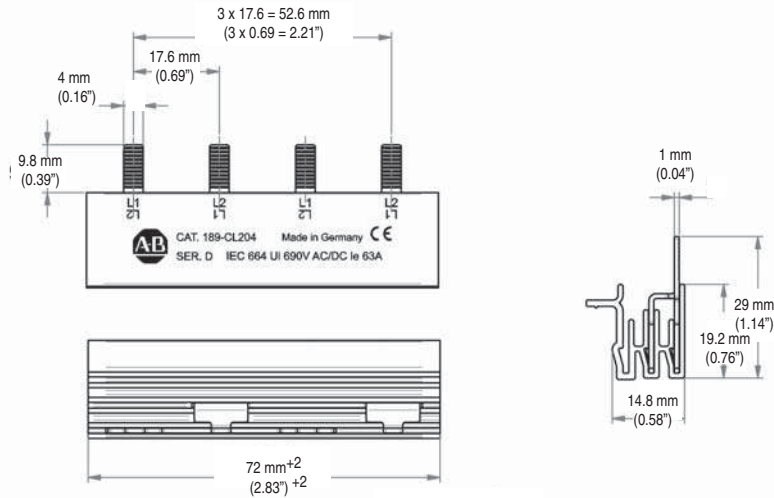

189-CL204

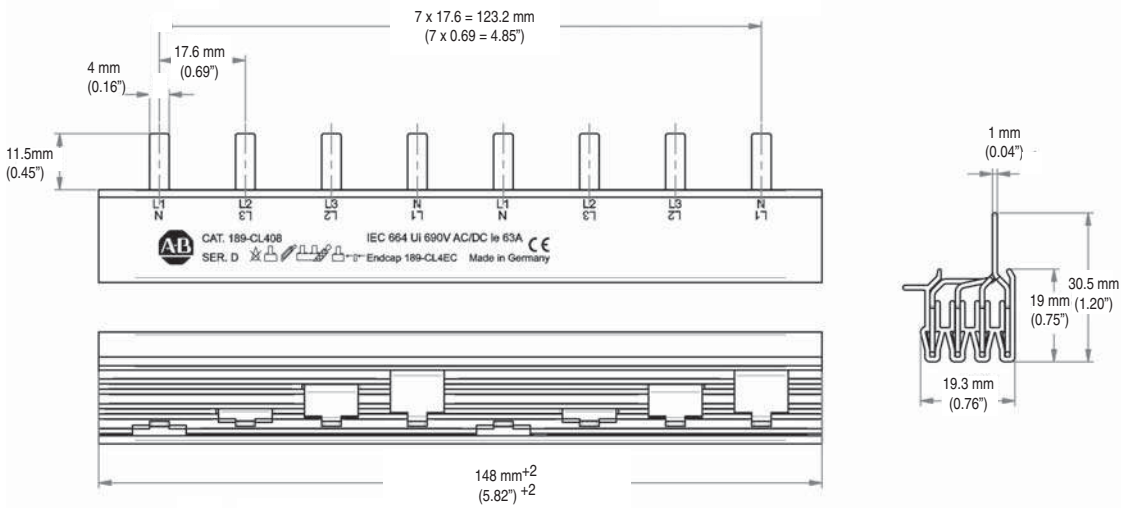

189-CL408

Bus Bar Accessory Approximate Dimensions

Note: Dimensions are shown in millimeters. Dimensions are not intended for manufacturing purposes.

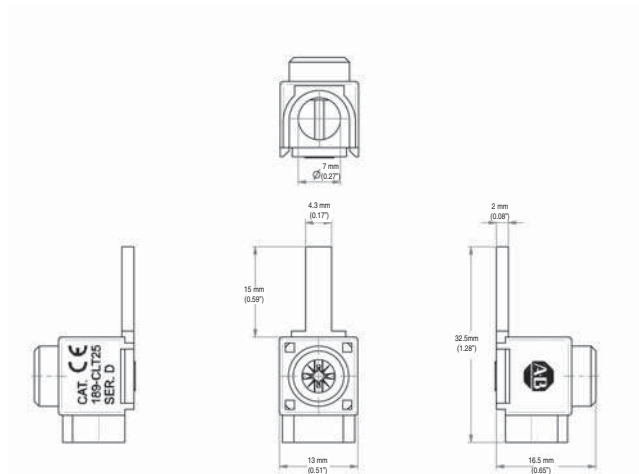

189-CLT25

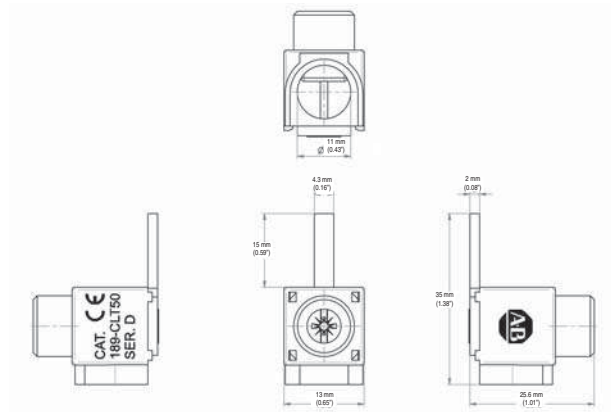

189-CLT50

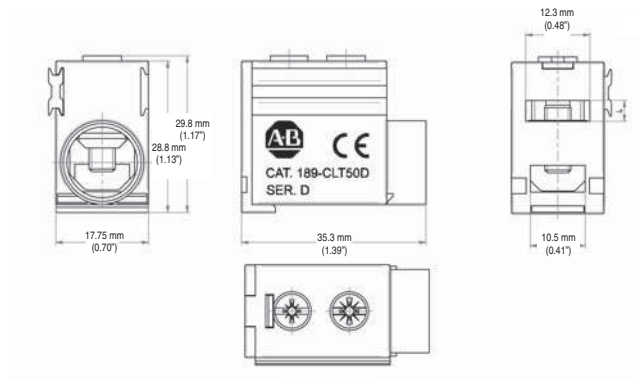

189-CLT50D

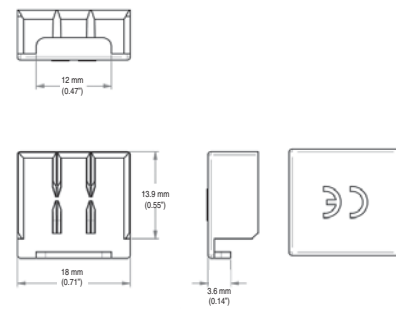

189-CL3EC

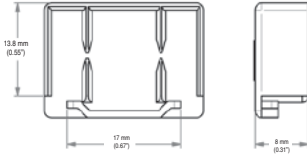
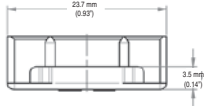

189-CL4EC

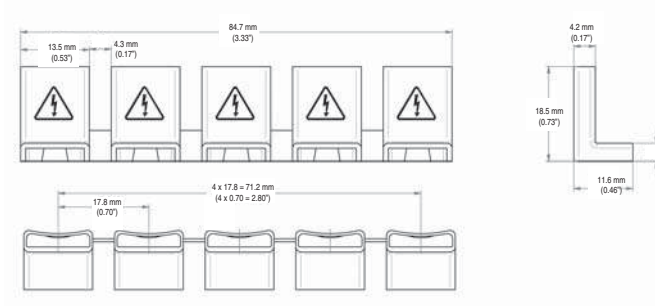

189-CLPS

1692 Specifications

Electrical Ratings	
Voltage	24V DC (18...30V DC)
Output current	1 A...12 A, select devices – NEC Class 2
Output ratings	Isolated safety extra-low voltage (SELV)
Environmental	
Operating temperature	-25...+70 °C (-13...158 °F) (non-condensing)
Storage temperature	-40 °C...+85 °C (-40...185 °F)
Humidity	5...95% (non-condensing)
Degree of pollution	2
Construction	
Terminal wire gauge	24...10 AWG (0.2...4mm ²)
Termination type	Screw
Dimensions in. (mm)	1.77 x 2.95 x 3.58 (45 x 75 x 91)
Weight lb. (g)	0.26 (120)

Approximate Dimensions

Note: Dimensions are shown in millimeters (inches). Dimensions are not intended for manufacturing purposes.

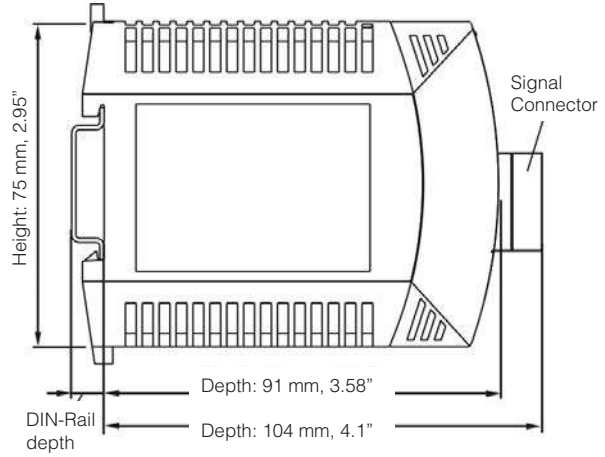
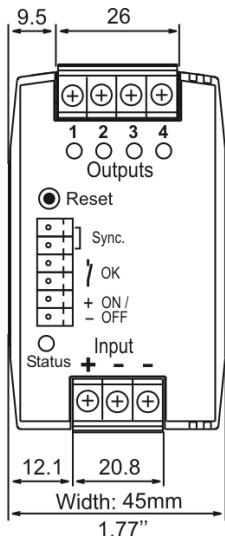

1492-MC Specifications

Electrical Ratings	
Rated voltage	See rated voltage tables
Continuous current rating @ 40°C (104°F)	10, 15, 20, 25, 30, 35, 40, 45, 50, 55, 60, 70, 80, 90, 100 A
Rated short circuit capability	See interrupting capacity tables
Environmental	
Operating temperature	0...60 °C (32...140 °F) (non-condensing)
Shipment and short term storage limits	-40 °C...+80 °C (-40...176 °F)
Degree of protection	1/2 in. wide circuit breakers are finger safe from front per IEC. Terminal covers available for 1 in. wide circuit breaker.
Mechanical	
Mounting	DIN rail
Wire size	See terminal table
Terminal torque	
Recommended wire strip length	

1492-MCA/MCB Thermal Magnetic Rated Voltage and Interrupting Capacity

Cat. No.	Rated Voltage		Interrupting Capacity (rms Symmetrical Amperes)	
	[V AC]	[V DC] ★	AC Rating [kA]	DC Rating ★ [kA]
1492-MCAA1xx	120/240	24, 48, 62.5	10	3
1492-MCAA2xx				
1492-MCAA2Hxx	240	24, 48, 62.5		3
1492-MCAA3xx				
1492-MCBA1xx	120/240	—		—
1492-MCBA2xx				
1492-MCBA2Hxx	240	—		—
1492-MCBA3xx				

★ Rating as supplementary protector.

1492-MCE/MCG Ground Sensing Rated Voltage and Interrupting Capacity

Cat. No.	Rated Voltage	Interrupting Capacity (rms Symmetrical Amperes)
	[V AC]	
1492-MCEA1xx	120	10
1492-MCEA2xx	120/240 ‡	
1492-MCGAT1xx	120	
1492-MCGAT2xx	120/240 ‡	

‡ These devices are for grounded neutral 240V wye systems only.

Application Information

Selection of a Bul. 1492-MC circuit breaker with appropriate circuit protection includes consideration of:

- Circuit voltage
- Circuit frequency
- Available short circuit current
- Continuous current rating
- Application considerations
- Special operating conditions

The following discussion is based upon National Electric Code and UL requirements. Similar considerations are appropriate for Canadian applications.

Circuit Voltage

Bul. 1492-MC circuit breakers are rated by voltage class. Applications should not exceed the listed voltage range (see Table 1).

Circuit Frequency

Bul. 1492-MC circuit breakers may be applied to frequencies from DC up to 60 Hz without derating. For applications above 60...400 Hz, contact Rockwell Automation with specific application information for the derating of the circuit breakers.

Available Short Circuit Current

Bul. 1492-MC circuit breakers should only be applied in those applications in which the available short-circuit (or fault) current is less than or equal to the interrupting rating shown in the Voltage and Interrupting Ratings table.

Continuous Current Rating

Bul. 1492-MC circuit breakers are rated in RMS amperes at a 40 °C (104 °F) ambient temperature per UL 489 (CSA 22.2 No. 5.1). This temperature is the ambient temperature external to an industrial enclosure. If a circuit breaker is applied in a temperature that exceeds the 40 °C (104 °F) ambient, then the circuit breaker should be derated. Contact your local Rockwell Automation sales office or Allen-Bradley distributor for derating information.

Application Considerations

The selection of a specific ampere rating for a specific application is dependent on the type of load and duty cycle and is governed by the National Electric Code (Canadian Electric Code) and UL/CSA. In general the codes require that overcurrent protection is at the current supply and at points where wire sizes are reduced. In addition the codes state that conductors be protected according to their current carrying capacity. There are specific situations that require application

consideration, such as motor circuit, and guidelines for the selection for transformer protection.

Bulletin 1492-MC circuit breakers are "non-100% rated" as defined by UL 489 Part 7.1.4.2. As such the circuit breaker's rating should be loaded to no more than 80%, if used with continuous loads.

Branch Circuits:

Bulletin 1492-MC circuit breakers may be used to protect branch circuits. A branch circuit is the wiring portion of a system extending beyond the final overcurrent device protecting the circuit.

Guidelines established in NEC, CEC, UL, and CSA should be used to determine the specific device. The examples on page , also apply to the 1492-MC devices.

Coordinated Overcurrent Protection

Where an orderly shutdown is required to minimize the hazards to personnel and equipment, a system of coordination based upon the faulted or overloaded circuit is isolated by selective operation of only the overcurrent protective device closest to the overcurrent condition.

The user should select devices that meet this requirement.

References: NEC 240.12. Also see CEC.

Self Test Capability (GFCI only)

Per UL 943 (5.16 / 6.30), GFCI devices have built-in self test capability. The self test is an internal, automated function running in the background. For more information please refer to UL 943 standard.

Tripping Characteristics

Time Current Curve – 1-Pole Circuit Breaker

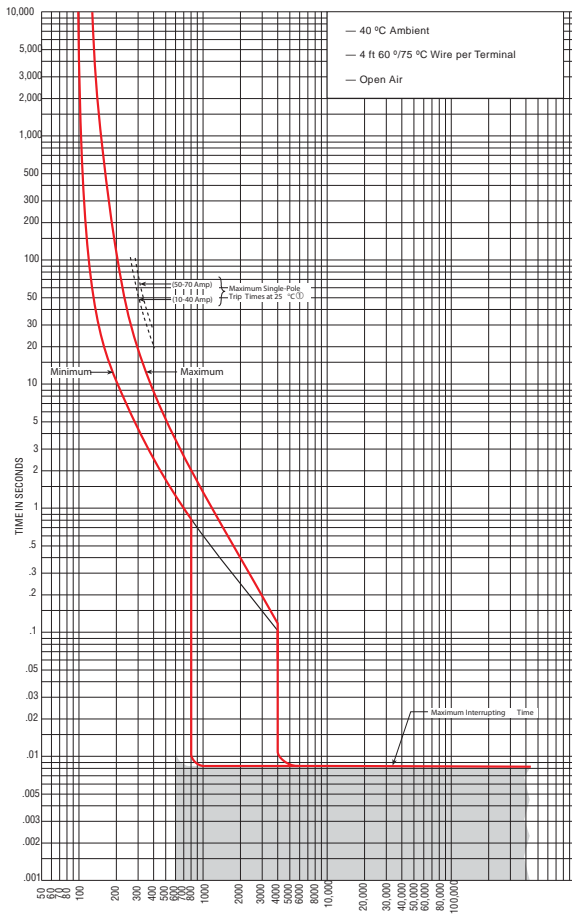

Time Current Curve – 2-Pole Circuit Breakers

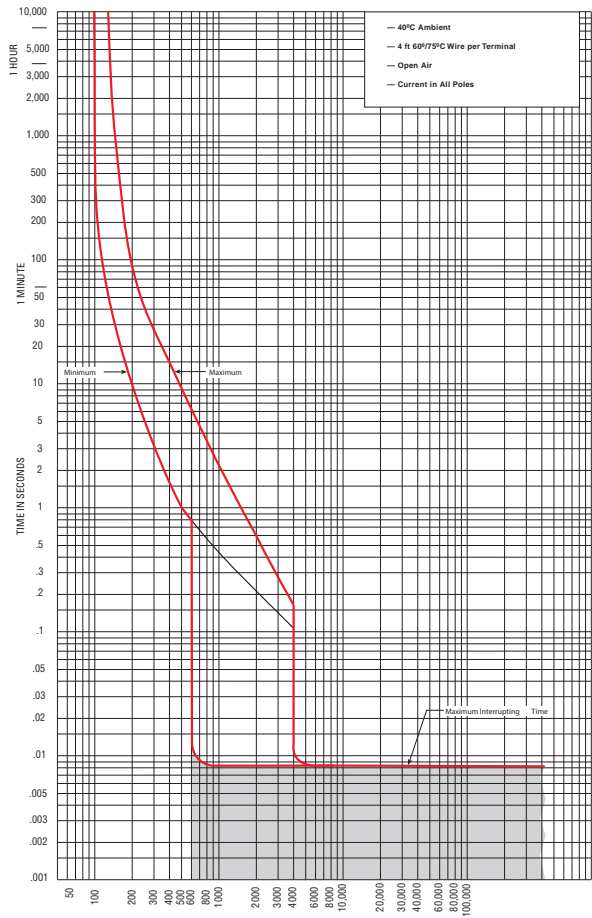

Tripping Characteristics

Time Current Curve – 3-Pole Circuit Breakers

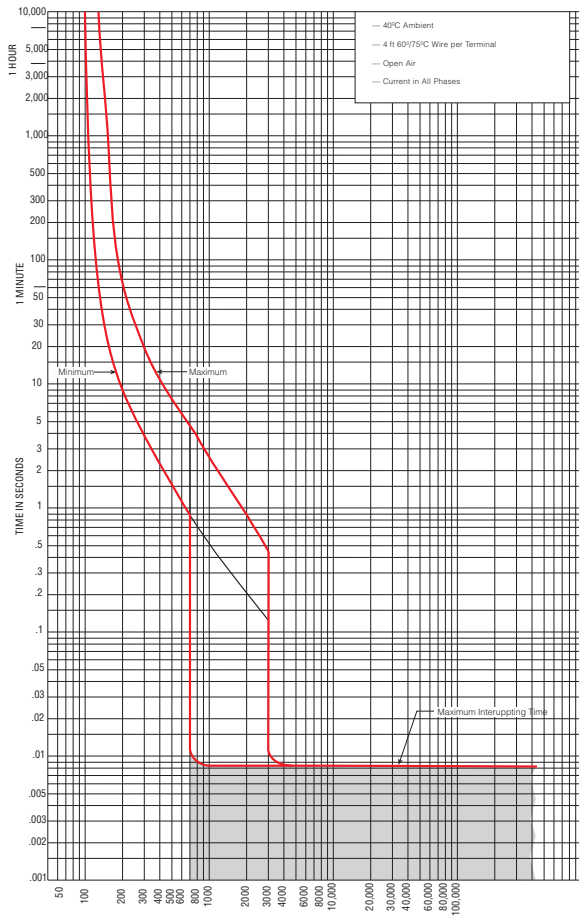

Approximate Dimensions

Note: Dimensions are shown in inches (mm). Dimensions are not intended for manufacturing purposes.

1492-MCAA

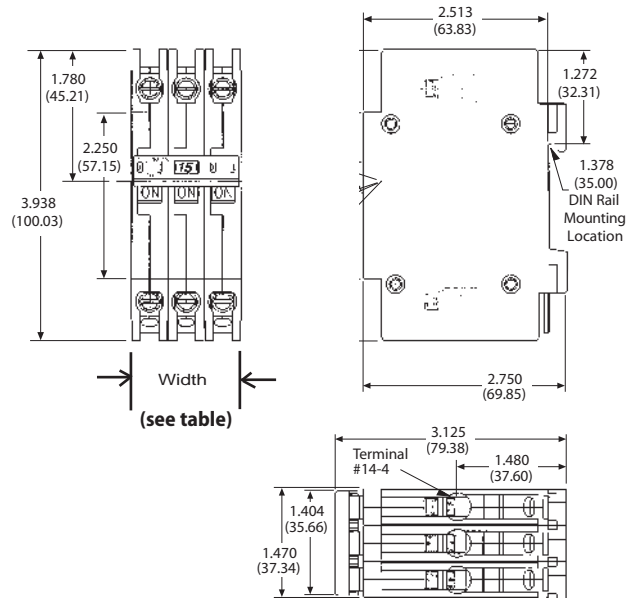

1-, 2-, 3-Pole (3-Pole shown)

1492-MCBA

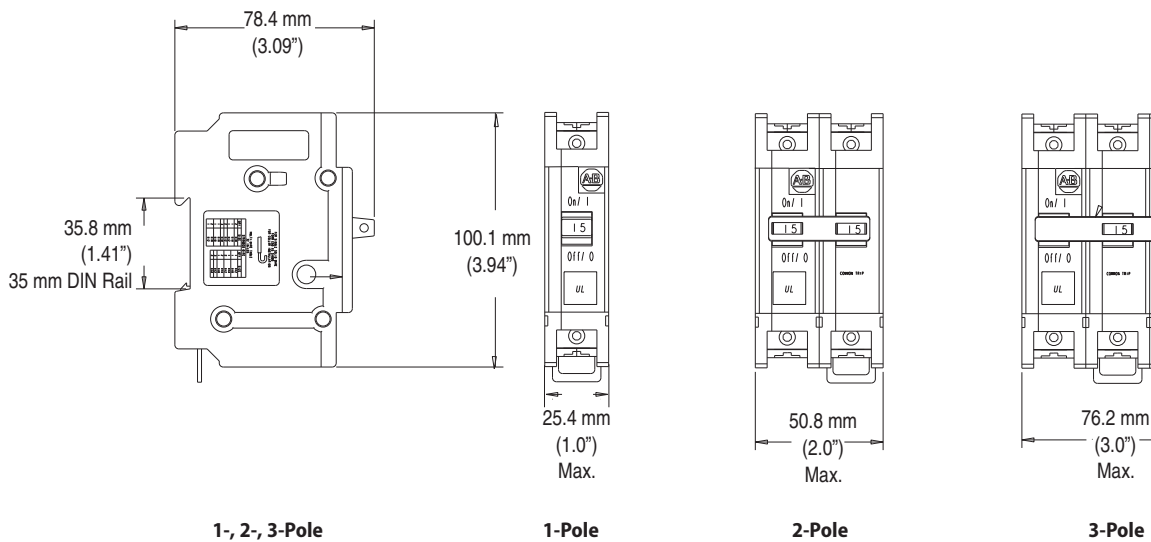

1-, 2-, 3-Pole

1-Pole

2-Pole

3-Pole

Approximate Dimensions

Note: Dimensions are shown in inches. Dimensions are not intended for manufacturing purposes.

1492-MCE/1492-MCG

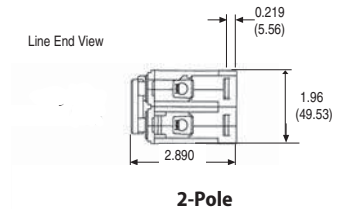
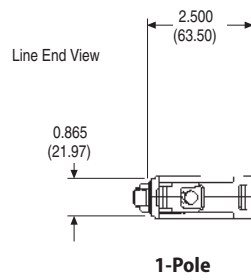
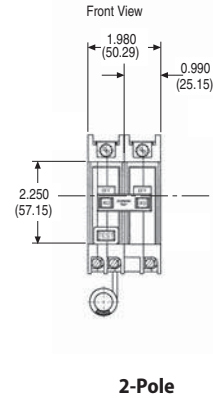
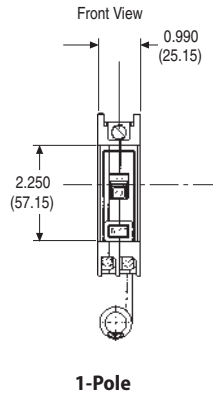
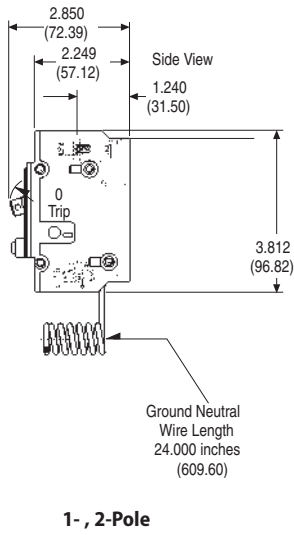

1492-GH/-GS Specifications

	1492-GH	1492-GS		
	1-Pole	1-Pole	2-Pole	3-Pole
UL/CSA	200 A (Not to exceed 100 x rated A)	0.2...16 A 18...25 A	5 kA C1 (2 kA C1 for 65V DC — 1-pole) 2 kA C1	
IEC/EN 60934 (CBE)	—	0.2...5 A 6...25 A	400 A 800 A	
Maximum voltage ratings	250V AC 50/60 Hz 65V DC	480Y/277V AC 50/60 Hz 65V DC		
Temperature range	-40...+149 °F (-40...+65 °C) non-condensing			
Operating life	6000 operations @ rated current			
Housing material	Glass-filled Polyamide 6.6			
Shock	25 G, 11 ms duration			
Vibration	5 G (10...500 Hz)			
Dielectric strength	1500V AC	1600V AC		
Insulation resistance	100 M Ω @ 500V DC			
Terminal type	Tubular screw with self-lifting box lug			
Wire size	#22...10 AWG			
Recommended wire strip length	0.44 in. (11.2 mm)	Main terminal — 0.51 in. (13 mm) aux terminal — 0.41 in. (10.4 mm)		
Terminal torque	1.3...1.4 N•m (10...12 lb•in)	0.656 N•m (5 lb•in)		
N.O. auxiliary contact rating	—	1.0 A AC or DC (resistive load)		

Approximate Dimensions

Note: Dimensions are shown in inches (mm). Dimensions are not intended for manufacturing purposes.

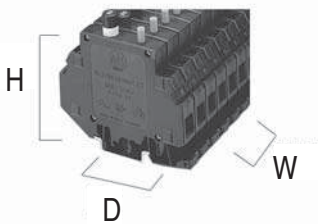

	1492-GH	1492-GS		
	1-Pole	1-Pole	2-Pole	3-Pole
Height	3.15 in. (80 mm)	3.15 in. (80 mm)		
Depth	2.89 in. (73.4 mm)	3.48 in. (88.5 mm)		
Width	0.49 in. (12.4 mm)	0.49 in. (12.5 mm)	0.98 in. (25 mm)	1.47 in. (37.5 mm)

Application Information

UL 1077, CSA C22.2 #235

In North America, miniature circuit breakers are recognized as supplementary protectors and are intended for use as overcurrent protection within an appliance or other electrical equipment where branch circuit protection is already provided or not required. Internationally, these products are rated to IEC standards as circuit breakers for equipment (CBE).

Selection Information

High-density supplementary protector/miniature circuit breaker applications include, but are not limited to, the protection of test equipment, control instrumentation, solenoids, and power supplies. The wide range of current values and the use of a thermal magnetic trip system allows for a variety of applications where a very accurate and compact breaker is required.

To select a miniature circuit breaker, use the following procedure:

1. Determine the inrush correction factor from the following table.

Inrush Ratio	1:1 to 1:4	1:5	1:6	1:7	1:8
Factor	1.3	1.4	1.5	1.6	1.7

Note: For resistive loads use an inrush correction factor of 1.0.

2. Determine the temperature correction factor from the following table.

Ambient Temperature	70 °F (21.1 °C)	100 °F (37.8 °C)	120 °F (48.9 °C)	140 °F (60 °C)	160 °F (71.1 °C)	180 °F (82.2 °C)	200 °F (93.3 °C)
Factor	1.0	1.1	1.2	1.3	1.4	1.5	1.6

3. Determine the sealed current of the load being protected.
4. Multiply the sealed current by the two correction factors and select the closest higher ampere rating.

Example — For a solenoid with sealed current of 0.5 A, an inrush ratio of 1:8, and an ambient temperature of +110 °F, ($0.5 \times 1.7 \times 1.15 = 0.9775$), select the 1.0 A miniature circuit breaker. Tripping time of the miniature circuit breaker is determined from the table below. Divide the miniature circuit breaker value by the temperature correction factor from the Ambient Temperature Correction Table to determine the actual rated current referenced in the table below.

Percent Rated Current	100%	200%	300%	400%	500%	600%	1000%	2000% Greater
Tripping Times (Seconds)	No Trip	10...40	3...18	1.5...9	0.8...6	0.003...4	0.009...2	Max. 0.02

Note: When several breakers are rail mounted adjacent to each other, the no-trip current will be 80% of rated current at 70 °F (21.1 °C).

Using selection tables, select Bulletin 1492-GH/GS that allows full load current nearest without exceeding application current. Also, check that inrush current is less than trip range of 6...10 *I_n*.

Tripping Characteristics

Time Current Curve –1492-GH

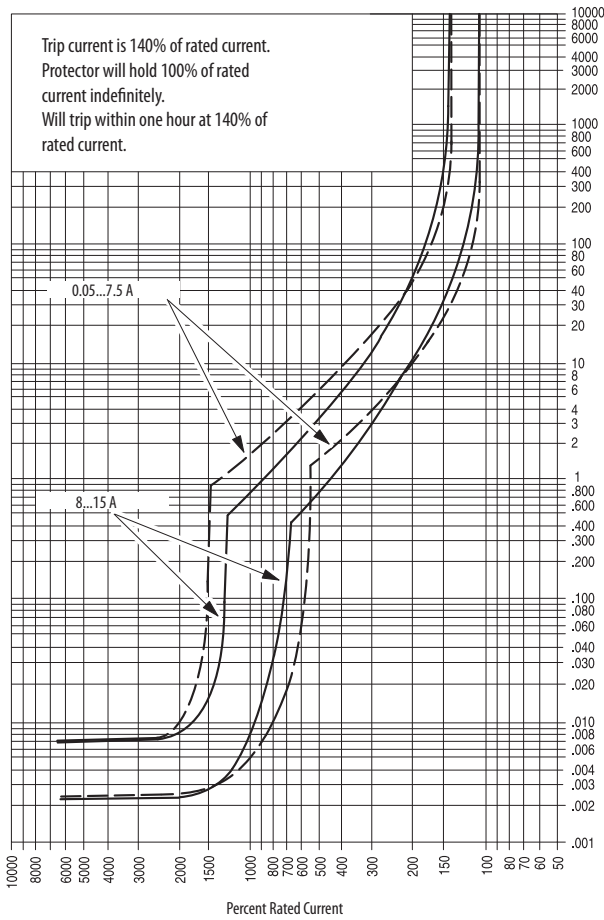

Time Current Curve –1492-GS

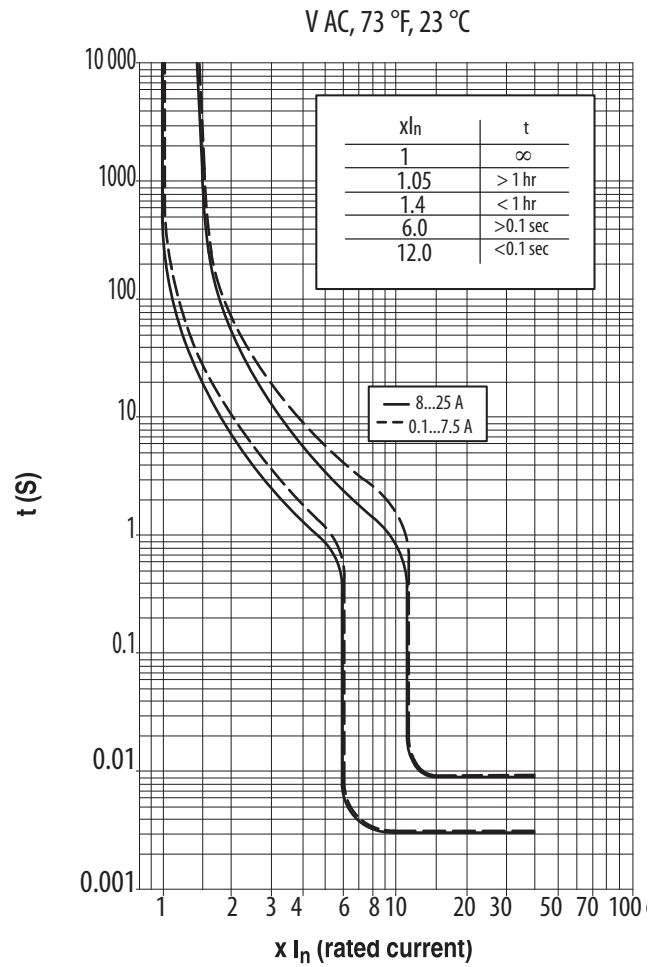

Note: When several breakers are rail mounted adjacent to each other, the no-trip current will be 80% of rated current at 70 °F (21.1 °C).

Notes

1492-FB Specifications

Product Type (n = number of poles)	M	CC	J30	J60
		1492-FBnM30 "B" 1492-FB1M30-D1 "B" 1492-FBnM30-L "B"	1492-FBnCC30 "B" 1492-FB1CC30-D1 "B" 1492-FBnCC30-L "B"	1492-FBnJ30 "B" 1492-FBnJ30-L "B"
For Fuse Type:	Midget 13/32" x 1-1/2" (10 x 38 mm)	Class CC	Class J	
Maximum voltage AC/DC	600V, 690V(IEC)	600V	600V	
Maximum current	30 A, 32 A (IEC)	30 A	30 A	60 A
Maximum current withstand (UL/CSA)	Fuse dependent 50 kA max UL	200 kA sym	200 kA sym	
Operating temperature range	-4...+130 °F, -20...+55 °C			
Conductor material	Copper, stranded			
Conductor strip length	0.43 in. (11 mm)		0.79 in. (20 mm)	
Conductor range	1 wire per terminal	#18...4 AWG (0.75...25 mm ²)	#18...1 AWG (0.75...50 mm ²)	#14...1 AWG (2.5...50 mm ²)
	2 wires ★ per terminal	#18...8 AWG (0.75...10 mm ²)	#18...6 AWG (0.75...16 mm ²)	#14...6 AWG (2.5...16 mm ²)
Terminal tightening torque	#18...8 AWG: 22 lb•in #6...4 AWG: 26 lb•in 0.75...25 mm ² : 2.5 N•m		35 lb•in (4 N•m)	

★ Both wires must be same size

Approximate Dimensions

Note: Dimensions are shown in inches (mm). Dimensions are not intended for manufacturing purposes.

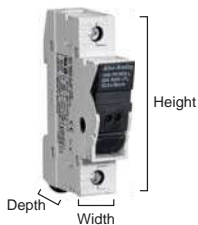

Dimension		For Midget Fuse	For Class CC Fuse	For Class J Fuse	
		30 A	30 A	30 A	60 A
Height		3.19 in. (81 mm)	3.19 in. (81 mm)	4.65 in. (118 mm)	4.65 in. (118 mm)
Depth		2.51 in. (64 mm)	2.51 in. (64 mm)	2.76 in. (70 mm)	3.23 in. (82 mm)
Width	1-Pole	0.71 in. (18 mm)	0.71 in. (18 mm)	1.41 in. (36 mm)	1.57 in. (40 mm)
	2-Pole	1.41 in. (36 mm)	1.41 in. (36 mm)	2.83 in. (72 mm)	3.15 in. (80 mm)
	3-Pole	2.13 in. (54 mm)	2.13 in. (54 mm)	4.25 in. (108 mm)	4.72 in. (120 mm)

Important User Information

Read this document and the documents listed in the additional resources section about installation, configuration, and operation of this equipment before you install, configure, operate, or maintain this product. Users are required to familiarize themselves with installation and wiring instructions in addition to requirements of all applicable codes, laws, and standards.

Activities including installation, adjustments, putting into service, use, assembly, disassembly, and maintenance are required to be carried out by suitably trained personnel in accordance with applicable code of practice.

If this equipment is used in a manner not specified by the manufacturer, the protection provided by the equipment may be impaired.

In no event will Rockwell Automation, Inc. be responsible or liable for indirect or consequential damages resulting from the use or application of this equipment.

The examples and diagrams in this manual are included solely for illustrative purposes. Because of the many variables and requirements associated with any particular installation, Rockwell Automation, Inc. cannot assume responsibility or liability for actual use based on the examples and diagrams.

No patent liability is assumed by Rockwell Automation, Inc. with respect to use of information, circuits, equipment, or software described in this manual.

Reproduction of the contents of this manual, in whole or in part, without written permission of Rockwell Automation, Inc., is prohibited.

Documentation Feedback

Your comments will help us serve your documentation needs better. If you have any suggestions on how to improve this document, complete this form, publication [RA-DU002](#), available at <http://www.rockwellautomation.com/literature/>.

Allen-Bradley, Rockwell Software, Rockwell Automation, and LISTEN. THINK. SOLVE are trademarks of Rockwell Automation, Inc.
Trademarks not belonging to Rockwell Automation are property of their respective companies.

Rockwell Otomasyon Ticaret A.Ş., Kar Plaza İş Merkezi E Blok Kat:6 34752 İçerenköy, İstanbul, Tel: +90 (216) 5698400

www.rockwellautomation.com

Power, Control and Information Solutions Headquarters

Americas: Rockwell Automation, 1201 South Second Street, Milwaukee, WI 53204-2496 USA, Tel: (1) 414.382.2000, Fax: (1) 414.382.4444
Europe/Middle East/Africa: Rockwell Automation NV, Pegasus Park, De Kleetlaan 12a, 1831 Diegem, Belgium, Tel: (32) 2 663 0600, Fax: (32) 2 663 0640
Asia Pacific: Rockwell Automation, Level 14, Core F, Cyberport 3, 100 Cyberport Road, Hong Kong, Tel: (852) 2887 4788, Fax: (852) 2508 1846

Publication 1492-TD014B-EN-P - February 2016

Supersedes Publication 1492-TD014A-EN-P - August 2014

Copyright © 2016 Rockwell Automation, Inc. All rights reserved. Printed in the U.S.A.