

Documentation | EN

# EP3204-0002 and EP3314-0002

EtherCAT Box Modules for Pt100 (RTD) and for thermocouples





# Table of contents

<b>1 Foreword .....</b>	<b>5</b>
1.1 Notes on the documentation.....	5
1.2 Safety instructions .....	6
1.3 Documentation issue status .....	7
<b>2 EtherCAT Box - Introduction .....</b>	<b>9</b>
<b>3 Module overview.....</b>	<b>11</b>
<b>4 EP3204-0002.....</b>	<b>12</b>
4.1 Introduction.....	12
4.2 Technical data .....	13
4.3 Process image.....	15
4.4 Scope of supply .....	15
<b>5 EP3314-0002.....</b>	<b>16</b>
5.1 Introduction.....	16
5.2 Technical data .....	17
5.3 Process image.....	19
5.4 Scope of supply .....	20
5.5 Basics of thermocouple technology .....	21
<b>6 Mounting and connection.....</b>	<b>29</b>
6.1 Mounting.....	29
6.1.1 Dimensions .....	29
6.1.2 Fixing .....	30
6.1.3 Tightening torques for plug connectors .....	30
6.2 Connection .....	31
6.2.1 Supply voltages .....	31
6.2.2 EtherCAT .....	34
6.2.3 Signal connection .....	36
6.3 UL Requirements.....	41
6.4 ATEX notes .....	42
6.4.1 ATEX - Special conditions .....	42
6.4.2 BG2000 - EtherCAT Box protection enclosures .....	43
6.4.3 ATEX Documentation .....	44
<b>7 Commissioning/Configuration .....</b>	<b>45</b>
7.1 Integration in TwinCAT .....	45
7.2 EP3204 – Data stream and calculation of the process data.....	45
7.2.1 Vendor calibration.....	45
7.2.2 User calibration and linearization.....	49
7.2.3 Scaling, limits and formatting.....	50
7.2.4 Summary .....	51
7.2.5 Two-point user calibration.....	52
7.3 EP3204 - object overview .....	54
7.4 EP3204 - object description and parameterization.....	60
7.4.1 Objects to be parameterized during commissioning.....	60
7.4.2 Objects for regular operation .....	65

7.4.3	Standard objects (0x1000-0x1FFF) .....	66
7.4.4	Profile-specific objects (0x6000-0xFFFF) .....	69
7.5	EP3314 - Settings .....	74
7.5.1	Cold junction compensation .....	74
7.5.2	Presentation, index 0x80n0:02 .....	76
7.5.3	Siemens bits, index 0x80n0:05 .....	77
7.5.4	Underrange, Overrange .....	77
7.5.5	Filter .....	77
7.5.6	Limit 1 and Limit 2 .....	77
7.5.7	Calibration .....	78
7.6	EP3314 - object overview .....	80
7.7	EP3314 - object description and parameterization .....	87
7.7.1	Objects to be parameterized during commissioning .....	87
7.7.2	Objects for regular operation .....	93
7.7.3	Standard objects (0x1000-0x1FFF) .....	93
7.7.4	Profile-specific objects (0x6000-0xFFFF) .....	99
7.8	Restoring the delivery state .....	104
7.9	Decommissioning .....	105
<b>8</b>	<b>Appendix .....</b>	<b>106</b>
8.1	General operating conditions .....	106
8.2	Accessories .....	107
8.3	Version identification of EtherCAT devices .....	108
8.3.1	Beckhoff Identification Code (BIC) .....	112
8.4	Support and Service .....	114

# 1 Foreword

## 1.1 Notes on the documentation

### Intended audience

This description is only intended for the use of trained specialists in control and automation engineering who are familiar with the applicable national standards.

It is essential that the documentation and the following notes and explanations are followed when installing and commissioning these components.

It is the duty of the technical personnel to use the documentation published at the respective time of each installation and commissioning.

The responsible staff must ensure that the application or use of the products described satisfy all the requirements for safety, including all the relevant laws, regulations, guidelines and standards.

### Disclaimer

The documentation has been prepared with care. The products described are, however, constantly under development.

We reserve the right to revise and change the documentation at any time and without prior announcement.

No claims for the modification of products that have already been supplied may be made on the basis of the data, diagrams and descriptions in this documentation.

### Trademarks

Beckhoff®, TwinCAT®, TwinCAT/BSD®, TC/BSD®, EtherCAT®, EtherCAT G®, EtherCAT G10®, EtherCAT P®, Safety over EtherCAT®, TwinSAFE®, XFC®, XTS® and XPlanar® are registered trademarks of and licensed by Beckhoff Automation GmbH. Other designations used in this publication may be trademarks whose use by third parties for their own purposes could violate the rights of the owners.

### Patent Pending

The EtherCAT Technology is covered, including but not limited to the following patent applications and patents: EP1590927, EP1789857, EP1456722, EP2137893, DE102015105702 with corresponding applications or registrations in various other countries.



EtherCAT® is registered trademark and patented technology, licensed by Beckhoff Automation GmbH, Germany.

### Copyright

© Beckhoff Automation GmbH & Co. KG, Germany.

The reproduction, distribution and utilization of this document as well as the communication of its contents to others without express authorization are prohibited.

Offenders will be held liable for the payment of damages. All rights reserved in the event of the grant of a patent, utility model or design.

## 1.2 Safety instructions

### Safety regulations

Please note the following safety instructions and explanations!  
Product-specific safety instructions can be found on following pages or in the areas mounting, wiring, commissioning etc.

### Exclusion of liability

All the components are supplied in particular hardware and software configurations appropriate for the application. Modifications to hardware or software configurations other than those described in the documentation are not permitted, and nullify the liability of Beckhoff Automation GmbH & Co. KG.

### Personnel qualification

This description is only intended for trained specialists in control, automation and drive engineering who are familiar with the applicable national standards.

### Description of instructions

In this documentation the following instructions are used.  
These instructions must be read carefully and followed without fail!

#### DANGER

##### Serious risk of injury!

Failure to follow this safety instruction directly endangers the life and health of persons.

#### WARNING

##### Risk of injury!

Failure to follow this safety instruction endangers the life and health of persons.

#### CAUTION

##### Personal injuries!

Failure to follow this safety instruction can lead to injuries to persons.

#### NOTE

##### Damage to environment/equipment or data loss

Failure to follow this instruction can lead to environmental damage, equipment damage or data loss.



##### Tip or pointer

This symbol indicates information that contributes to better understanding.

### 1.3 Documentation issue status

Version	Comment
2.5	<ul style="list-style-type: none"> <li>• Thermocouple connection updated</li> <li>• Activation of cold junction compensation added</li> <li>• Dimensions updated</li> <li>• UL requirements updated</li> </ul>
2.4	<ul style="list-style-type: none"> <li>• Terminology update</li> <li>• Structure update</li> </ul>
2.3	<ul style="list-style-type: none"> <li>• Chapter „EP3314 – Settings“ added</li> <li>• Chapter “Basics of thermocouple technology” updated</li> <li>• Structure update</li> </ul>
2.2	<ul style="list-style-type: none"> <li>• Object descriptions corrected</li> <li>• Structure update</li> </ul>
2.1.0	<ul style="list-style-type: none"> <li>• Chapter <i>EP3204 – Data stream and calculation of the process data</i> added</li> <li>• Update of chapter <i>Mounting and connection</i></li> <li>• Correction technical data in chapter <i>Power cables</i></li> <li>• Structural update</li> </ul>
2.0.1	<ul style="list-style-type: none"> <li>• EP3204-0002 - Technical data updated</li> </ul>
2.0.0	<ul style="list-style-type: none"> <li>• Migration</li> <li>• Structure update</li> </ul>
1.2.0	<ul style="list-style-type: none"> <li>• EP3204 - object description and parameterization updated</li> <li>• EP3314 - object description and parameterization updated</li> <li>• Foreword updated</li> <li>• Technical data updated</li> </ul>
1.1.0	<ul style="list-style-type: none"> <li>• Power Connection updated</li> </ul>
1.0.0	<ul style="list-style-type: none"> <li>• ATEX notes added</li> <li>• Technical data updated</li> <li>• Extended temperature range for activated modules documented</li> <li>• Overview of EtherCAT cables extended</li> <li>• Description of the power connection updated</li> <li>• Description of the status LEDs for the power supply added</li> </ul>
0.6	<ul style="list-style-type: none"> <li>• Object descriptions corrected</li> </ul>
0.5	<ul style="list-style-type: none"> <li>• First preliminary version</li> </ul>

## Firmware and hardware versions

This documentation refers to the firmware and hardware version that was applicable at the time the documentation was written.

The module features are continuously improved and developed further. Modules having earlier production statuses cannot have the same properties as modules with the latest status. However, existing properties are retained and are not changed, so that older modules can always be replaced with new ones.

Documentation Version	EP3204-0002		EP3314-0002	
	Firmware	Hardware	Firmware	Hardware
2.5	07	20	06	20
2.4	07	20	06	16
2.3	07	19	06	16
2.2	07	17	06	16
2.1.0	07	13	06	14
2.0.1	07	10	05	11
2.0.0	07	10	05	11
1.2.0	05	08	05	09
1.1.0	05	08	05	09
1.0.0	05	05	02	05
0.6	03	01	01	01
0.5	03	01	01	01

The firmware and hardware version (delivery state) can be found in the batch number (D-number) printed on the side of the EtherCAT Box.

### Syntax of the batch number (D-number)

D: WW YY FF HH

WW - week of production (calendar week)

YY - year of production

FF - firmware version

HH - hardware version

Example with D no. 29 10 02 01:

29 - week of production 29

10 - year of production 2010

02 - firmware version 02

01 - hardware version 01

Further information on this topic: [Version identification of EtherCAT devices \[► 108\]](#).



## 2 EtherCAT Box - Introduction

The EtherCAT system has been extended with EtherCAT Box modules with protection class IP 67. Through the integrated EtherCAT interface the modules can be connected directly to an EtherCAT network without an additional Coupler Box. The high-performance of EtherCAT is thus maintained into each module.

The extremely low dimensions of only 126 x 30 x 26.5 mm (h x w x d) are identical to those of the Fieldbus Box extension modules. They are thus particularly suitable for use where space is at a premium. The small mass of the EtherCAT modules facilitates applications with mobile I/O interface (e.g. on a robot arm). The EtherCAT connection is established via screened M8 connectors.

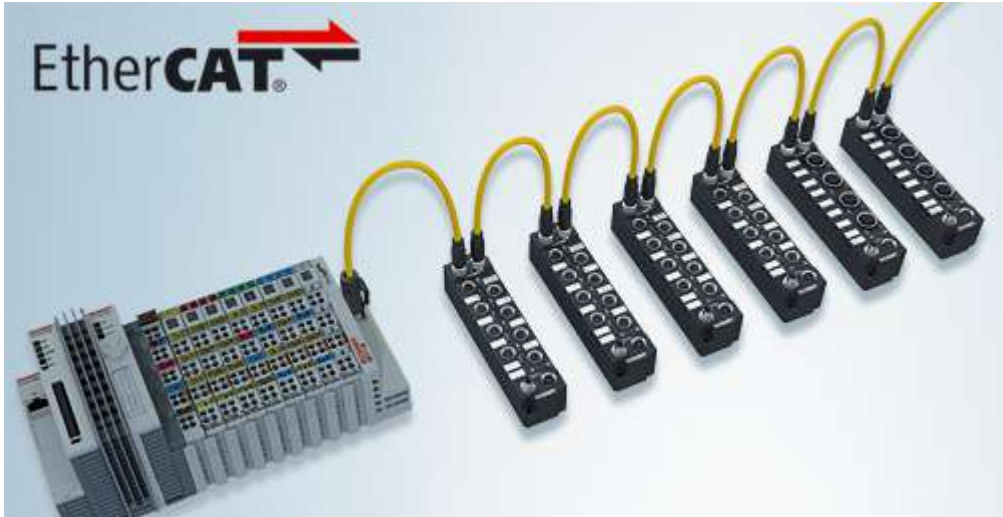

Fig. 1: EtherCAT Box Modules within an EtherCAT network

The robust design of the EtherCAT Box modules enables them to be used directly at the machine. Control cabinets and terminal boxes are now no longer required. The modules are fully sealed and therefore ideally prepared for wet, dirty or dusty conditions.

Pre-assembled cables significantly simplify EtherCAT and signal wiring. Very few wiring errors are made, so that commissioning is optimized. In addition to pre-assembled EtherCAT, power and sensor cables, field-configurable connectors and cables are available for maximum flexibility. Depending on the application, the sensors and actuators are connected through M8 or M12 connectors.

The EtherCAT modules cover the typical range of requirements for I/O signals with protection class IP67:

- digital inputs with different filters (3.0 ms or 10  $\mu$ s)
- digital outputs with 0.5 or 2 A output current
- analog inputs and outputs with 16 bit resolution
- Thermocouple and RTD inputs
- Stepper motor modules

XFC (eXtreme Fast Control Technology) modules, including inputs with time stamp, are also available.



Fig. 2: EtherCAT Box with M8 connections for sensors/actuators



Fig. 3: EtherCAT Box with M12 connections for sensors/actuators

---

**● Basic EtherCAT documentation**



You will find a detailed description of the EtherCAT system in the Basic System Documentation for EtherCAT, which is available for download from our website ([www.beckhoff.com](http://www.beckhoff.com)) under Downloads.

---

### 3 Module overview

#### Analog input modules, 24 VDC

Module	Number of inputs	Signal connection	Comment
EP3204-0002 [ <a href="#">▶ 12</a> ]	4	M12	Pt100 (RTD)
EP3314-0002 [ <a href="#">▶ 16</a> ]	4	M12	Thermocouples

## 4 EP3204-0002

### 4.1 Introduction

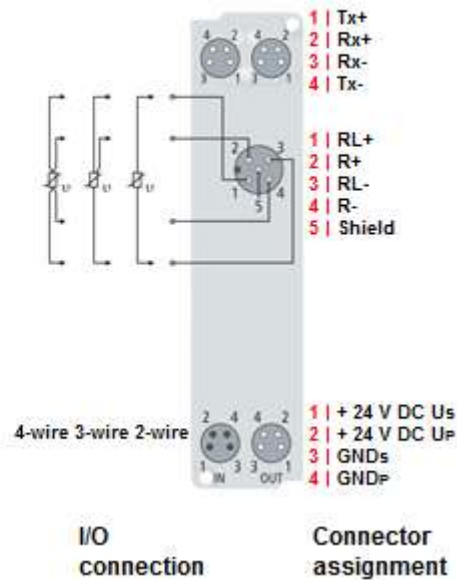
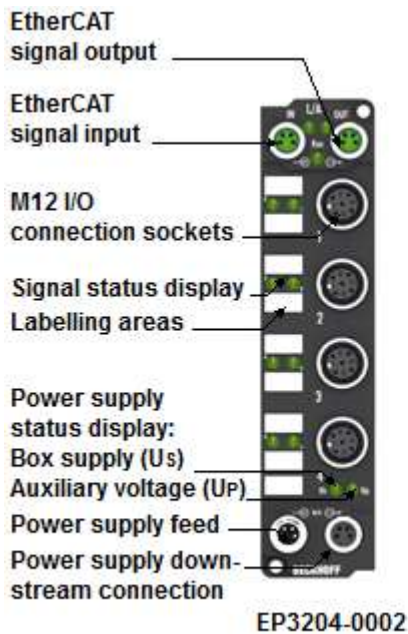

#### EtherCAT Box with four analog inputs for Pt100 (RTD)

The EP3204 EtherCAT Box with analog inputs enables direct connection of resistance sensors. The module circuit can operate sensors with 2-, 3- and 4-wire technology. Linearisation over the full temperature range is realized with the aid of a microprocessor. The temperature range can be selected freely. The module can also be used for simple resistance measurement, with the output in ohms. The module's standard settings are: Resolution 0.1°C in the temperature range of Pt100 sensors in 4-wire connection. Sensor malfunctions such as broken wires are indicated by error LEDs.

The module is quite versatile, but the default values are selected in such a way that in most cases it is not necessary to perform configuration. The input filter and associated conversion times can be set within a wide range, and several data output formats may be chosen. The inputs can, if required, be scaled differently, and automatic limit monitoring is also available. EtherCAT is used for parameterization purposes.

#### Quick links

[Technical data](#) [▶ 13]

[Process image](#) [▶ 15]

[Signal connections](#) [▶ 36]

[Calibration and scaling](#) [▶ 45]

## 4.2 Technical data

All values are typical values over the entire temperature range, unless stated otherwise.

EtherCAT	
Connection	2 x M8 socket, 4-pin, green
Electrical isolation	500 V

Supply voltages	
Connection	Input: M8 connector, 4-pin Downstream connection: M8 socket, 4-pin, black
$U_S$ nominal voltage	24 V <sub>DC</sub> (-15 % / +20 %)
$U_S$ sum current: $I_{S,sum}$	max. 4 A
Current consumption from $U_S$	120 mA
Rated voltage $U_P$	24 V <sub>DC</sub> (-15 % / +20 %)
$U_P$ sum current: $I_{P,sum}$	max. 4 A
Current consumption from $U_P$	None. $U_P$ is only forwarded.

RTD inputs	
Number	4
Connectors	4 x M12 socket
Sensor types	<ul style="list-style-type: none"> <li>Platinum RTD: Pt100, Pt200, Pt500, Pt1000</li> <li>Nickel RTD: Ni100, Ni120, Ni1000</li> <li>Resistance/potentiometer up to 4095 <math>\Omega</math></li> </ul>
Connection technology	<ul style="list-style-type: none"> <li>2-wire connection</li> <li>3-wire connection</li> <li>4-wire connection</li> </ul>
Electrical isolation	The measuring channels have a common isolated ground potential.
Measuring current RL+, RL-	Max. 0.5 mA, load-dependent
Measuring range	Platinum RTD: -200...+850 °C Nickel RTD: -60...+250 °C (Ni120: -60...+320 °C) Resistance: 0...4095 $\Omega$
Measuring error	max. $\pm 0.5$ K (Pt sensors in 4-wire connection)
Digital resolution	16 Bit
Value of an LSB	Temperature measurement: Standard: 0.1 °C High-precision: 0.01 °C Resistance measurement: Measuring range 1023 $\Omega$ : 1/64 $\Omega$ Measuring range 4095 $\Omega$ : 1/16 $\Omega$
Filter	Digital filter. Cut-off frequency parameterizable: 5 Hz ... 30 kHz..
Conversion time	2...800 ms, depending on the parameterization Default: approx. 85 ms
Diagnostics	<ul style="list-style-type: none"> <li>Open-circuit recognition</li> <li>Limit value monitoring</li> </ul>

<sup>1)</sup> This value corresponds to the current carrying capacity of the connections for the supply voltages.

Housing data	
Dimensions W x H x D	30 mm x 126 mm x 26.5 mm (without connectors)
Weight	approx. 165 g
Installation position	variable
Material	PA6 (polyamide)

Environmental conditions	
Ambient temperature during operation	-25...+60 °C -25...+55 °C according to cURus
Ambient temperature during storage	-40...+85 °C
Vibration resistance, shock resistance	conforms to EN 60068-2-6 / EN 60068-2-27 Additional checks [► 14]
EMC immunity / emission	conforms to EN 61000-6-2 / EN 61000-6-4
Protection class	IP65, IP66, IP67 (conforms to EN 60529)

Approvals	
Approvals	CE, cURus [► 41], ATEX [► 42]

### Additional checks

The boxes have been subjected to the following checks:

Verification	Explanation
Vibration	10 frequency sweeps in 3 axes
	5 Hz < f < 60 Hz displacement 0.35 mm, constant amplitude
	60.1 Hz < f < 500 Hz acceleration 5 g, constant amplitude
Shocks	1000 shocks in each direction, in 3 axes
	35 g, 11 ms

## 4.3 Process image

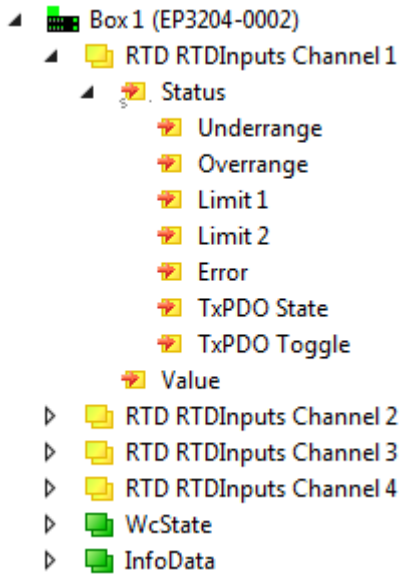

Fig. 4: RTD RTDInputs Channel 1

The data for the first analog channel can be found under **RTD RTDInputs Channel 1**.

### AI Standard Channel 2 to 4

The data of analog channels 2 to 4 have the same structure as those of the 1<sup>st</sup> channel.

## 4.4 Scope of supply

Make sure that the following components are included in the scope of delivery:

- 1x EtherCAT Box EP3204-0002
- 1x protective cap for supply voltage input, M8, transparent (pre-assembled)
- 1x protective cap for supply voltage output, M8, black (pre-assembled)
- 2x protective cap for EtherCAT socket, M8, green (pre-assembled)
- 10x labels, blank (1 strip of 10)

### **i** Pre-assembled protective caps do not ensure IP67 protection

Protective caps are pre-assembled at the factory to protect connectors during transport. They may not be tight enough to ensure IP67 protection.

Ensure that the protective caps are correctly seated to ensure IP67 protection.

## 5 EP3314-0002

### 5.1 Introduction

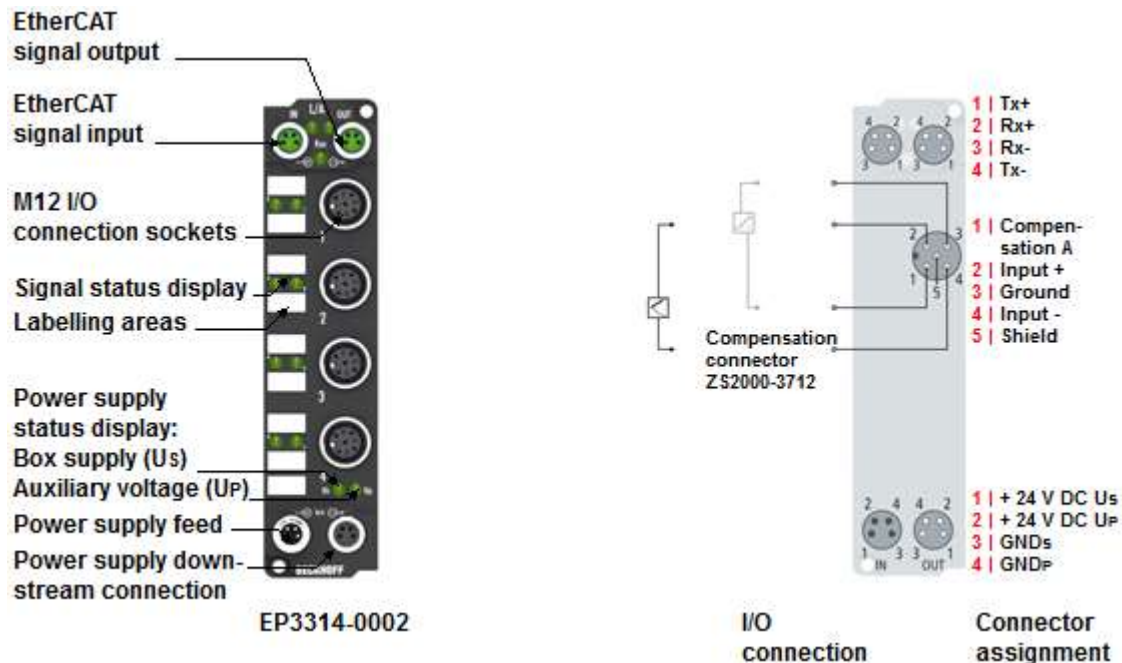

#### EtherCAT Box with four analog inputs for thermocouples

The EP3314 EtherCAT Box with analog inputs enables direct connection of four thermocouples. The module circuit can operate thermocouple sensors in a 2-wire configuration. Linearisation over the full temperature range is realized with the aid of a microprocessor. The temperature range can be selected freely. The error LEDs indicate a broken wire. Compensation for the cold junction is made through a temperature measurement in the connecting plugs. This means that standard extension leads can be connected. The EP3314 also enables millivolt measurement.

The module is quite versatile, but the default values are selected in such a way that in most cases it is not necessary to perform configuration. The input filter and associated conversion times can be set within a wide range, and several data output formats may be chosen. The inputs can, if required, be scaled differently, and automatic limit monitoring is also available. EtherCAT is used for parameterization purposes. The parameters are stored in the module. For temperature compensation a Pt1000 element is required. Beckhoff offers a plug connector with temperature compensation (ZS2000-3712).

#### Quick links

- [Technical data \[▶ 17\]](#)
- [Process image \[▶ 19\]](#)
- [Signal connection \[▶ 37\]](#)
- [Settings \[▶ 74\]](#)



## 5.2 Technical data

All values are typical values over the entire temperature range, unless stated otherwise.

EtherCAT	
Connection	2 x M8 socket, 4-pin, green
Electrical isolation	500 V

Supply voltages	
Connection	Input: M8 connector, 4-pin Downstream connection: M8 socket, 4-pin, black
$U_S$ nominal voltage	24 V <sub>DC</sub> (-15 % / +20 %)
$U_S$ sum current: $I_{S,sum}$	max. 4 A
Current consumption from $U_S$	120 mA
Rated voltage $U_P$	24 V <sub>DC</sub> (-15 % / +20 %)
$U_P$ sum current: $I_{P,sum}$	max. 4 A
Current consumption from $U_P$	None. $U_P$ is only forwarded.

Thermocouple inputs	
Number	4
Connector	4 x M12 socket
Cable length to thermocouple	max. 30 m
Sensor types	<ul style="list-style-type: none"> <li>• Thermocouples [► 18]</li> <li>• Sensors with a voltage output of up to <math>\pm 75</math> mV</li> </ul>
Electrical isolation	The measuring channels have a common isolated ground potential.
Measuring ranges	Thermocouples: depending on <u>type</u> [► 18]. Voltage measurement: $\pm 30$ mV, $\pm 60$ mV, $\pm 75$ mV
Measuring error	Thermocouple type K: max. $\pm 0.3$ %, relative to the full scale value
Digital resolution	16-bit
Value of an LSB	Thermocouple: 0.1 °C Voltage measurement: Measuring range 30 mV: 1 $\mu$ V Measuring range 60 mV: 2 $\mu$ V Measuring range 75 mV: 4 $\mu$ V
Filter	Digital filter. Filter frequency adjustable from 5 Hz ... 30 kHz
Conversion time	approx. 2.5 s to 20 ms, depending on configuration and filter setting. Default: approx. 250 ms
Diagnostics	<ul style="list-style-type: none"> <li>• Open-circuit recognition</li> <li>• Limit value monitoring</li> </ul>

<sup>1)</sup> This value corresponds to the current carrying capacity of the connections for the supply voltages.

Housing data	
Dimensions W x H x D	30 mm x 126 mm x 26.5 mm (without connectors)
Weight	approx. 165 g
Installation position	variable
Material	PA6 (polyamide)

Environmental conditions	
Ambient temperature during operation	-25...+60 °C -25...+55 °C according to cURus
Ambient temperature during storage	-40...+85 °C
Vibration resistance, shock resistance	conforms to EN 60068-2-6 / EN 60068-2-27 Additional checks [► 18]
EMC immunity / emission	conforms to EN 61000-6-2 / EN 61000-6-4
Protection class	IP65, IP66, IP67 (conforms to EN 60529)

Approvals	
Approvals	CE, cURus [► 41], ATEX [► 42]

### Additional checks

The boxes have been subjected to the following checks:

Verification	Explanation
Vibration	10 frequency sweeps in 3 axes
	5 Hz < f < 60 Hz displacement 0.35 mm, constant amplitude
	60.1 Hz < f < 500 Hz acceleration 5 g, constant amplitude
Shocks	1000 shocks in each direction, in 3 axes
	35 g, 11 ms

### Overview of suitable thermocouples

The following thermocouples are suitable for temperature measurement:

Type (according to EN60584-1)	Element	Implemented temperature range	Color coding (sheath - plus pole - minus pole)
B	Pt30%Rh-Pt6Rh	600°C to 1800°C	grey - grey - white
C *	W5%Re-W25%Re	0°C to 2320°C	n.d.
E	NiCr-CuNi	-100°C to 1000°C	violet - violet - white
J	Fe-CuNi	-100°C to 1200°C	black - black - white
K	NiCr-Ni	-200°C to 1370°C	green - green - white
L **	Fe-CuNi	0°C to 900°C	blue - red - blue
N	NiCrSi-NiSi	-100°C to 1300°C	pink - pink - white
R	Pt13%Rh-Pt	0°C to 1767°C	orange - orange - white
S	Pt10%Rh-Pt	0°C to 1760°C	orange - orange - white
T	Cu-CuNi	-200°C to 400°C	brown - brown - white
U **	Cu-CuNi	0°C to 600°C	brown - red - brown

\* not standardized according to EN60584-1

\*\* according to DIN 43710

## 5.3 Process image

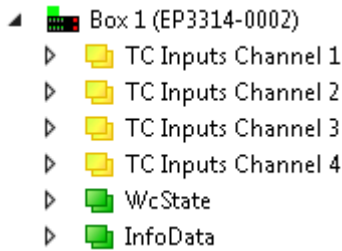
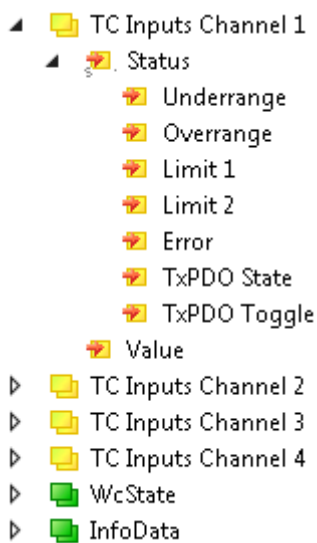

Fig. 5: Process image

### TC Inputs Channel 1



- Underrange  
Measurement is below range
- Overrange  
Measuring range exceeded
- Limit 1  
Status variable of the limit value monitoring  
0: The limit value monitoring is disabled  
1: The measured value is smaller than the limit value  
2: The measured value is greater than the limit value  
3: The measured value is exactly the same size as the limit value
- Limit 2  
Status variable of the limit value monitoring
- Error  
The current measured value "Value" is invalid.  
Possible reasons: Wire breakage, Underrange, Overrange
- TxPDO State  
If this bit is TRUE, the current measured value "Value" is invalid.
- TxPDO Toggle  
The box inverts this bit every time it updates the measured value "Value" in the process data.  
This allows the currently required conversion time to be derived.

Value  
The current measured value. Unit: 1/10 °C.

### TC Inputs Channel 2 bis 4

The process data objects of channels 2...4 have exactly the same structure as those of channel 1.

## 5.4 Scope of supply

Make sure that the following components are included in the scope of delivery:

- 1x EtherCAT Box EP3314-0002
- 1x protective cap for supply voltage input, M8, transparent (pre-assembled)
- 1x protective cap for supply voltage output, M8, black (pre-assembled)
- 2x protective cap for EtherCAT socket, M8, green (pre-assembled)
- 10x labels, blank (1 strip of 10)

---

### **● Pre-assembled protective caps do not ensure IP67 protection**

**i** Protective caps are pre-assembled at the factory to protect connectors during transport. They may not be tight enough to ensure IP67 protection.

Ensure that the protective caps are correctly seated to ensure IP67 protection.

---

## 5.5 Basics of thermocouple technology

### General term: "device"



This chapter is used in the documentation of several Beckhoff products. It is therefore written in general terms and uses the generic term "device" for the different device types such as terminal (EL/ELM/KL/ES series...), box (IP/EP/EPP series...), module (EJ/FM series...).

Thermocouples are temperature sensors. The application areas of thermocouples are very diverse due to their low cost, fast detection of temperature differences, wide temperature ranges, high temperature limits and availability in a wide range of types and sizes.

### Measuring principle and configuration

Temperature measurement with a thermocouple is based on the Seebeck effect, which was discovered in the 1820s by the German physicist Thomas Johann Seebeck. The Seebeck effect, also known as thermoelectric effect, describes a charge shift in a conductive material due to a temperature gradient along the conductor. The magnitude of the charge shift depends on the magnitude of the temperature difference and the respective conductor material.

In thermocouples this charge shift is used to generate a voltage. Two different conductor materials are connected at one end. This is the measuring point at which the temperature is to be determined. At the other end the conductors are not connected. This open end, where the transition to the measuring electronics is located, is the cold junction. A temperature difference occurs between the cold junction and the measuring point, which can be measured via the voltage between the conductors at the open end. The voltage depends on the conductor materials used and the temperature difference. It is in the range of a few mV.

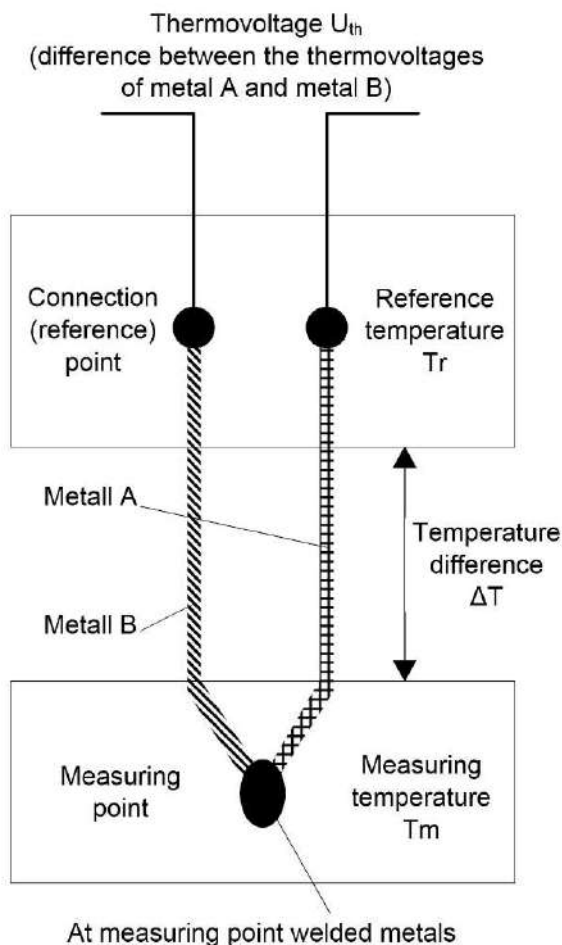

Fig. 6: Structure and principle of a thermocouple

If only one material were used for a thermocouple, the charge shift in both conductors would be identical, so that no potential difference between the two conductors at the open end could be measured.

The temperature measurement with thermocouples is therefore actually a voltage measurement, based on which a temperature can be determined from the known characteristic curve. In addition, the measuring procedure is not absolute but differential, since no absolute temperature (with the reference point 0 °C) is determined, but the temperature difference between the measuring point and the cold junction.

For the evaluation of thermocouples, measuring electronics are required that can evaluate small voltages in the mV range with sufficiently high resolution and accuracy. Thermocouples are active sensors, which means that no sensor supply is required to measure the temperature.

### Thermocouple types

There are different types of thermocouples, which consist of different combinations of conductor materials. Each material combination has specific properties and is suitable for certain applications. The different thermocouple types are distinguished by letters.

Due to the different material combinations, the different thermocouple types have different characteristic values. They differ in the temperature limits and the characteristic voltage/temperature curve. In order to be able to differentiate between the thermocouple types, the color codes for the sheath, the positive pole and the negative pole are defined in various standards.

The following table shows common thermocouple types with the specification of the materials used, the defined temperature ranges and the color coding.

Type (conforms to EN60584-1)	Element	Measuring range *		Average temperature coefficient	Voltage at FSV	Color coding (sheath - positive pole - negative pole)
		min	max			
B	Pt30%Rh-Pt6Rh	600 °C	1820 °C	6 µV/K	13.820 mV	grey - grey - white
C **	W5%Re-W25%Re	-18 °C	2316 °C	15 µV/K	37.070 mV	n.d.
E	NiCr-CuNi	-270 °C	1000 °C	65 µV/K	76.373 mV	violet - violet - white
J	Fe-CuNi	-210 °C	1200 °C	54 µV/K	69.553 mV	black - black - white
K	NiCr-Ni	-270 °C	1372 °C	42 µV/K	54.886 mV	green - green - white
L ***	Fe-CuNi	-200 °C	900 °C	54 µV/K	53.140 mV	blue - red - blue
N	NiCrSi-NiSi	-270 °C	1300 °C	27 µV/K	47.513 mV	pink - pink - white
R	Pt13%Rh-Pt	-50 °C	1768 °C	10 µV/K	21.101 mV	orange - orange - white
S	Pt10%Rh-Pt	-50 °C	1768 °C	10 µV/K	18.693 mV	orange - orange - white
T	Cu-CuNi	-270 °C	400 °C	40 µV/K	20.872 mV	brown - brown - white
U ***	Cu-CuNi	-200 °C	600 °C	40 µV/K	34.310 mV	brown - red - brown

\*The specified measuring range refers to the maximum possible measuring range of the specified thermocouple type. The possible measuring ranges of the thermocouple measuring devices may be limited. The possible measuring ranges of the thermocouple measuring devices are specified in the technical data in the documentation.

\*\*not standardized according to EN60584-1

\*\*\*conforms to DIN 43710

The thermocouple must be selected according to the operating conditions. Therefore, not only the uncertainty must be taken into account, but also the other properties of the different thermocouple types. For an application with small temperature fluctuations, it is advantageous to select a thermocouple type with a high thermovoltage per temperature change. In an application where the temperature to be measured is very high, it is important to observe the maximum operating temperature.

### Characteristic curve

Type-specific reference tables are available for determining the temperature difference to a measured thermovoltage. A simple conversion of the voltage into a temperature with a temperature coefficient, as is often approximated in resistance thermometers, is not possible because the relationship between voltage and temperature is clearly non-linear over the entire measuring range. The changing temperature coefficient results in a non-linear characteristic voltage/temperature curve. This characteristic curve is in turn dependent

on the thermocouple type, so that each type has its own non-linear characteristic voltage/temperature curve. As an example, the characteristic curves for typical thermocouple types are shown in the following diagram. The non-linearity is particularly evident in the temperature range below 0 °C.

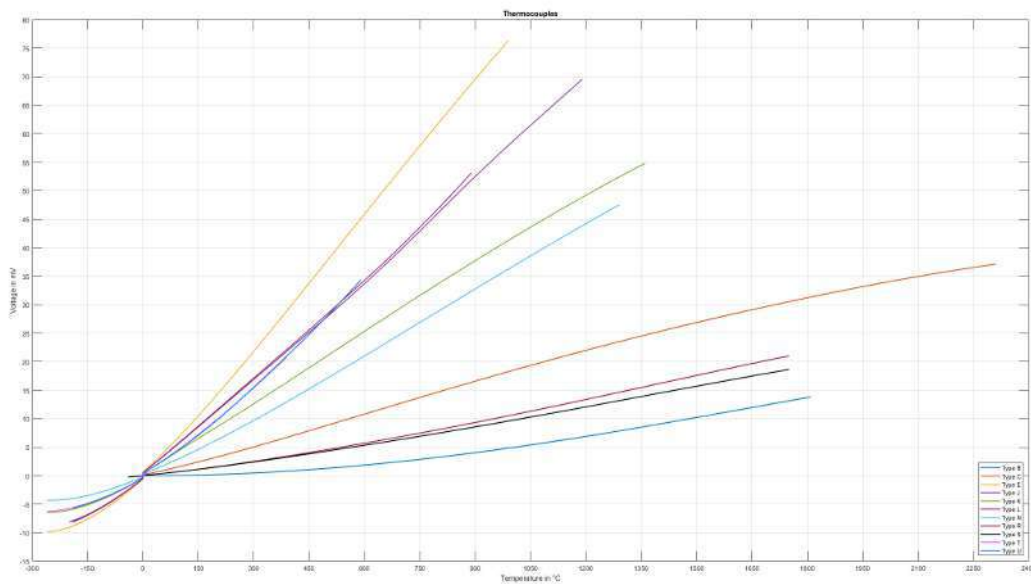

Fig. 7: Characteristic voltage/temperature curves of different thermocouple types

Thermocouples are subject to unavoidable and irreversible changes during practical application, which leads to ever-increasing measurement uncertainties over time. In other words: the measurement becomes more and more incorrect over time. These changes are also referred to as aging and depend on various influencing factors. Examples of these influences are mechanical and chemical stresses on the thermocouples. Mechanical stresses are deformations of the conductors, which change the crystal structure of the metals. This leads to incorrect thermovoltages. Chemical stresses are also changes in the crystal structure of the metals or oxidation, which change the thermal properties of the conductors, resulting in a change in the characteristic curve. This influence can be reduced by installation in gas-tight protection tubes.

**Pluggable connections**

Open wire ends or suitable thermocouple connectors can be used to connect thermocouples to measuring devices and evaluation electronics or to connect a thermocouple to thermo or compensating cables.

Ideally, the contacts of such a thermocouple connector are made of the material of the respective thermocouple. This results in a thermovoltage-free transition at the connection points. The plugs are color-coded depending on the type, e.g. type K is green. Labelling on the housing and different contact shapes are intended to avoid polarity reversal.



There are several common sizes: standard, mini, micro.

A special feature is the white connector, which is designed with normal copper contacts, almost like a normal non-thermocouple connector. This makes it universally applicable for all thermocouple types, although it has the disadvantage that it does not create a thermovoltage-free transition. Far more common than the white plug is the white "universal" socket on the measuring device. This allows any thermocouple plug to be plugged into the device. In the measuring device, the cold junction temperature must then be determined at this plug transition.

### Extensions and connection of thermocouples

In some cases it is useful to extend the thermocouple and thus to move the cold junction to a particular location, where the temperature can be kept constant or measured by simple means. For this purpose the thermocouple must be extended. This can be done with a thermo or compensation wire. Thermo cables are made of the same material as the thermocouple itself. Compensating cables, on the other hand, are usually made of cheaper materials with similar thermal properties. Both types are therefore suitable for extending a thermocouple to a remote cold junction. The wires for thermo and compensating cables are standardized by DIN 43713.

With compensating cables, care must be taken to ensure that the material used has similar thermal properties but not identical properties. The thermal properties only apply in a narrowly limited temperature range. At the transition from thermocouple to compensation wire, another thermocouple is created. This results in small thermovoltage distortions, which influence the measurement result. If the compensating cables are used outside the specified temperature range, the accuracy of the temperature measurement will be further affected and the measurement result will deteriorate.

For both thermal and compensation wires, there are two accuracy classes that indicate the limit deviations. These are defined in DIN 43722. When selecting the thermocouple extension, the resulting uncertainty should be considered and evaluated.

#### ● Sensor circuit

**i** Changing the sensor circuit through additional elements such as selector switches or multiplexers can affect the measuring accuracy. In such switches, small local thermovoltages can be generated which distort the measurement. If such components cannot be avoided in the application, their influence should be carefully examined.

#### ● Maximum cable length to the thermocouple

**i** Without additional protective measures, the maximum cable length from the measuring device to the thermocouple is 30 m. For longer cable lengths, suitable surge protection should be provided.

### Cold junction compensation / CJC

The correction of the thermovoltage value to determine the absolute temperature value is referred to as cold junction compensation. In order to determine an absolute temperature value that is as accurate as possible, the temperature at the cold junction must either be kept constant at a known value or measured continuously during the measurement with the smallest possible uncertainty. In some applications, the cold junction may be in an ice bath (0 °C), for example. In this case the temperature determined via the thermovoltage corresponds to both the temperature difference and the absolute temperature. In many applications, however, this option cannot be implemented, so that cold junction compensation is necessary.

As a cold junction in thermocouple evaluation with Bus Terminals, the cold junction temperature is measured at the transition from the thermocouple to the copper contacts. This value is measured continuously during operation in order to correct the determined values.

For IP67 modules and for EJ plug-in modules, the cold junction is located outside the module. For cold junction compensation, Pt1000 measuring resistors must be connected externally.

For IP67 modules Beckhoff offers the ZS2000-3712 connector with integrated Pt1000 measuring resistor for this purpose.

### Determination of the absolute temperature

Temperature measurement with a thermocouple is a differential temperature measurement, in which the temperature difference between the measuring point and the reference junction, also known as cold junction, is determined. To determine the absolute temperature at the measuring point, the measured thermovoltage must therefore be corrected by the thermovoltage at the cold junction. With the corrected thermovoltage, the



temperature at the measuring point can then be determined from suitable tables or characteristic curves. Due to the non-linearity of the characteristic curve, it is imperative that this calculation is carried out with the voltages and not with the temperature. Otherwise, there would be a significant error in the measurement.



### Difficulties in measuring temperature with thermocouples

- Linearization
- Cold junction compensation

In general, the absolute temperature is calculated using the following relationship:

$$U_{\text{measuring point}} = U_{\text{thermo}} + U_{\text{cold junction}}$$

$$T_{\text{measuring point}} = f(U_{\text{measuring point}})$$

In the following section, the absolute temperature is determined as an example based on correction of the thermovoltages and the temperature. The example calculation can be used to illustrate the error resulting from incorrect correction.

Sought:  $T_{\text{measuring point}}$

Known: Thermocouple type K,  $U_{\text{thermo}} = 24.255 \text{ mV}$ ,  $T_{\text{cold junction}} = 22 \text{ }^\circ\text{C}$

#### Option 1: Correction of thermovoltages – CORRECT

The thermovoltage at the cold junction  $U_{\text{cold junction}}$  must be determined based on the known temperature  $T_{\text{cold junction}}$  from the characteristic voltage/temperature curve or table for thermocouple type K:

$$U_{\text{cold junction}} = U(22 \text{ }^\circ\text{C}) = 0.879 \text{ mV}$$

The thermovoltage at the measuring point can then be determined with reference to  $0 \text{ }^\circ\text{C}$ :

$$U_{\text{measuring point}} = U_{\text{thermo}} + U_{\text{cold junction}} = 24.255 \text{ mV} + 0.879 \text{ mV} = 25.134 \text{ mV}$$

The corresponding temperature value can then be determined for thermocouple type K based on the determined thermovoltage from the characteristic voltage/temperature curve or table:

$$T_{\text{measuring point}} = T(25.134 \text{ mV}) \approx 605.5 \text{ }^\circ\text{C}$$

#### Option 2: Temperature correction – WRONG

In principle, the temperature difference between the cold junction and the measuring point  $T_{\text{thermo}}$  could be determined based on the known thermovoltage  $U_{\text{thermo}}$  from the characteristic voltage/temperature curve or table for thermocouple type K:

$$T_{\text{thermo}} = T(24.255 \text{ mV}) = 585 \text{ }^\circ\text{C}$$

The temperature of the measuring point could then be determined with reference to  $0 \text{ }^\circ\text{C}$ :

$$T_{\text{measuring point}} = T_{\text{thermo}} + T_{\text{cold junction}} = 585 \text{ }^\circ\text{C} + 22 \text{ }^\circ\text{C} = 607 \text{ }^\circ\text{C}$$

Note that there is a temperature difference of  $1.5 \text{ }^\circ\text{C}$  between the value with the proper correction (voltage correction, option 1) and the value with the incorrect correction (temperature correction, option 2).

### Evaluation of thermocouples with thermocouple measuring devices

Beckhoff thermocouple measuring devices can evaluate thermocouples of different types. Linearization of the characteristic curves and determination of the reference temperature takes place directly in the measuring device. The measuring device can be fully configured via the Bus Coupler or the controller. Different output formats may be selected or own scaling activated. Linearization of the characteristic curve and determination and calculation of the reference temperature (temperature at the connection contacts of the measuring device) can be disabled, so that the device can be used as a [mV] measuring device or with an external cold junction. In addition to the internal evaluation of the measured voltage for conversion into a temperature, the raw voltage value can be transferred from the measuring device to the control system for further processing.

Temperature measurement with thermocouples generally comprises three steps:

- Measuring the electrical voltage

- Optional: Temperature measurement of the cold junction
- Software-based conversion of the voltage into a temperature value according to the set thermocouple type (K, J, ...)

All three steps can take place locally in the Beckhoff measuring device. Transformation in the measuring device can be disabled if it is to take place in the higher-level control system. Depending on the measuring device type, several thermocouple conversion options are available, which differ in terms of their software implementation.

### Uncertainties in the evaluation of thermocouples with thermocouple measuring devices

The thermocouple measurement consists of a chain of measuring and computing elements that affect the attainable measurement deviation:

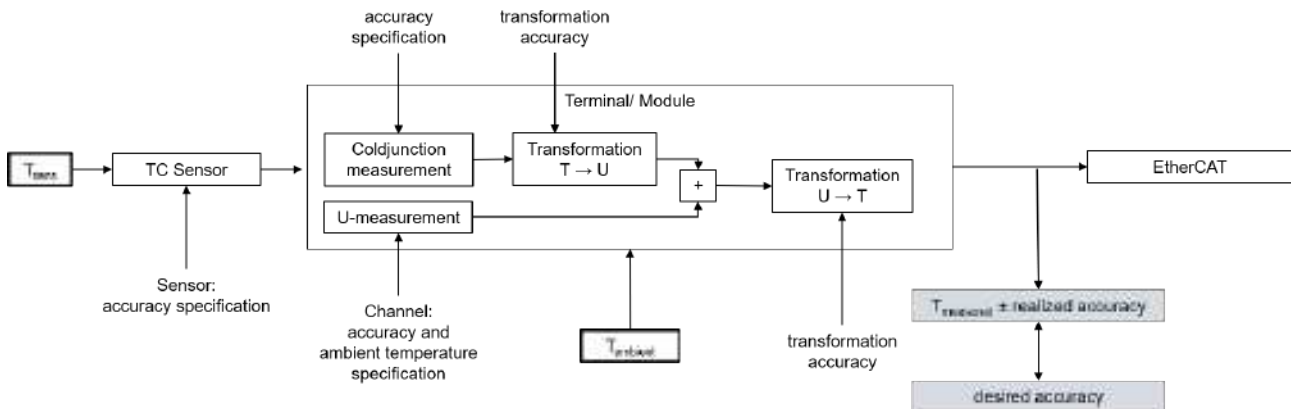

Fig. 8: Concatenation of the uncertainties in temperature measurement with thermocouples

When measuring a temperature, there are various factors influencing the accuracy, from which the total inaccuracy (total uncertainty) is then derived.

#### Uncertainty of the voltage measurement

First and foremost, measuring a temperature with thermocouples is not based on an actual temperature measurement, but a voltage measurement with subsequent conversion into a temperature. The accuracy of the voltage measurement is therefore the basis for the accuracy of the temperature determination. Since a change of 1 °C at the sensor causes a change in the single-digit  $\mu\text{V}$  range, depending on the thermocouple type, even a small uncertainty of the voltage measurement has a large influence on the final result.

#### Uncertainty of the temperature conversion

The conversion of the measured voltage into a temperature is carried out during evaluation either by means of value tables from the characteristic voltage/temperature curve of a thermocouple type or by approximation based on a polynomial. Due to the non-linearity of the characteristic voltage/temperature curve, both options are only approximations of the actual values, so that the conversion results in a further (small) uncertainty component from the transformation.

#### Uncertainty of the cold junction evaluation

Cold junction compensation in thermocouple measuring devices must be carried out at the transition from the thermocouple to the copper contacts of the electronics. However, in many cases the temperature at this point cannot be measured directly for mechanical reasons. In this case the temperature of the cold junction has to be approximated at a distance of a few millimeters or through an average value of the housing temperatures. Since the exact value cannot be determined in this way, this results in further uncertainty.

#### Uncertainty of the sensor

The three factors influencing the uncertainty referred to above relate to the uncertainties in the evaluation of the thermocouples. The accuracy of the thermocouple itself is another factor and must also be taken into account.

Since temperature measurement with thermocouples is actually a voltage measurement and the thermocouples have a non-linear characteristic voltage/temperature curve, it is not possible to simply add up the individual temperature uncertainties to obtain the total uncertainty. To calculate the total uncertainty, all temperature values must be converted into the corresponding voltage value of the respective thermocouple type. When the temperatures are added together an error occurs, as described in the example in the chapter on "Determination of the absolute temperature".

The following diagram shows an example of an analysis of the uncertainties associated with the evaluation of a thermocouple for an EL331x thermocouple terminal with internal cold junction compensation and conversion of the voltage into a temperature via a second degree polynomial. The diagram does not take into account the uncertainty of the thermocouple itself, which is an additional factor!

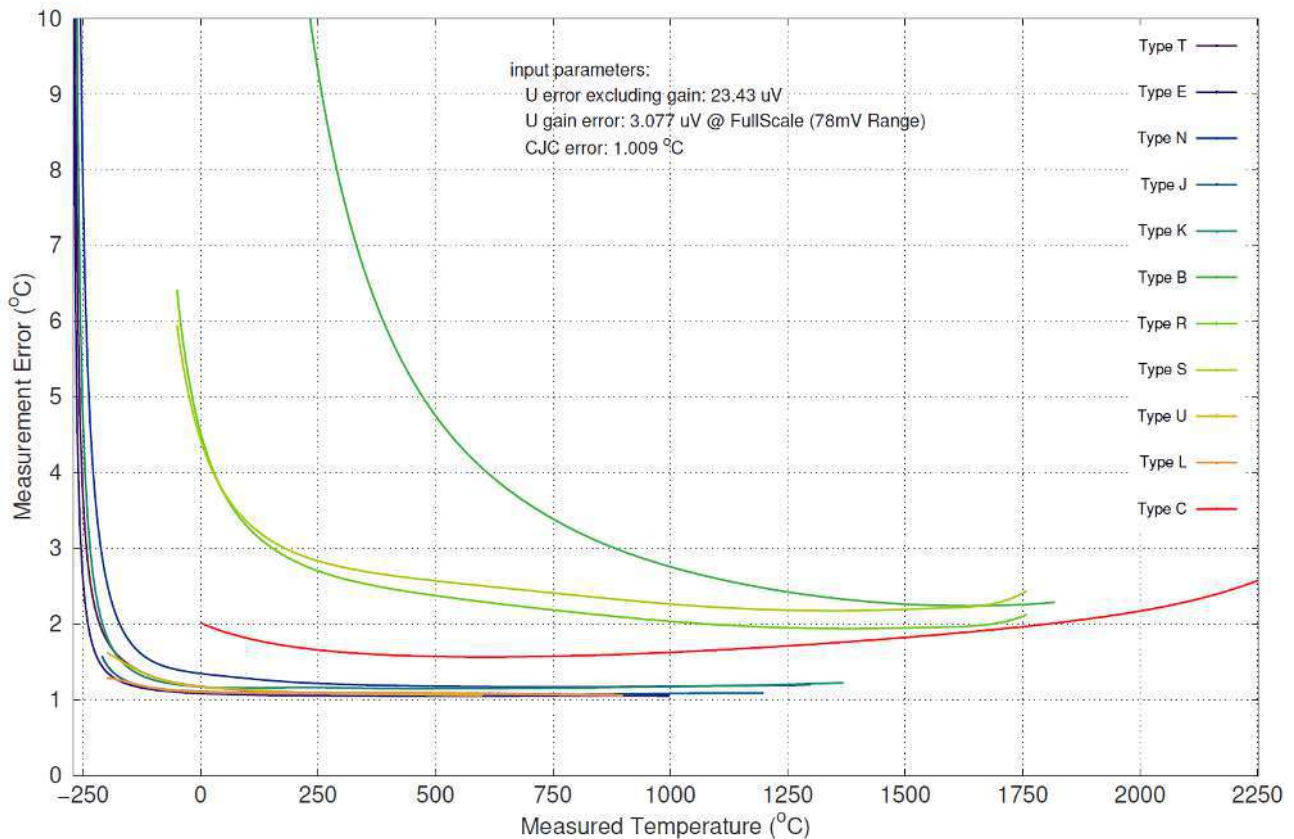

Fig. 9: Example of a thermocouple evaluation uncertainty analysis with an EL331x thermocouple terminal

It is clear from the diagram that the uncertainty of the measured temperature depends on the temperature to be measured. Especially in the lower temperature range, where there is a strong non-linearity of voltage and temperature, the uncertainty of the temperature measurement increases significantly.

Beckhoff offers several products for the evaluation of thermocouples, including

- EL331x-0000: EtherCAT terminal, 1/2/4/8 channel analog input, temperature, thermocouple, 16 bit
- EL3314-0002: EtherCAT terminal, 4 channel analog input, temperature, thermocouple, 24 bit, electrically isolated
- EL3314-0010: EtherCAT terminal, 4 channel analog input, temperature, thermocouple, 24 bit, high-precision
- EL3314-0030: EtherCAT terminal, 4 channel analog input, temperature, thermocouple, 24 bit, high-precision, external calibrated
- EL3314-0090: EtherCAT terminal, 4 channel analog input, temperature, thermocouple, 16 bit, TwinSAFE SC
- ELM370x-xxxx: EtherCAT terminal, 2/4 channel analog input, multi-functional, 24 bit, 10 ksp/s
- ELM334x-xxxx: EtherCAT measurement technology series, thermocouple input, mini thermocouple connector
- EP3314-0002: EtherCAT Box, 4 channel analog input, temperature, thermocouple, 16 bit, M12

- EPP3314-0002: EtherCAT P Box, 4 channel analog input, temperature, thermocouple, 16 bit, M12
- KL331x: bus terminal, 1/2/4 channel analog input, temperature, thermocouple, 16 bit
- EJ3318: EtherCAT plug-in module, 8 channel analog input, temperature, thermocouple, 16 bit

The current overview can be found at [www.beckhoff.com](http://www.beckhoff.com)

## 6 Mounting and connection

### 6.1 Mounting

#### 6.1.1 Dimensions

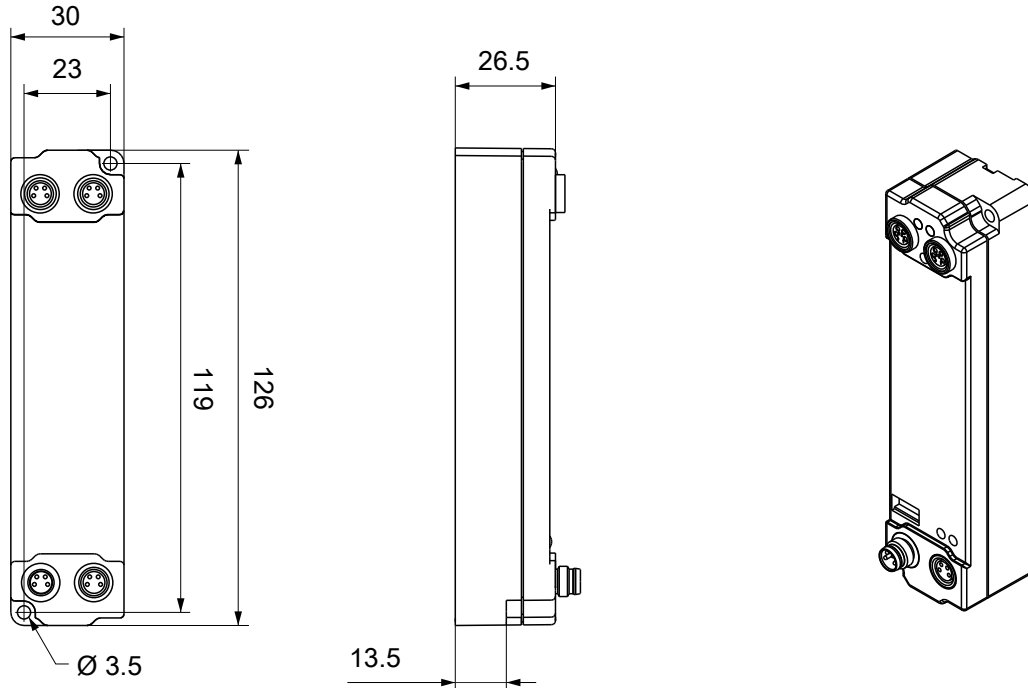

All dimensions are given in millimeters.  
The drawing is not true to scale.

#### Housing features

Housing material	PA6 (polyamide)
Sealing compound	polyurethane
Mounting	two fastening holes $\varnothing 3.5$ mm for M3
Metal parts	brass, nickel-plated
Contacts	CuZn, gold-plated
Power feed through	max. 4 A
Installation position	variable
Protection class	IP65, IP66, IP67 (conforms to EN 60529) when screwed together
Dimensions (H x W x D)	approx. 126 x 30 x 26.5 mm (without connectors)

## 6.1.2 Fixing

### NOTE

#### Dirt during assembly

Dirty connectors can lead to malfunctions. Protection class IP67 can only be guaranteed if all cables and connectors are connected.

- Protect the plug connectors against dirt during the assembly.

Mount the module with two M3 screws on the fastening holes in the corners of the module. The fastening holes have no thread.

## 6.1.3 Tightening torques for plug connectors

Screw connectors tight with a torque wrench. (e.g. ZB8801 from Beckhoff)

Connector diameter	Tightening torque
M8	0.4 Nm
M12	0.6 Nm

## 6.2 Connection

### 6.2.1 Supply voltages

The EtherCAT Box is supplied with two supply voltages. The supply voltages are electrically isolated in the EtherCAT Box.

- Control voltage  $U_s$
- Peripheral voltage  $U_p$

#### Redirection of the supply voltages

The IN and OUT power connections are bridged in the module (not IP204x-Bxxx and IE204x). The supply voltages  $U_s$  and  $U_p$  can thus easily be transferred from EtherCAT Box to EtherCAT Box.

#### **NOTE**

##### **Pay attention to the maximum permissible current!**

Pay attention also for the redirection of the supply voltages  $U_s$  and  $U_p$ , the maximum permissible current for M8 connectors of 4 A must not be exceeded!

#### **NOTE**

##### **The electrical isolation between $GND_s$ and $GND_p$ can be removed**

In some EtherCAT Box modules the ground potentials  $GND_s$  and  $GND_p$  are linked.

If several EtherCAT Box modules are supplied with the same electrically isolated voltages, check whether there is an EtherCAT Box among them in which the ground potentials are linked.

### 6.2.1.1 Connectors

**NOTE**

**Risk of confusion: supply voltages and EtherCAT**

Defect possible through incorrect insertion.

- Observe the color coding of the connectors:  
 black: Supply voltages  
 green: EtherCAT

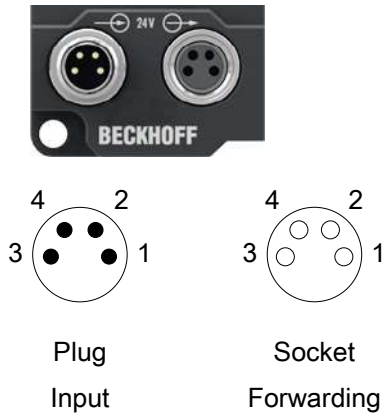

Fig. 10: M8 connector

Contact	Function	Description	Core color <sup>1)</sup>
1	$U_S$	Control voltage	Brown
2	$U_P$	Peripheral voltage	White
3	$GND_S$	GND to $U_S$	Blue
4	$GND_P$	GND to $U_P$	Black

<sup>1)</sup> The core colors apply to cables of the type: Beckhoff ZK2020-3xxx-xxxx

### 6.2.1.2 Status LEDs



LED	Display	Meaning
$U_S$ (control voltage)	off	Supply voltage $U_S$ is not present
	green illuminated	Supply voltage $U_S$ is present
$U_P$ (peripheral voltage)	off	Supply voltage $U_P$ is not present
	green illuminated	Supply voltage $U_P$ is present



### 6.2.1.3 Conductor losses

Take into account the voltage drop on the supply line when planning a system. Avoid the voltage drop being so high that the supply voltage at the box lies below the minimum nominal voltage.

Variations in the voltage of the power supply unit must also be taken into account.

#### Voltage drop on the supply line

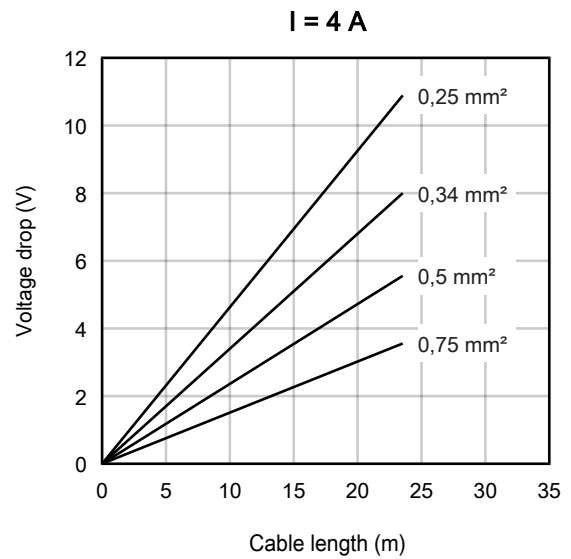
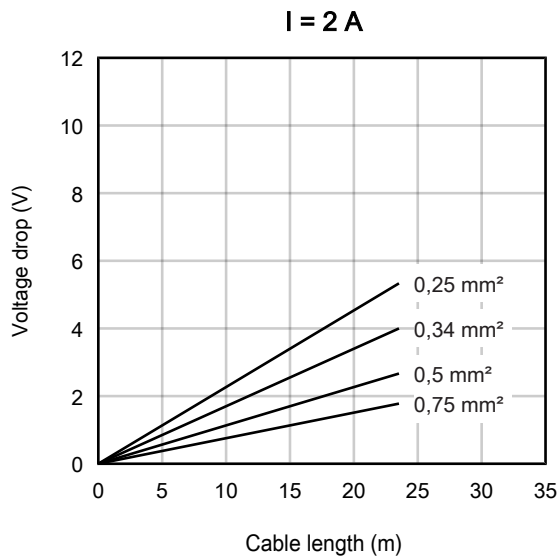

## 6.2.2 EtherCAT

### 6.2.2.1 Connectors

**NOTE**

**Risk of confusion: supply voltages and EtherCAT**

Defect possible through incorrect insertion.

- Observe the color coding of the connectors:  
 black: Supply voltages  
 green: EtherCAT

EtherCAT Box Modules have two green M8 sockets for the incoming and downstream EtherCAT connections.



**Connection**

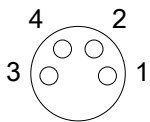

Fig. 11: M8 socket

EtherCAT	M8 connector	Core colors		
Signal	Contact	ZB9010, ZB9020, ZB9030, ZB9032, ZK1090-6292, ZK1090-3xxx-xxxx	ZB9031 and old versions of ZB9030, ZB9032, ZK1090-3xxx-xxxx	TIA-568B
Tx +	1	yellow <sup>1)</sup>	orange/white	white/orange
Tx -	4	orange <sup>1)</sup>	orange	orange
Rx +	2	white <sup>1)</sup>	blue/white	white/green
Rx -	3	blue <sup>1)</sup>	blue	green
Shield	Housing	Shield	Shield	Shield

<sup>1)</sup> Core colors according to EN 61918

**i Adaptation of core colors for cables ZB9030, ZB9032 and ZK1090-3xxxx-xxxx**

For standardization, the core colors of the ZB9030, ZB9032 and ZK1090-3xxx-xxxx cables have been changed to the EN61918 core colors: yellow, orange, white, blue. So there are different color codes in circulation. The electrical properties of the cables have been retained when the core colors were changed.

**6.2.2.2 Status LEDs**



**L/A (Link/Act)**

A green LED labelled "L/A" is located next to each EtherCAT socket. The LED indicates the communication state of the respective socket:

LED	Meaning
off	no connection to the connected EtherCAT device
lit	LINK: connection to the connected EtherCAT device
flashes	ACT: communication with the connected EtherCAT device

**Run**

Each EtherCAT slave has a green LED labelled "Run". The LED signals the status of the slave in the EtherCAT network:

LED	Meaning
off	Slave is in "Init" state
flashes uniformly	Slave is in "Pre-Operational" state
flashes sporadically	Slave is in "Safe-Operational" state
lit	Slave is in "Operational" state

Description of the EtherCAT slave states

**6.2.2.3 Cables**

For connecting EtherCAT devices only shielded Ethernet cables that meet the requirements of at least category 5 (CAT5) according to EN 50173 or ISO/IEC 11801 should be used.

EtherCAT uses four wires for signal transmission. Thanks to automatic line detection ("Auto MDI-X"), both symmetrical (1:1) or cross-over cables can be used between Beckhoff EtherCAT.

Detailed recommendations for the cabling of EtherCAT devices

## 6.2.3 Signal connection

### 6.2.3.1 EP3204: Pt100 (RTD)

The advantage of four-wire technique is that the error resulting from the cable and contacts is included in the measurement and cancelled out. In the 3-wire technique, the line resistance to the resistance sensor is measured in one direction only, and is multiplied by two. This requires the outward and return lines to have approximately the same ohmic resistance. An error is present in the two-wire technique; temperature differences and cable cross-sections can make this error vary considerably.

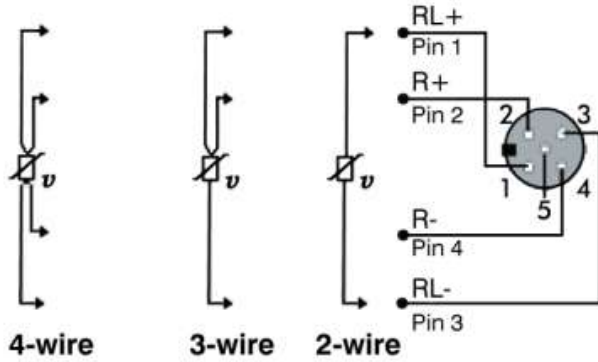

6.2.3.2 EP3314: Thermocouples

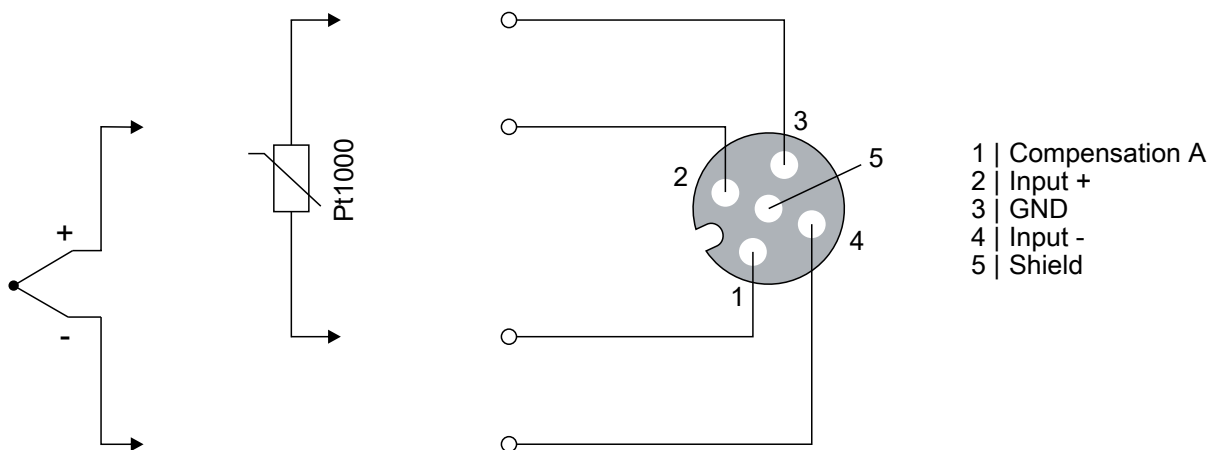

**Cold junction compensation**

The cold junction temperature is not measured in the box. For cold junction compensation, a Pt1000 measuring resistor must be connected in addition to the thermocouple. Place the Pt1000 measuring resistor as close as possible to the cold junction.

Recommendation: Use the ZS2000-3712 connector from Beckhoff instead of a separate Pt1000 measuring resistor. The ZS2000-3712 has an integrated Pt1000 measuring resistor that measures the temperature directly at the cold junction.

The highest accuracy can be achieved if a ZS2000-3712 or a Pt1000 measuring resistor is used for each connection. See [Connection example 1](#) [▶ 38].

Alternatively, you can save costs by connecting a ZS2000-3712 or a Pt1000 measuring resistor to channel 1 only. In this case cold junction compensation of the other channels is carried out with the cold junction temperature of channel 1. See [Connection example 2](#) [▶ 39].

**Extension cable**

You can use an M12 extension cable between the box and the cold junction. However, this reduces the measuring accuracy. The longer the extension cable, the greater the measuring error.

The maximum permissible cable length between the box and the thermocouple is 30 m.

**6.2.3.2.1 Connection example 1**

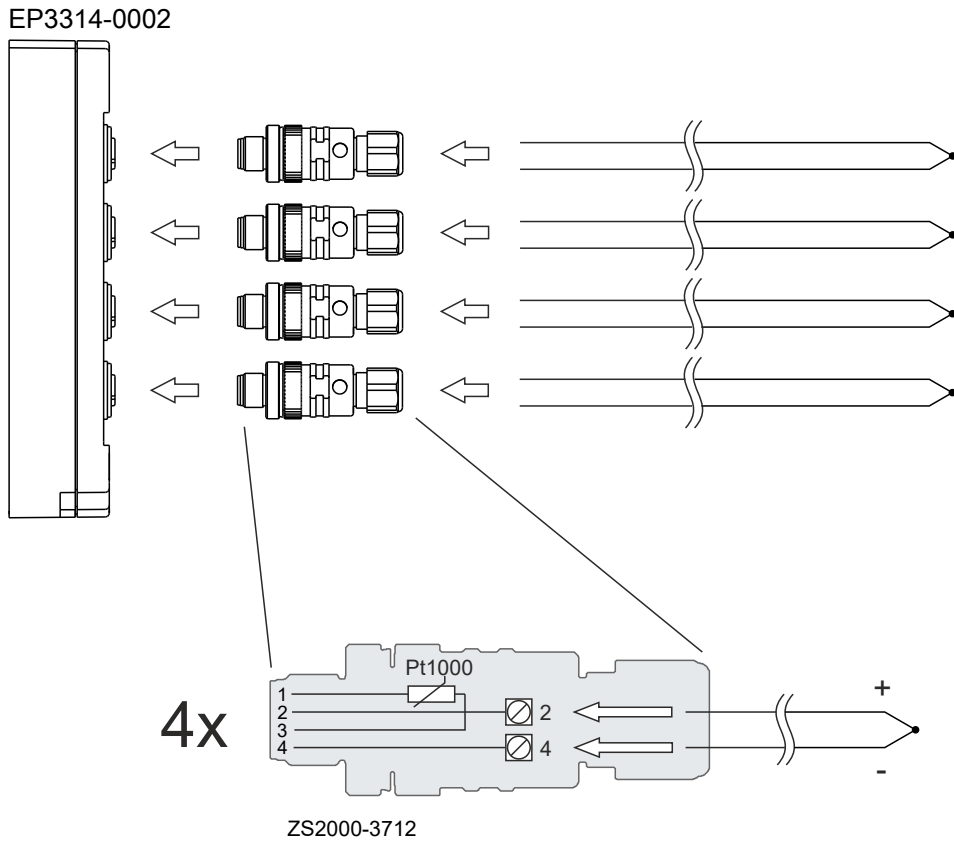

In this connection example, four connectors of type ZS2000-3712 with integrated measuring resistor are used. Cold junction compensation is performed for each channel individually.

The CoE parameters 80n0:0C "Coldjunction compensation" must be set to the value 0 "intern" for all channels. This is the factory setting. See chapter [Cold junction compensation](#) [► 74].

**6.2.3.2.2 Connection example 2**

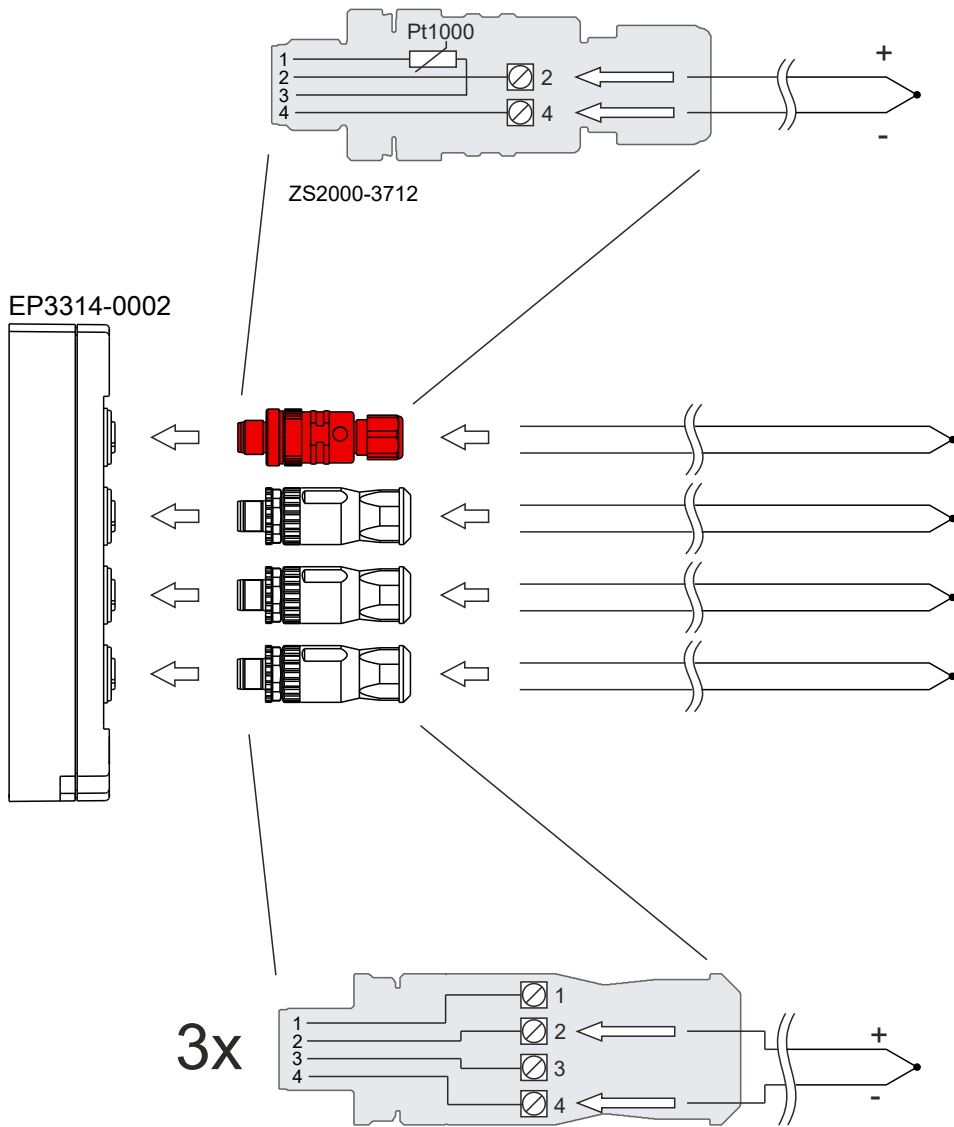

In this connection example only one connector with integrated measuring resistor type ZS2000-3712 is used. The thermocouples are connected to the other channels via standard M12 connectors.

Set the CoE parameters of the channels as follows:

CoE parameters	Value
8000:0C <sub>hex</sub>	0 "internal"
8010:0C <sub>hex</sub>	3 „by coldjunction temp. of channel 1“
8020:0C <sub>hex</sub>	3 „by coldjunction temp. of channel 1“
8030:0C <sub>hex</sub>	3 „by coldjunction temp. of channel 1“

See chapter [Cold junction compensation](#) [► 74].

### 6.2.3.3 Status LEDs at the signal connections

There is a green *Run* LED and a red *Error* LED for each channel.  
Correct function is indicated if the green *Run* LED is on and the red *Error* is off.

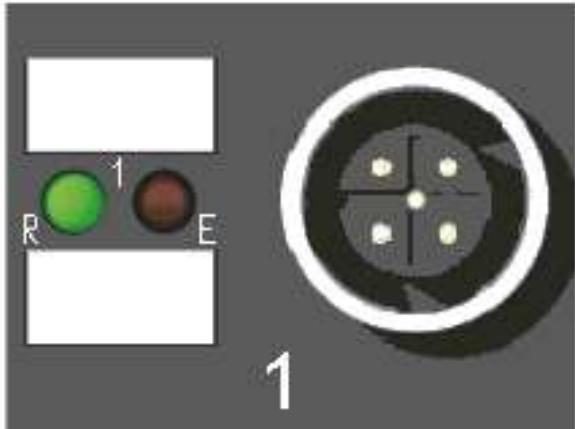

Fig. 12: Status LEDs at the signal connections

Connection	LED	Display	Meaning
M12 socket no. 1-4	R left	off	No data transfer to the A/D converter
		green	Data transfer to A/D converter
	E right	off	Function OK
		red	Error: <ul style="list-style-type: none"> <li>• Broken wire or</li> <li>• measured value outside measuring range or</li> <li>• temperature compensation outside the valid range</li> </ul>



## 6.3 UL Requirements

The installation of the EtherCAT Box Modules certified by UL has to meet the following requirements.

### Supply voltage

#### ⚠ CAUTION

##### CAUTION!

This UL requirements are valid for all supply voltages of all marked EtherCAT Box Modules!  
For the compliance of the UL requirements the EtherCAT Box Modules should only be supplied

- by a 24 V<sub>DC</sub> supply voltage, supplied by an isolating source and protected by means of a fuse (in accordance with UL248), rated maximum 4 Amp, or
- by a 24 V<sub>DC</sub> power source, that has to satisfy *NEC class 2*.  
A *NEC class 2* power supply shall not be connected in series or parallel with another (class 2) power source!

#### ⚠ CAUTION

##### CAUTION!

To meet the UL requirements, the EtherCAT Box Modules must not be connected to unlimited power sources!

### Networks

#### ⚠ CAUTION

##### CAUTION!

To meet the UL requirements, EtherCAT Box Modules must not be connected to telecommunication networks!

### Ambient temperature range

#### ⚠ CAUTION

##### CAUTION!

To meet the UL requirements, EtherCAT Box Modules has to be operated only at an ambient temperature range of -25 °C to +55 °C!

### Marking for UL

All EtherCAT Box Modules certified by UL (Underwriters Laboratories) are marked with the following label.



Fig. 13: UL label

## 6.4 ATEX notes

### 6.4.1 ATEX - Special conditions

#### ⚠ WARNING

**Observe the special conditions for the intended use of EtherCAT Box modules in potentially explosive areas – directive 94/9/EU.**

- The certified components are to be installed with a BG2000-0000 or BG2000-0010 protection enclosure [► 43] that guarantees a protection against mechanical hazards!
- If the temperatures during rated operation are higher than 70°C at the feed-in points of cables, lines or pipes, or higher than 80°C at the wire branching points, then cables must be selected whose temperature data correspond to the actual measured temperature values!
- Observe the permissible ambient temperature range of 0 to 55°C for the use of EtherCAT Box modules in potentially explosive areas!
- Measures must be taken to protect against the rated operating voltage being exceeded by more than 40% due to short-term interference voltages!
- The connections of the certified components may only be connected or disconnected if the supply voltage has been switched off or if a non-explosive atmosphere is ensured!

#### Standards

The fundamental health and safety requirements are fulfilled by compliance with the following standards:

- EN 60079-0: 2006
- EN 60079-15: 2005

#### Marking

The EtherCAT Box modules certified for potentially explosive areas bear the following marking:



II 3 G Ex nA II T4 DEKRA 11ATEX0080 X Ta: 0 - 55°C

or



II 3 G Ex nA nC IIC T4 DEKRA 11ATEX0080 X Ta: 0 - 55°C

#### Batch number (D number)

The EtherCAT Box modules bear a batch number (D number) that is structured as follows:

D: WW YY FF HH

WW - week of production (calendar week)

YY - year of production

FF - firmware version

HH - hardware version

Example with batch number 29 10 02 01:

29 - week of production 29

10 - year of production 2010

02 - firmware version 02

01 - hardware version 01

## 6.4.2 BG2000 - EtherCAT Box protection enclosures

### ⚠ WARNING

#### Risk of electric shock and damage of device!

Bring the EtherCAT system into a safe, powered down state before starting installation, disassembly or wiring of the modules!

### ATEX

### ⚠ WARNING

#### Mount a protection enclosure!

To fulfill the special conditions according to ATEX [▶ 42], a BG2000-0000 or BG2000-0010 protection enclosure has to be mounted over the EtherCAT Box.

### Installation

Put the cables for EtherCAT, power supply and sensors/actuators through the hole of the protection enclosure.

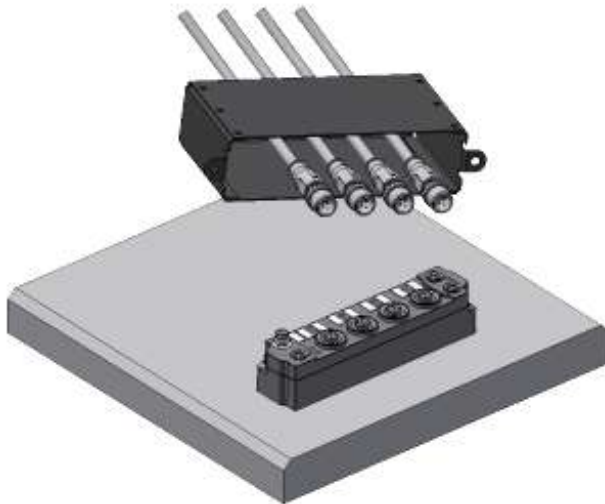

Fig. 14: BG2000 - putting the cables

Fix the wires for EtherCAT, power supply and sensors/actuators to the EtherCAT Box.

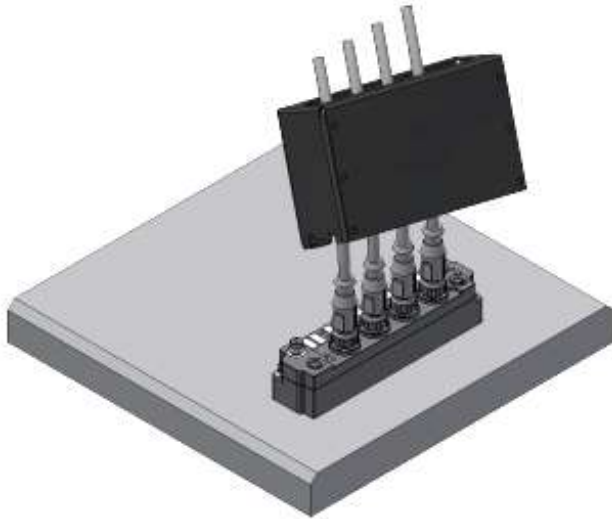

Fig. 15: BG2000 - fixing the cables

Mount the protection enclosure over the EtherCAT Box.

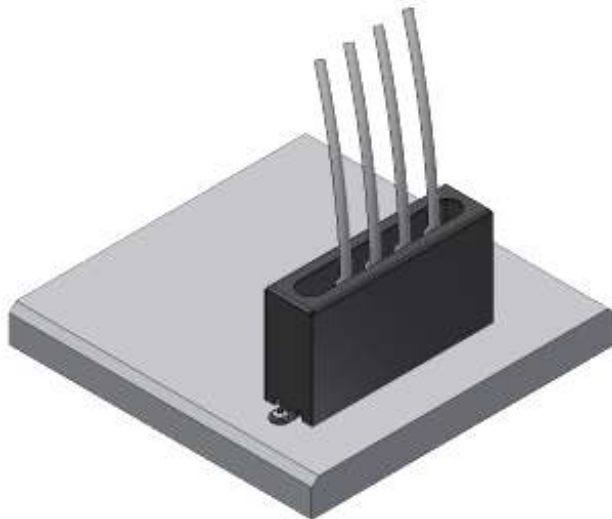

Fig. 16: BG2000 - mounting the protection enclosure

### 6.4.3 ATEX Documentation



#### Notes about operation of EtherCAT Box Modules (EPxxxx-xxxx) in potentially explosive areas (ATEX)

Pay also attention to the continuative documentation Notes about operation of EtherCAT Box Modules (EPxxxx-xxxx) in potentially explosive areas (ATEX) that is available in the download area of the Beckhoff homepage <http://www.beckhoff.com>!

## 7 Commissioning/Configuration

### 7.1 Integration in TwinCAT

The procedure for integration in TwinCAT is described in this [Quick start guide](#).

### 7.2 EP3204 – Data stream and calculation of the process data

#### 7.2.1 Vendor calibration

##### 7.2.1.1 2 and 4-wire resistance measurement

Whether a measurement is executed as a 2 or 4-wire measurement is determined by the connection points at which the measurement takes place. A comparison value is stored in the firmware for both measuring methods.

- **With the 2-wire measurement**

- a current is applied between the contact points RL+ und RL- and the voltage drop is measured in order to determine the resistance.
- The parasitic line resistance cannot be determined by the box itself, but must be entered as a correction value in the CoE register 0x80n0:1B.

- **With the 4-wire measurement**

- the sensor current is applied between the contact points RL+ und RL- of the M12 socket and the voltage drop at the contact points R+ and R- is used to measure the resistance.
- The conducting wire is thus not part of the measuring circuit and is not incorporated into the measurement as a source of error.

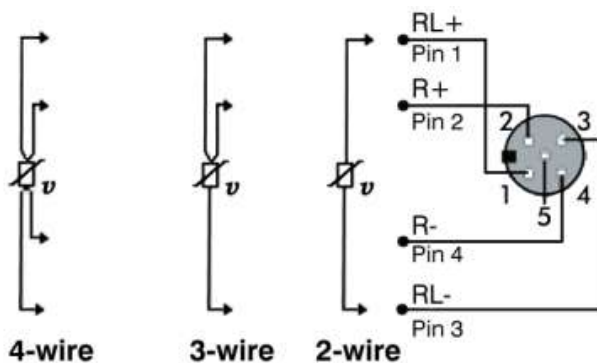

Fig. 17: Resistance measurement with a 4-wire, 3-wire and 2-wire connection technique

The box uses the following calculation rule:

$$Y_R = \frac{(X+O_V)}{2^2} \cdot \frac{G_V}{2^{14}}$$

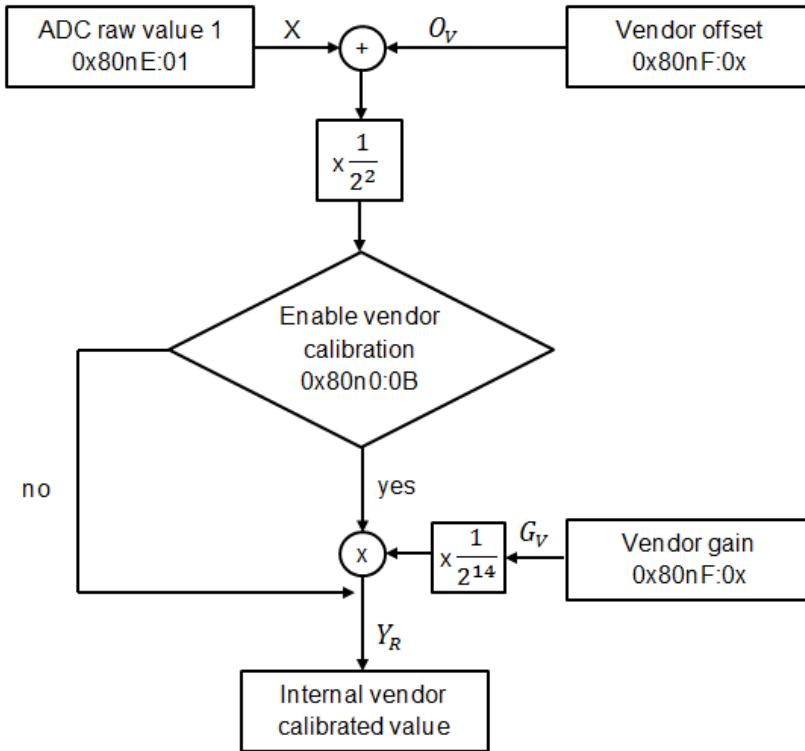

Fig. 18: Data flow: resistance measurement with a 2 and 4-wire connection technique

With the values:

	Index in the CoE directory with n: channel number with 0 ≤ n ≤ 3 (channel 1 - 4)			
X: Raw value	0x80nE:01			
	Pt100		Pt1000	
	2-wire	4-wire	2-wire	4-wire
Gv: Vendor Gain	0x80nF:04	0x80nF:06	0x80nF:0A	0x80nF:0C
Ov: Vendor Offset	0x80nF:03	0x80nF:05	0x80nF:09	0x80nF:0B
Y <sub>R</sub> : Output value in 1/256 Ω	0x80nE:02			

**i Overflow Y<sub>R</sub> after 16 bits**

This value is only for fault finding. The register overflows after 16 bits, i.e. at 65536.

### 7.2.1.2 3-wire resistance measurement

• With the 3-wire measurement

- a defined current is initially applied between the contact points RL+ und RL- and the resistance between them is determined on the basis of the voltage drop.
- The same procedure is subsequently carried out at the contact points RL+ und R-.
- The difference between the two measurements is the line resistance of one of the cores of the sensor cable. By knowing the line resistance the resulting measuring error can be compensated.
- The cores of the sensor cable must have the same resistance in order for the method to work.

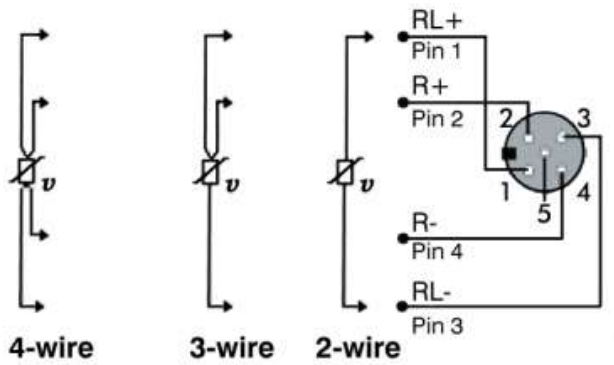

Fig. 19: Resistance measurement with a 4-wire, 3-wire and 2-wire connection technique

**The box uses the following calculation rule**

$$Y_{R1} = \frac{(X_1 + O_{V1})}{2^2} \cdot \frac{G_{V1}}{2^{14}}, Y_{R2} = \frac{(X_2 + O_{V2})}{2^2} \cdot \frac{G_{V2}}{2^{14}}$$

$$Y_R = Y_{R2} - (Y_{R1} - Y_{R2}) = 2Y_{R2} - Y_{R1}$$

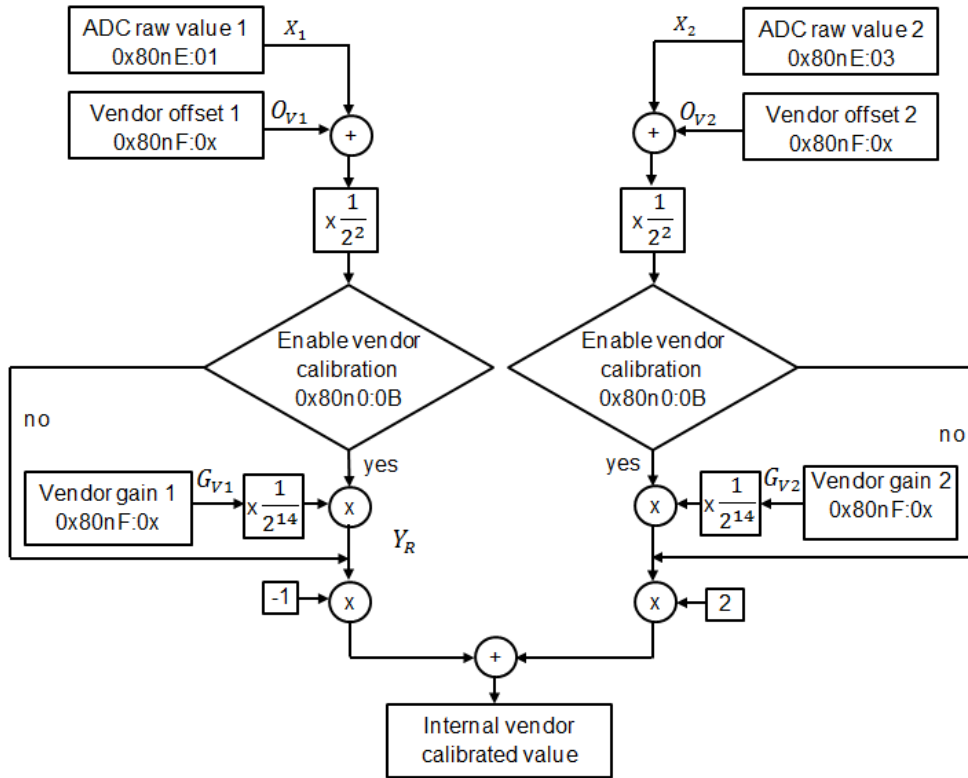

Fig. 20: Data flow: resistance measurement with a 3-wire connection technique

With the values:

	Index in the CoE directory with n: channel number with 0 ≤ n ≤ 3 (channel 1 - 4)	
X <sub>1</sub> : raw value of the 1 <sup>st</sup> measurement	0x80nE:01	
X <sub>2</sub> : raw value of the 2 <sup>nd</sup> measurement	0x80nE:03	
	Pt100	Pt1000
G <sub>V1</sub> : Vendor gain, 1 <sup>st</sup> measurement	0x80nF:04	0x80nF:0A
O <sub>V1</sub> : Vendor offset, 1 <sup>st</sup> measurement	0x80nF:03	0x80nF:09
G <sub>V2</sub> : Vendor gain, 2 <sup>nd</sup> measurement	0x80nF:02	0x80nF:08
O <sub>V2</sub> : Vendor offset, 2 <sup>nd</sup> measurement	0x80nF:01	0x80nF:07
Y <sub>R1</sub> : Output value in 1/256 Ω	0x80nE:02	
Y <sub>R2</sub> : Output value in 1/256 Ω	0x80nE:04	
Y <sub>R</sub> : Output value in 1/256 Ω		

**i Overflow Y<sub>R1</sub> and Y<sub>R2</sub> after 16 bits**

These values are only for fault finding. The registers overflow after 16 bits, i.e. at 65536.



### 7.2.2 User calibration and linearization

- The calibrated measured value may also be modified by the user calibration values.
- The result of the resistance measurement is mapped onto a temperature value. The fundamental linearization function cannot be modified by the user.
- The user scaling is only included after the linearization.

The box uses the following calculation rule

$$Y_{int} = X_V \cdot \frac{G_U}{2^{14}} + O_U$$

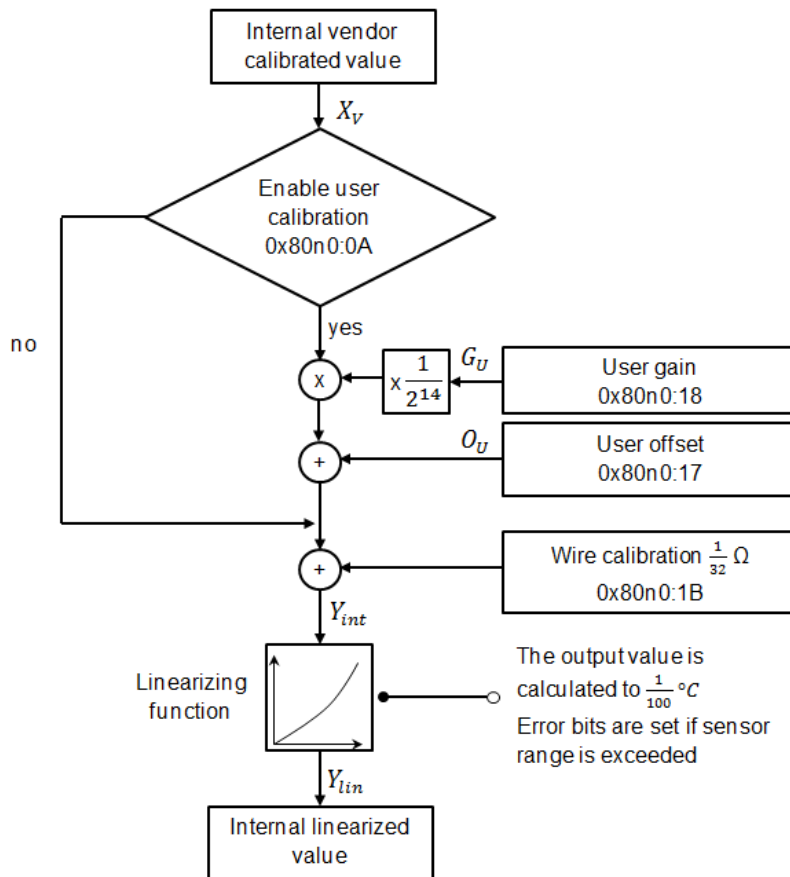

Fig. 21: Data flow: user compensation and linearization

With the values:

	Index in the CoE directory with n: channel number with 0 ≤ n ≤ 3 (channel 1 - 4)
X <sub>v</sub> : Output value of the vendor calibration	
G <sub>U</sub> : User Gain	0x80n0:18
O <sub>U</sub> : User Offset	0x80n0:17
Y <sub>int</sub> : Output value in 1/256 Ω prior to the linearization	

### 7.2.3 Scaling, limits and formatting

- Following the calculation of the resistance value, the scaling and the limit bits are evaluated.
- The result is formatted in accordance with the set presentation and copied into the process image.

The box uses the following calculation rule

$$Y = Y_{lin} \cdot \frac{G_S}{2^{16}} + O_S$$

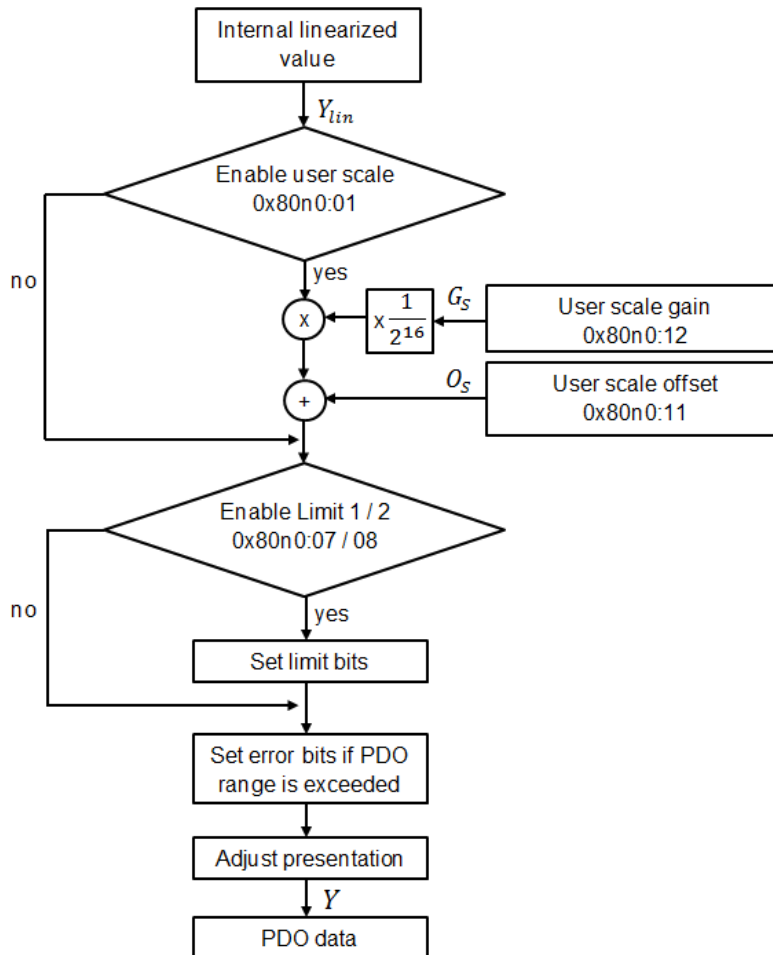

Fig. 22: Data flow: user scaling, limit evaluation, error bits and formatting

With the values:

	Index in the CoE directory with n: channel number with $0 \leq n \leq 3$ (channel 1 - 4)
$Y_{lin}$ : Output value in 1/100 °C	
$G_S$ : User Scale Gain	0x80n0:12
$O_S$ : User Scale Offset	0x80n0:11
Y: Output value PDO	

## 7.2.4 Summary

Summary of the calculation rules:

Vendor calibration <b>2- and 4-wire</b> measurement	$Y_R = \frac{(X_1 + O_V)}{2^2} \cdot \frac{G_V}{2^{14}}$
Vendor calibration <b>3-wire</b> measurement	$Y_{R1} = \frac{(X_1 + O_{V1})}{2^2} \cdot \frac{G_{V1}}{2^{14}}, Y_{R2} = \frac{(X_2 + O_{V2})}{2^2} \cdot \frac{G_{V2}}{2^{14}}$ $Y_R = 2Y_{R2} - Y_{R1}$
User calibration and <u>linearization</u>	$Y_{int} = X_V \cdot \frac{G_U}{2^{14}} + O_U$
User scale, <u>limits</u> and presentation	$Y = Y_{lin} \cdot \frac{G_S}{2^{16}} + O_S$
Summary <b>2-, 4-wire</b> measurement	$Y = f_{pres} \left( \frac{G_S}{2^{16}} \cdot f_{lin} \left( \frac{(X_1 + O_V)}{2^2} \cdot \frac{G_V}{2^{14}} \cdot \frac{G_U}{2^{14}} + O_U \right) + O_S \right)$
Summary <b>3-wire</b> measurement	$Y = f_{pres} \left( \frac{G_S}{2^{16}} \cdot f_{lin} \left( (2Y_{R2} - Y_{R1}) \cdot \frac{G_V}{2^{14}} \cdot \frac{G_U}{2^{14}} + O_U \right) + O_S \right)$

With the values:

	Index in the CoE directory with n: channel number with 0 ≤ n ≤ 3 (channel 1 - 4)			
X <sub>1</sub> : Raw value of the 1 <sup>st</sup> measurement	0x80nE:01			
X <sub>2</sub> : Raw value of the 2 <sup>nd</sup> measurement	0x80nE:03			
	<b>Pt100</b>		<b>Pt1000</b>	
	<b>2-wire</b>	<b>4-wire</b>	<b>2-wire</b>	<b>4-wire</b>
G <sub>v</sub> : Vendor Gain	0x80nF:04	0x80nF:06	0x80nF:0A	0x80nF:0C
O <sub>v</sub> : Vendor Offset	0x80nF:03	0x80nF:05	0x80nF:09	0x80nF:0B
	<b>3-wire</b>			
G <sub>v1</sub> : Vendor gain, 1 <sup>st</sup> measurement	0x80nF:04		0x80nF:0A	
O <sub>v1</sub> : Vendor offset, 1 <sup>st</sup> measurement	0x80nF:03		0x80nF:09	
G <sub>v2</sub> : Vendor gain, 2 <sup>nd</sup> measurement	0x80nF:02		0x80nF:08	
O <sub>v2</sub> : Vendor offset, 2 <sup>nd</sup> measurement	0x80nF:01		0x80nF:07	
G <sub>u</sub> : User Gain	0x80n0:18			
O <sub>u</sub> : User Scale Offset	0x80n0:17			
G <sub>s</sub> : User Scale Gain	0x80n0:12			
O <sub>s</sub> : User Scale Offset	0x80n0:11			
f <sub>lin</sub> : Function for mapping to the selected method of representation				
f <sub>pres</sub> : Linearization function				
Y <sub>R1</sub> : Output value in 1/256 Ω	0x80nE:02			
Y <sub>R2</sub> : Output value in 1/256 Ω	0x80nE:04			
Y: Output value PDO				

### **i** Overflow Y<sub>R1</sub> and Y<sub>R2</sub> after 16 bits

These values are only for fault finding. The registers overflow after 16 bits, i.e. at 65536.

## 7.2.5 Two-point user calibration

The vendor calibration is to be deactivated via index (0x80n0:0B).

Up to FW version 07 the deactivation of the vendor calibration only results in the vendor gain being set to  $2^{14}$  (fixed-point representation for 1.0). The vendor offset remains unchanged and is still included. This results in the following with vendor calibration deactivated:

$$Y_{int} = (X + O_V) \cdot G_U \cdot \frac{1}{2^{16}} + O_U$$

$$Y_{int} = X \cdot G_U \cdot \frac{1}{2^{16}} + \underbrace{O_V \cdot G_U \cdot \frac{1}{2^{16}} + O_U}_{constant}$$

Since the last part of the term is constant, a user calibration can be performed despite the unavoidable influence of the vendor offset. The influence of the vendor offset can thereby be fully compensated. The following method is to be applied:

Carry out two reference measurements with  $Y_1(X_1)$  and  $Y_2(X_2)$ . Then the following applies:

$$g_f = \frac{X_2 - X_1}{Y_2 - Y_1} \quad (1)$$

$$G_U = g_f \cdot 2^{16} \quad (2)$$

$$O_U = X_1 - (Y_1 + O_V) \cdot g_f \quad (3)$$

$G_U$  and  $O_U$  are to be rounded to the nearest whole number and entered in index 0x80n0:18 and index 0x80n0:17.

X	Raw value (0x80nE:01)
$O_V$ :	Vendor Offset (index depends on the mode, see chapter <a href="#">Vendor calibration [► 45]</a> )
$G_U$ :	User Gain (0x80n0:18)
$O_U$ :	User Offset (0x80n0:17)
$g_f$ :	Gain as a floating value
$O_R$ :	Offset as a raw value
$X_n$ :	Measured raw value with reference measurement $n$
$Y_n$ :	Reference value in $1/256 \Omega$
$Y_{int}$ :	Output value in $1/256 \Omega$ prior to the linearization

### NOTE

#### $Y_n$ : Use of the raw value

Since the resistance value in index 0x8xxE:02 overflows, the raw value in index 0x8xxE:01 is used for  $Y_n$ .

**7.2.5.1 Example**

Channel 1 is to be calibrated with four-wire connection at two points with 100 Ω and 350 Ω. The vendor offset for the 2-wire calibration is -2607 (taken from index 0x800F:03).

The following measured values are recorded:

100 Ω through precision resistor	$X_1 = 25600$ (1/256 Ω)
171125, read in index 0x800E:01	$Y_1 = 171125$
350 Ω through precision resistor	$X_2 = 89600$ (1/256 Ω)
592224, read in index 0x800E:01	$Y_2 = 592224$

With the equations (1) - (3):

$$g_f = \frac{X_2 - X_1}{Y_2 - Y_1} \quad (1)$$

$$G_U = g_f \cdot 2^{16} \quad (2)$$

$$O_U = X_1 - (Y_1 + O_V) \cdot g_f \quad (3)$$

the resulting values for  $g_f$ ,  $G_U$  and  $O_U$  are:

$$g_f = \frac{89600 - 25600}{592224 - 171125} = 0.15198326 \quad (1)$$

$$G_U = 0.15198326 \cdot 2^{16} = 9960.375114 \quad (2)$$

$$O_U = 25600 - (171125 + 2607) \cdot 0.15198326 = -11.915 \quad (3)$$

The indices accept only integer values. The following entries are to be made in the CoE:

- Index 0x8000:17 = -12
- Index 0x8000:18 = 9960

Subsequently the vendor calibration is to be deactivated (0x8000:0B) and the user calibration activated (0x8000:0A).

## 7.3 EP3204 - object overview

### **i** EtherCAT XML Device Description

The display matches that of the CoE objects from the EtherCAT XML Device Description. We recommend downloading the latest XML file from the download area of the Beckhoff website and installing it according to installation instructions.

Index (hex)	Name	Flags	Default value
1000 [▶ 66]	Device type	RO	0x01401389 (20976521 <sub>dec</sub> )
1008 [▶ 66]	Device name	RO	EPP3204-0002
1009 [▶ 66]	Hardware version	RO	01
100A [▶ 66]	Software version	RO	03
1011:0 [▶ 60]	<b>Subindex</b>	Restore default parameters	0x01 (1 <sub>dec</sub> )
	1011:01	SubIndex 001	0x00000000 (0 <sub>dec</sub> )
1018:0 [▶ 66]	<b>Subindex</b>	Identity	0x04 (4 <sub>dec</sub> )
	1018:01	Vendor ID	0x00000002 (2 <sub>dec</sub> )
	1018:02	Product code	0x0C844052 (209993810 <sub>dec</sub> )
	1018:03	Revision	0x00120002 (1179650 <sub>dec</sub> )
	1018:04	Serial number	0x00000000 (0 <sub>dec</sub> )
10F0:0 [▶ 66]	<b>Subindex</b>	Backup parameter handling	0x01 (1 <sub>dec</sub> )
	10F0:01	Checksum	0x00000000 (0 <sub>dec</sub> )
1A00:0 [▶ 67]	<b>Subindex</b>	RTD TxPDO-Map RTDInputs Ch.1	0x0A (10 <sub>dec</sub> )
	1A00:01	SubIndex 001	0x6000:01, 1
	1A00:02	SubIndex 002	0x6000:02, 1
	1A00:03	SubIndex 003	0x6000:03, 2
	1A00:04	SubIndex 004	0x6000:05, 2
	1A00:05	SubIndex 005	0x6000:07, 1
	1A00:06	SubIndex 006	0x0000:00, 6
	1A00:07	SubIndex 007	0x6000:0E, 1
	1A00:08	SubIndex 008	0x1800:07, 1
	1A00:09	SubIndex 009	0x1800:09, 1
	1A00:0A	SubIndex 010	0x6000:11, 16
1A01:0 [▶ 67]	<b>Subindex</b>	RTD TxPDO-Map RTDInputs Ch.2	0x0A (10 <sub>dec</sub> )
	1A01:01	SubIndex 001	0x6010:01, 1
	1A01:02	SubIndex 002	0x6010:02, 1
	1A01:03	SubIndex 003	0x6010:03, 2
	1A01:04	SubIndex 004	0x6010:05, 2
	1A01:05	SubIndex 005	0x6010:07, 1
	1A01:06	SubIndex 006	0x0000:00, 6
	1A01:07	SubIndex 007	0x6010:0E, 1
	1A01:08	SubIndex 008	0x1801:07, 1
	1A01:09	SubIndex 009	0x1801:09, 1
	1A01:0A	SubIndex 010	0x6010:11, 16
1A02:0 [▶ 67]	<b>Subindex</b>	RTD TxPDO-Map RTDInputs Ch.3	0x0A (10 <sub>dec</sub> )
	1A02:01	SubIndex 001	0x6020:01, 1
	1A02:02	SubIndex 002	0x6020:02, 1
	1A02:03	SubIndex 003	0x6020:03, 2
	1A02:04	SubIndex 004	0x6020:05, 2
	1A02:05	SubIndex 005	0x6020:07, 1
	1A02:06	SubIndex 006	0x0000:00, 6
	1A02:07	SubIndex 007	0x6020:0E, 1
	1A02:08	SubIndex 008	0x1802:07, 1
	1A02:09	SubIndex 009	0x1802:09, 1
	1A02:0A	SubIndex 010	0x6020:11, 16

Index (hex)		Name	Flags	Default value
1A03:0 [▶ 67]	<b>Subindex</b>	RTD TxPDO-Map RTDInputs Ch.4	RO	0x0A (10 <sub>dec</sub> )
	1A03:01	SubIndex 001	RO	0x6030:01, 1
	1A03:02	SubIndex 002	RO	0x6030:02, 1
	1A03:03	SubIndex 003	RO	0x6030:03, 2
	1A03:04	SubIndex 004	RO	0x6030:05, 2
	1A03:05	SubIndex 005	RO	0x6030:07, 1
	1A03:06	SubIndex 006	RO	0x0000:00, 6
	1A03:07	SubIndex 007	RO	0x6030:0E, 1
	1A03:08	SubIndex 008	RO	0x1803:07, 1
	1A03:09	SubIndex 009	RO	0x1803:09, 1
	1A03:0A	SubIndex 010	RO	0x6030:11, 16
1C00:0 [▶ 68]	<b>Subindex</b>	Sync manager type	RO	0x04 (4 <sub>dec</sub> )
	1C00:01	SubIndex 001	RO	0x01 (1 <sub>dec</sub> )
	1C00:02	SubIndex 002	RO	0x02 (2 <sub>dec</sub> )
	1C00:03	SubIndex 003	RO	0x03 (3 <sub>dec</sub> )
	1C00:04	SubIndex 004	RO	0x04 (4 <sub>dec</sub> )
1C12:0 [▶ 68]	<b>Subindex</b>	RxPDO assign	RW	0x00 (0 <sub>dec</sub> )
1C13:0 [▶ 68]	<b>Subindex</b>	TxPDO assign	RW	0x04 (4 <sub>dec</sub> )
	1C13:01	SubIndex 001	RW	0x1A00 (6656 <sub>dec</sub> )
	1C13:02	SubIndex 002	RW	0x1A01 (6657 <sub>dec</sub> )
	1C13:03	SubIndex 003	RW	0x1A02 (6658 <sub>dec</sub> )
	1C13:04	SubIndex 004	RW	0x1A03 (6659 <sub>dec</sub> )
1C33:0 [▶ 68]	<b>Subindex</b>	SM input parameter	RO	0x20 (32 <sub>dec</sub> )
	1C33:01	Sync mode	RW	0x0000 (0 <sub>dec</sub> )
	1C33:02	Cycle time	RW	0x000F4240 (1000000 <sub>dec</sub> )
	1C33:03	Shift time	RO	0x00000000 (0 <sub>dec</sub> )
	1C33:04	Sync modes supported	RO	0xC007 (49159 <sub>dec</sub> )
	1C33:05	Minimum cycle time	RO	0x00002710 (10000 <sub>dec</sub> )
	1C33:06	Calc and copy time	RO	0x00000000 (0 <sub>dec</sub> )
	1C33:07	Minimum delay time	RO	0x00000000 (0 <sub>dec</sub> )
	1C33:08	Command	RW	0x0000 (0 <sub>dec</sub> )
	1C33:09	Maximum Delay time	RO	0x00000000 (0 <sub>dec</sub> )
	1C33:0B	SM event missed counter	RO	0x0000 (0 <sub>dec</sub> )
	1C33:0C	Cycle exceeded counter	RO	0x0000 (0 <sub>dec</sub> )
	1C33:0D	Shift too short counter	RO	0x0000 (0 <sub>dec</sub> )
1C33:20	Sync error	RO	0x00 (0 <sub>dec</sub> )	
6000:0 [▶ 69]	<b>Subindex</b>	RTD Inputs Ch.1	RO	0x11 (17 <sub>dec</sub> )
	6000:01	Underrange	RO	0x00 (0 <sub>dec</sub> )
	6000:02	Overrange	RO	0x00 (0 <sub>dec</sub> )
	6000:03	Limit 1	RO	0x00 (0 <sub>dec</sub> )
	6000:05	Limit 2	RO	0x00 (0 <sub>dec</sub> )
	6000:07	Error	RO	0x00 (0 <sub>dec</sub> )
	6000:0E	Sync error	RO	0x00 (0 <sub>dec</sub> )
	6000:0F	TxPDO State	RO	0x00 (0 <sub>dec</sub> )
	6000:10	TxPDO Toggle	RO	0x00 (0 <sub>dec</sub> )
	6000:11	Value	RO	0x0000 (0 <sub>dec</sub> )
	6010:0 [▶ 69]	<b>Subindex</b>	RTD Inputs Ch.2	RO
6010:01		Underrange	RO	0x00 (0 <sub>dec</sub> )
6010:02		Overrange	RO	0x00 (0 <sub>dec</sub> )
6010:03		Limit 1	RO	0x00 (0 <sub>dec</sub> )
6010:05		Limit 2	RO	0x00 (0 <sub>dec</sub> )
6010:07		Error	RO	0x00 (0 <sub>dec</sub> )
6010:0E		Sync error	RO	0x00 (0 <sub>dec</sub> )
6010:0F		TxPDO State	RO	0x00 (0 <sub>dec</sub> )
6010:10		TxPDO Toggle	RO	0x00 (0 <sub>dec</sub> )
6010:11		Value	RO	0x0000 (0 <sub>dec</sub> )

Index (hex)		Name	Flags	Default value
6020:0 [▶ 70]	<b>Subindex</b>	RTD Inputs Ch.3	RO	0x11 (17 <sub>dec</sub> )
	6020:01	Underrange	RO	0x00 (0 <sub>dec</sub> )
	6020:02	Overrange	RO	0x00 (0 <sub>dec</sub> )
	6020:03	Limit 1	RO	0x00 (0 <sub>dec</sub> )
	6020:05	Limit 2	RO	0x00 (0 <sub>dec</sub> )
	6020:07	Error	RO	0x00 (0 <sub>dec</sub> )
	6020:0E	Sync error	RO	0x00 (0 <sub>dec</sub> )
	6020:0F	TxPDO State	RO	0x00 (0 <sub>dec</sub> )
	6020:10	TxPDO Toggle	RO	0x00 (0 <sub>dec</sub> )
6020:11	Value	RO	0x0000 (0 <sub>dec</sub> )	
6030:0 [▶ 70]	<b>Subindex</b>	RTD Inputs Ch.4	RO	0x11 (17 <sub>dec</sub> )
	6030:01	Underrange	RO	0x00 (0 <sub>dec</sub> )
	6030:02	Overrange	RO	0x00 (0 <sub>dec</sub> )
	6030:03	Limit 1	RO	0x00 (0 <sub>dec</sub> )
	6030:05	Limit 2	RO	0x00 (0 <sub>dec</sub> )
	6030:07	Error	RO	0x00 (0 <sub>dec</sub> )
	6030:0E	Sync error	RO	0x00 (0 <sub>dec</sub> )
	6030:0F	TxPDO State	RO	0x00 (0 <sub>dec</sub> )
	6030:10	TxPDO Toggle	RO	0x00 (0 <sub>dec</sub> )
6030:11	Value	RO	0x0000 (0 <sub>dec</sub> )	
8000:0 [▶ 61]	<b>Subindex</b>	RTD Settings Ch.1	RW	0x1B (27 <sub>dec</sub> )
	8000:01	Enable user scale	RW	0x00 (0 <sub>dec</sub> )
	8000:02	Presentation	RW	0x00 (0 <sub>dec</sub> )
	8000:05	Siemens bits	RW	0x00 (0 <sub>dec</sub> )
	8000:06	Enable filter	RW	0x00 (0 <sub>dec</sub> )
	8000:07	Enable limit 1	RW	0x00 (0 <sub>dec</sub> )
	8000:08	Enable limit 2	RW	0x00 (0 <sub>dec</sub> )
	8000:0A	Enable user calibration	RW	0x00 (0 <sub>dec</sub> )
	8000:0B	Enable vendor calibration	RW	0x01 (1 <sub>dec</sub> )
	8000:0E	Swap limit bits	RW	0x00 (0 <sub>dec</sub> )
	8000:11	User scale offset	RW	0x0000 (0 <sub>dec</sub> )
	8000:12	User scale gain	RW	0x00010000 (65536 <sub>dec</sub> )
	8000:13	Limit 1	RW	0x0000 (0 <sub>dec</sub> )
	8000:14	Limit 2	RW	0x0000 (0 <sub>dec</sub> )
	8000:15	Filter settings	RW	0x0000 (0 <sub>dec</sub> )
	8000:16	Calibration interval	RW	0x0000 (0 <sub>dec</sub> )
	8000:17	User calibration offset	RW	0x0000 (0 <sub>dec</sub> )
	8000:18	User calibration gain	RW	0x4000 (16384 <sub>dec</sub> )
	8000:19	RTD element	RW	0x0000 (0 <sub>dec</sub> )
8000:1A	Connection technology	RW	0x0000 (0 <sub>dec</sub> )	
8000:1B	Wire calibration 1/32 Ohm	RW	0x0000 (0 <sub>dec</sub> )	
800E:0 [▶ 71]	<b>Subindex</b>	RTD Internal data Ch.1	RO	0x04 (4 <sub>dec</sub> )
	800E:01	ADC raw value 1	RO	0x00000000 (0 <sub>dec</sub> )
	800E:02	Resistor 1	RO	0x0000 (0 <sub>dec</sub> )
	800E:03	ADC raw value 2	RO	0x00000000 (0 <sub>dec</sub> )
	800E:04	Resistor 2	RO	0x0000 (0 <sub>dec</sub> )
800F:0 [▶ 71]	<b>Subindex</b>	RTD Vendor data Ch.1	RW	0x07 (7 <sub>dec</sub> )
	800F:01	Calibration offset 3-wire	RW	0x0000 (0 <sub>dec</sub> )
	800F:02	Calibration gain 3-wire	RW	0x4000 (16384 <sub>dec</sub> )
	800F:03	Calibration offset 2-wire	RW	0x0000 (0 <sub>dec</sub> )
	800F:04	Calibration gain 2-wire	RW	0x4000 (16384 <sub>dec</sub> )
	800F:05	Calibration offset 4-wire	RW	0x0000 (0 <sub>dec</sub> )
	800F:06	Calibration gain 4-wire	RW	0x4000 (16384 <sub>dec</sub> )
800F:07	PGA Gain Correction	RW	0x0000 (0 <sub>dec</sub> )	



Index (hex)		Name	Flags	Default value
8010:0 [▶ 62]	<b>Subindex</b>	RTD Settings Ch.2	RW	0x1B (27 <sub>dec</sub> )
	8010:01	Enable user scale	RW	0x00 (0 <sub>dec</sub> )
	8010:02	Presentation	RW	0x00 (0 <sub>dec</sub> )
	8010:05	Siemens bits	RW	0x00 (0 <sub>dec</sub> )
	8010:06	Enable filter	RW	0x00 (0 <sub>dec</sub> )
	8010:07	Enable limit 1	RW	0x00 (0 <sub>dec</sub> )
	8010:08	Enable limit 2	RW	0x00 (0 <sub>dec</sub> )
	8010:0A	Enable user calibration	RW	0x00 (0 <sub>dec</sub> )
	8010:0B	Enable vendor calibration	RW	0x01 (1 <sub>dec</sub> )
	8010:0E	Swap limit bits	RW	0x00 (0 <sub>dec</sub> )
	8010:11	User scale offset	RW	0x0000 (0 <sub>dec</sub> )
	8010:12	User scale gain	RW	0x00010000 (65536 <sub>dec</sub> )
	8010:13	Limit 1	RW	0x0000 (0 <sub>dec</sub> )
	8010:14	Limit 2	RW	0x0000 (0 <sub>dec</sub> )
	8010:15	Filter settings	RW	0x0000 (0 <sub>dec</sub> )
	8010:16	Calibration interval	RW	0x0000 (0 <sub>dec</sub> )
	8010:17	User calibration offset	RW	0x0000 (0 <sub>dec</sub> )
	8010:18	User calibration gain	RW	0x4000 (16384 <sub>dec</sub> )
	8010:19	RTD element	RW	0x0000 (0 <sub>dec</sub> )
	8010:1A	Connection technology	RW	0x0000 (0 <sub>dec</sub> )
8010:1B	Wire calibration 1/32 Ohm	RW	0x0000 (0 <sub>dec</sub> )	
801E:0 [▶ 71]	<b>Subindex</b>	RTD Internal data Ch.2	RO	0x04 (4 <sub>dec</sub> )
	801E:01	ADC raw value 1	RO	0x00000000 (0 <sub>dec</sub> )
	801E:02	Resistor 1	RO	0x0000 (0 <sub>dec</sub> )
	801E:03	ADC raw value 2	RO	0x00000000 (0 <sub>dec</sub> )
	801E:04	Resistor 2	RO	0x0000 (0 <sub>dec</sub> )
801F [▶ 71]	<b>Subindex</b>	RTD Vendor data Ch.2	RW	0x07 (7 <sub>dec</sub> )
	801F:01	Calibration offset 3-wire	RW	0x0000 (0 <sub>dec</sub> )
	801F:02	Calibration gain 3-wire	RW	0x4000 (16384 <sub>dec</sub> )
	801F:03	Calibration offset 2-wire	RW	0x0000 (0 <sub>dec</sub> )
	801F:04	Calibration gain 2-wire	RW	0x4000 (16384 <sub>dec</sub> )
	801F:05	Calibration offset 4-wire	RW	0x0000 (0 <sub>dec</sub> )
	801F:06	Calibration gain 4-wire	RW	0x4000 (16384 <sub>dec</sub> )
	801F:07	PGA Gain Correction	RW	0x0000 (0 <sub>dec</sub> )
8020:0 [▶ 63]	<b>Subindex</b>	RTD Settings Ch.3	RW	0x1B (27 <sub>dec</sub> )
	8020:01	Enable user scale	RW	0x00 (0 <sub>dec</sub> )
	8020:02	Presentation	RW	0x00 (0 <sub>dec</sub> )
	8020:05	Siemens bits	RW	0x00 (0 <sub>dec</sub> )
	8020:06	Enable filter	RW	0x00 (0 <sub>dec</sub> )
	8020:07	Enable limit 1	RW	0x00 (0 <sub>dec</sub> )
	8020:08	Enable limit 2	RW	0x00 (0 <sub>dec</sub> )
	8020:0A	Enable user calibration	RW	0x00 (0 <sub>dec</sub> )
	8020:0B	Enable vendor calibration	RW	0x01 (1 <sub>dec</sub> )
	8020:0E	Swap limit bits	RW	0x00 (0 <sub>dec</sub> )
	8020:11	User scale offset	RW	0x0000 (0 <sub>dec</sub> )
	8020:12	User scale gain	RW	0x00010000 (65536 <sub>dec</sub> )
	8020:13	Limit 1	RW	0x0000 (0 <sub>dec</sub> )
	8020:14	Limit 2	RW	0x0000 (0 <sub>dec</sub> )
	8020:15	Filter settings	RW	0x0000 (0 <sub>dec</sub> )
	8020:16	Calibration interval	RW	0x0000 (0 <sub>dec</sub> )
	8020:17	User calibration offset	RW	0x0000 (0 <sub>dec</sub> )
	8020:18	User calibration gain	RW	0x4000 (16384 <sub>dec</sub> )
	8020:19	RTD element	RW	0x0000 (0 <sub>dec</sub> )
	8020:1A	Connection technology	RW	0x0000 (0 <sub>dec</sub> )
8020:1B	Wire calibration 1/32 Ohm	RW	0x0000 (0 <sub>dec</sub> )	

Index (hex)		Name	Flags	Default value
802E:0 [▶ 72]	<b>Subindex</b>	RTD Internal data Ch.3	RO	0x04 (4 <sub>dec</sub> )
	802E:01	ADC raw value 1	RO	0x00000000 (0 <sub>dec</sub> )
	802E:02	Resistor 1	RO	0x0000 (0 <sub>dec</sub> )
	802E:03	ADC raw value 2	RO	0x00000000 (0 <sub>dec</sub> )
	802E:04	Resistor 2	RO	0x0000 (0 <sub>dec</sub> )
802F:0 [▶ 72]	<b>Subindex</b>	RTD Vendor data Ch.3	RW	0x07 (7 <sub>dec</sub> )
	802F:01	Calibration offset 3-wire	RW	0x0000 (0 <sub>dec</sub> )
	802F:02	Calibration gain 3-wire	RW	0x4000 (16384 <sub>dec</sub> )
	802F:03	Calibration offset 2-wire	RW	0x0000 (0 <sub>dec</sub> )
	802F:04	Calibration gain 2-wire	RW	0x4000 (16384 <sub>dec</sub> )
	802F:05	Calibration offset 4-wire	RW	0x0000 (0 <sub>dec</sub> )
	802F:06	Calibration gain 4-wire	RW	0x4000 (16384 <sub>dec</sub> )
	802F:07	PGA Gain Correction	RW	0x0000 (0 <sub>dec</sub> )
8030:0 [▶ 64]	<b>Subindex</b>	RTD Settings Ch.4	RW	0x1B (27 <sub>dec</sub> )
	8030:01	Enable user scale	RW	0x00 (0 <sub>dec</sub> )
	8030:02	Presentation	RW	0x00 (0 <sub>dec</sub> )
	8030:05	Siemens bits	RW	0x00 (0 <sub>dec</sub> )
	8030:06	Enable filter	RW	0x00 (0 <sub>dec</sub> )
	8030:07	Enable limit 1	RW	0x00 (0 <sub>dec</sub> )
	8030:08	Enable limit 2	RW	0x00 (0 <sub>dec</sub> )
	8030:0A	Enable user calibration	RW	0x00 (0 <sub>dec</sub> )
	8030:0B	Enable vendor calibration	RW	0x01 (1 <sub>dec</sub> )
	8030:0E	Swap limit bits	RW	0x00 (0 <sub>dec</sub> )
	8030:11	User scale offset	RW	0x0000 (0 <sub>dec</sub> )
	8030:12	User scale gain	RW	0x00010000 (65536 <sub>dec</sub> )
	8030:13	Limit 1	RW	0x0000 (0 <sub>dec</sub> )
	8030:14	Limit 2	RW	0x0000 (0 <sub>dec</sub> )
	8030:15	Filter settings	RW	0x0000 (0 <sub>dec</sub> )
	8030:16	Calibration interval	RW	0x0000 (0 <sub>dec</sub> )
	8030:17	User calibration offset	RW	0x0000 (0 <sub>dec</sub> )
	8030:18	User calibration gain	RW	0x4000 (16384 <sub>dec</sub> )
	8030:19	RTD element	RW	0x0000 (0 <sub>dec</sub> )
	8030:1A	Connection technology	RW	0x0000 (0 <sub>dec</sub> )
8030:1B	Wire calibration 1/32 Ohm	RW	0x0000 (0 <sub>dec</sub> )	
803E:0 [▶ 72]	<b>Subindex</b>	RTD Internal data Ch.4	RO	0x04 (4 <sub>dec</sub> )
	803E:01	ADC raw value 1	RO	0x00000000 (0 <sub>dec</sub> )
	803E:02	Resistor 1	RO	0x0000 (0 <sub>dec</sub> )
	803E:03	ADC raw value 2	RO	0x00000000 (0 <sub>dec</sub> )
	803E:04	Resistor 2	RO	0x0000 (0 <sub>dec</sub> )
803F:0 [▶ 72]	<b>Subindex</b>	RTD Vendor data Ch.4	RW	0x07 (7 <sub>dec</sub> )
	803F:01	Calibration offset 3-wire	RW	0x0000 (0 <sub>dec</sub> )
	803F:02	Calibration gain 3-wire	RW	0x4000 (16384 <sub>dec</sub> )
	803F:03	Calibration offset 2-wire	RW	0x0000 (0 <sub>dec</sub> )
	803F:04	Calibration gain 2-wire	RW	0x4000 (16384 <sub>dec</sub> )
	803F:05	Calibration offset 4-wire	RW	0x0000 (0 <sub>dec</sub> )
	803F:06	Calibration gain 4-wire	RW	0x4000 (16384 <sub>dec</sub> )
	803F:07	PGA Gain Correction	RW	0x0000 (0 <sub>dec</sub> )
F000:0 [▶ 73]	<b>Subindex</b>	Modular device profile	RO	0x02 (2 <sub>dec</sub> )
	F000:01	Module index distance	RO	0x0010 (16 <sub>dec</sub> )
	F000:02	Maximum number of modules	RO	0x0004 (4 <sub>dec</sub> )
F008 [▶ 73]		Code word	RW	0x00000000 (0 <sub>dec</sub> )
F010:0 [▶ 73]	<b>Subindex</b>	Module list	RW	0x04 (4 <sub>dec</sub> )
	F010:01	SubIndex 001	RW	0x00000140 (320 <sub>dec</sub> )
	F010:02	SubIndex 002	RW	0x00000140 (320 <sub>dec</sub> )
	F010:03	SubIndex 003	RW	0x00000140 (320 <sub>dec</sub> )
	F010:04	SubIndex 004	RW	0x00000140 (320 <sub>dec</sub> )

Index (hex)		Name	Flags	Default value
F080:0 [▶ 73]	<b>Subindex</b>	Channel Enable	RO	0x04 (4 <sub>dec</sub> )
	F080:01	SubIndex 001	RW	0xFF (255 <sub>dec</sub> )
	F080:02	SubIndex 002	RW	0xFF (255 <sub>dec</sub> )
	F080:03	SubIndex 003	RW	0xFF (255 <sub>dec</sub> )
	F080:04	SubIndex 004	RW	0xFF (255 <sub>dec</sub> )

**Key**

Flags:

RO (Read Only): this object can be read only

RW (Read/Write): this object can be read and written to

## 7.4 EP3204 - object description and parameterization

### ● EtherCAT XML Device Description



The display matches that of the CoE objects from the EtherCAT XML Device Description. We recommend downloading the latest XML file from the download area of the Beckhoff website and installing it according to installation instructions.

### ● Parameterization via the CoE list (CAN over EtherCAT)



The EtherCAT device is parameterized via the CoE - Online tab (double-click on the respective object) or via the Process Data tab (allocation of PDOs).

### Introduction

The CoE overview contains objects for different intended applications:

- Objects required for parameterization [▶ 60] during commissioning
- Objects intended for regular operation [▶ 65], e.g. through ADS access.
- Objects for indicating internal settings [▶ 66] (may be fixed)
- Further profile-specific objects [▶ 69] indicating inputs, outputs and status information

The following section first describes the objects required for normal operation, followed by a complete overview of missing objects.

### 7.4.1 Objects to be parameterized during commissioning

#### Index 1011: Restore default parameters

Index (hex)	Name	Meaning	Data type	Flags	Default
1011:0	Restore default parameters	Restore default parameters	UINT8	RO	0x01 (1 <sub>dec</sub> )
1011:01	SubIndex 001	If this object is set to " <b>0x64616F6C</b> " in the set value dialog, all backup objects are reset to their delivery state.	UINT32	RW	0x00000000 (0 <sub>dec</sub> )

**Index 8000: RTD Settings Ch.1**

Index (hex)	Name	Meaning	Data type	Flags	Default	
8000:0	RTD Settings Ch.1	Maximum subindex	UINT8	RO	0x1B (27 <sub>dec</sub> )	
8000:01	Enable user scale	Activates user scaling	BOOLEAN	RW	0x00 (0 <sub>dec</sub> )	
8000:02	Presentation	Presentation of the measured value		BIT3	RW	0x00 (0 <sub>dec</sub> )
		0	Signed, in two's complement			
		1	Most significant bit as sign			
		2	High-resolution (1/100 °C steps)			
8000:05	Siemens bits	The S5 bits are displayed in the three low-order bits	BOOLEAN	RW	0x00 (0 <sub>dec</sub> )	
8000:06	Enable filter	Enable filter, which makes PLC-cycle-synchronous data exchange unnecessary	BOOLEAN	RW	0x00 (0 <sub>dec</sub> )	
8000:07	Enable limit 1	Activates limit check for limit 1	BOOLEAN	RW	0x00 (0 <sub>dec</sub> )	
8000:08	Enable limit 2	Activates limit check for limit 2	BOOLEAN	RW	0x00 (0 <sub>dec</sub> )	
8000:0A	Enable user calibration	Activates user calibration	BOOLEAN	RW	0x00 (0 <sub>dec</sub> )	
8000:0B	Enable vendor calibration	Activates vendor calibration	BOOLEAN	RW	0x01 (1 <sub>dec</sub> )	
8000:0E	Swap limit bits	Swaps the two limit bits, in order to achieve compatibility with older hardware versions.	BOOLEAN	RW	0x00 (0 <sub>dec</sub> )	
8000:11	User scale offset	User scaling offset	INT16	RW	0x0000 (0 <sub>dec</sub> )	
8000:12	User scale gain	Gain of the user scaling	INT32	RW	0x00010000 (65536 <sub>dec</sub> )	
8000:13	Limit 1	Value for limit 1	INT16	RW	0x0000 (0 <sub>dec</sub> )	
8000:14	Limit 2	Value for limit 2	INT16	RW	0x0000 (0 <sub>dec</sub> )	
8000:15	Filter settings	Filter settings		UINT16	RW	0x0000 (0 <sub>dec</sub> )
		0	50 Hz			
		1	60 Hz			
		2	100 Hz			
		3	500 Hz			
		4	1 kHz			
		5	2 kHz			
		6	3.75 kHz			
		7	7.5 kHz			
		8	15 kHz			
		9	30 kHz			
		10	5 Hz			
		11	10 Hz			
8000:16	Calibration interval	reserved	UINT16	RW	0x0000 (0 <sub>dec</sub> )	
8000:17	User calibration offset	User calibration offset	INT16	RW	0x0000 (0 <sub>dec</sub> )	
8000:18	User calibration gain	Gain of the user calibration	UINT16	RW	0x4000 (16384 <sub>dec</sub> )	
8000:19	RTD element	Sensor type		UINT16	RW	0x0000 (0 <sub>dec</sub> )
		0	Pt100			
		1	Ni100			
		2	Pt1000			
		3	Pt500			
		4	Pt200			
		5	Ni1000			
		6	Ni1000 (Siemens)			
		7	Ni120			
		8	Resistance measurement with 1/16 ohm resolution			
9	Resistance measurement with 1/64 ohm resolution					

## Index 8000: RTD Settings Ch.1

Index (hex)	Name	Meaning	Data type	Flags	Default	
8000:1A	Connection technology	Connection technology:	UINT16	RW	0x0000 (0 <sub>dec</sub> )	
		0				2-wire
		1				3-wire
		2				4-wire
3	No sensor connected (only supported by hardware version 00): This setting skips the whole measurement, thus speeding up the data acquisition for the other channels. The green status LED of the respective channel remains lit. The error bit of a deactivated channel is canceled and no longer set.					
8000:1B	Wire calibration 1/32 Ohm	Only for 2-wire measurements: contains the resistance of the supply line for the temperature sensor (in 1/32 ohm).	INT16	RW	0x0000 (0 <sub>dec</sub> )	

## Index 8010: RTD Settings Ch.2

Index (hex)	Name	Meaning	Data type	Flags	Default	
8010:0	RTD Settings Ch.2	Maximum subindex	UINT8	RO	0x1B (27 <sub>dec</sub> )	
8010:01	Enable user scale	Activates user scaling	BOOLEAN	RW	0x00 (0 <sub>dec</sub> )	
8010:02	Presentation	Presentation of the measured value	BIT3	RW	0x00 (0 <sub>dec</sub> )	
		0				Signed, in two's complement
		1				Most significant bit as sign
2	High-resolution (1/100 °C steps)					
8010:05	Siemens bits	The S5 bits are displayed in the three low-order bits	BOOLEAN	RW	0x00 (0 <sub>dec</sub> )	
8010:06	Enable filter	Enable filter, which makes PLC-cycle-synchronous data exchange unnecessary	BOOLEAN	RW	0x00 (0 <sub>dec</sub> )	
8010:07	Enable limit 1	Activates limit check for limit 1	BOOLEAN	RW	0x00 (0 <sub>dec</sub> )	
8010:08	Enable limit 2	Activates limit check for limit 2	BOOLEAN	RW	0x00 (0 <sub>dec</sub> )	
8010:0A	Enable user calibration	Activates user calibration	BOOLEAN	RW	0x00 (0 <sub>dec</sub> )	
8010:0B	Enable vendor calibration	Activates manufacturer calibration	BOOLEAN	RW	0x01 (1 <sub>dec</sub> )	
8010:0E	Swap limit bits	Swaps the two limit bits, in order to achieve compatibility with older hardware versions.	BOOLEAN	RW	0x00 (0 <sub>dec</sub> )	
8010:11	User scale offset	User scaling offset	INT16	RW	0x0000 (0 <sub>dec</sub> )	
8010:12	User scale gain	Gain of the user scaling	INT32	RW	0x00010000 (65536 <sub>dec</sub> )	
8010:13	Limit 1	Value for limit 1	INT16	RW	0x0000 (0 <sub>dec</sub> )	
8010:14	Limit 2	Value for limit 2	INT16	RW	0x0000 (0 <sub>dec</sub> )	
8010:15	Filter settings	Filter settings	UINT16	RW	0x0000 (0 <sub>dec</sub> )	
		0				50 Hz
		1				60 Hz
		2				100 Hz
		3				500 Hz
		4				1 kHz,
		5				2 kHz
		6				3.75 kHz
		7				7.5 kHz
		8				15 kHz
		9				30 kHz
		10				5 Hz
11	10 Hz					
8010:16	Calibration interval	reserved	UINT16	RW	0x0000 (0 <sub>dec</sub> )	
8010:17	User calibration offset	User calibration offset	INT16	RW	0x0000 (0 <sub>dec</sub> )	
8010:18	User calibration gain	Gain of the user calibration	UINT16	RW	0x4000 (16384 <sub>dec</sub> )	

**Index 8010: RTD Settings Ch.2**

Index (hex)	Name	Meaning	Data type	Flags	Default	
8010:19	RTD element	Sensor type	UINT16	RW	0x0000 (0 <sub>dec</sub> )	
		0				Pt100
		1				Ni100
		2				Pt1000
		3				Pt500
		4				Pt200
		5				Ni1000
		6				Ni1000 (Siemens)
		7				Ni120
		8				Resistance measurement with 1/16 ohm resolution
9	Resistance measurement with 1/64 ohm resolution					
8010:1A	Connection technology	Connection technology:	UINT16	RW	0x0000 (0 <sub>dec</sub> )	
		0				2-wire
		1				3-wire
		2				4-wire
3	No sensor connected (only supported by hardware version 00): This setting skips the whole measurement, thus speeding up the data acquisition for the other channels. The green status LED of the respective channel remains lit. The error bit of a deactivated channel is cancelled and no longer set.					
8010:1B	Wire calibration 1/32 Ohm	Only for 2-wire measurements: contains the resistance of the supply line for the temperature sensor (in 1/32 ohm).	INT16	RW	0x0000 (0 <sub>dec</sub> )	

**Index 8020: RTD Settings Ch.3**

Index (hex)	Name	Meaning	Data type	Flags	Default	
8020:0	RTD Settings Ch.3	Maximum subindex	UINT8	RO	0x1B (27 <sub>dec</sub> )	
8020:01	Enable user scale	Activates user scaling	BOOLEAN	RW	0x00 (0 <sub>dec</sub> )	
8020:02	Presentation	Presentation of the measured value	BIT3	RW	0x00 (0 <sub>dec</sub> )	
		0				Signed, in two's complement
		1				Most significant bit as sign
2	High-resolution (1/100 °C steps)					
8020:05	Siemens bits	The S5 bits are displayed in the three low-order bits	BOOLEAN	RW	0x00 (0 <sub>dec</sub> )	
8020:06	Enable filter	Enable filter, which makes PLC-cycle-synchronous data exchange unnecessary	BOOLEAN	RW	0x00 (0 <sub>dec</sub> )	
8020:07	Enable limit 1	Activates limit check for limit 1	BOOLEAN	RW	0x00 (0 <sub>dec</sub> )	
8020:08	Enable limit 2	Activates limit check for limit 2	BOOLEAN	RW	0x00 (0 <sub>dec</sub> )	
8020:0A	Enable user calibration	Activates user calibration	BOOLEAN	RW	0x00 (0 <sub>dec</sub> )	
8020:0B	Enable vendor calibration	Activates vendor calibration	BOOLEAN	RW	0x01 (1 <sub>dec</sub> )	
8020:0E	Swap limit bits	Swaps the two limit bits, in order to achieve compatibility with older hardware versions.	BOOLEAN	RW	0x00 (0 <sub>dec</sub> )	
8020:11	User scale offset	User scaling offset	INT16	RW	0x0000 (0 <sub>dec</sub> )	
8020:12	User scale gain	Gain of the user scaling	INT32	RW	0x00010000 (65536 <sub>dec</sub> )	
8020:13	Limit 1	Value for limit 1	INT16	RW	0x0000 (0 <sub>dec</sub> )	
8020:14	Limit 2	Value for limit 2	INT16	RW	0x0000 (0 <sub>dec</sub> )	

## Index 8020: RTD Settings Ch.3

Index (hex)	Name	Meaning	Data type	Flags	Default	
8020:15	Filter settings	Filter settings	UINT16	RW	0x0000 (0 <sub>dec</sub> )	
		0				50 Hz
		1				60 Hz
		2				100 Hz
		3				500 Hz
		4				1 kHz,
		5				2 kHz
		6				3.75 kHz
		7				7.5 kHz
		8				15 kHz
		9				30 kHz
		10				5 Hz
11	10 Hz					
8020:16	Calibration interval	reserved	UINT16	RW	0x0000 (0 <sub>dec</sub> )	
8020:17	User calibration offset	User calibration offset	INT16	RW	0x0000 (0 <sub>dec</sub> )	
8020:18	User calibration gain	Gain of the user calibration	UINT16	RW	0x4000 (16384 <sub>dec</sub> )	
8020:19	RTD element	Sensor type	UINT16	RW	0x0000 (0 <sub>dec</sub> )	
		0				Pt100
		1				Ni100
		2				Pt1000
		3				Pt500
		4				Pt200
		5				Ni1000
		6				Ni1000 (Siemens)
		7				Ni120
		8				Resistance measurement with 1/16 ohm resolution
9	Resistance measurement with 1/64 ohm resolution					
8020:1A	Connection technology	Connection technology:	UINT16	RW	0x0000 (0 <sub>dec</sub> )	
		0				2-wire
		1				3-wire
		2				4-wire
		3				No sensor connected (only supported by hardware version 00): This setting skips the whole measurement, thus speeding up the data acquisition for the other channels. The green status LED of the respective channel remains lit. The error bit of a deactivated channel is canceled and no longer set.
8020:1B	Wire calibration 1/32 Ohm	Only for 2-wire measurements: contains the resistance of the supply line for the temperature sensor (in 1/32 ohm).	INT16	RW	0x0000 (0 <sub>dec</sub> )	

## Index 8030: RTD Settings Ch.4

Index (hex)	Name	Meaning	Data type	Flags	Default	
8030:0	RTD Settings Ch.4	Maximum subindex	UINT8	RO	0x1B (27 <sub>dec</sub> )	
8030:01	Enable user scale	Activates user scaling	BOOLEAN	RW	0x00 (0 <sub>dec</sub> )	
8030:02	Presentation	Presentation of the measured value	BIT3	RW	0x00 (0 <sub>dec</sub> )	
		0				Signed, in two's complement
		1				Most significant bit as sign
2	High-resolution (1/100 °C steps)					
8030:05	Siemens bits	The S5 bits are displayed in the three low-order bits	BOOLEAN	RW	0x00 (0 <sub>dec</sub> )	
8030:06	Enable filter	Enable filter, which makes PLC-cycle-synchronous data exchange unnecessary	BOOLEAN	RW	0x00 (0 <sub>dec</sub> )	
8030:07	Enable limit 1	Activates limit check for limit 1	BOOLEAN	RW	0x00 (0 <sub>dec</sub> )	
8030:08	Enable limit 2	Activates limit check for limit 2	BOOLEAN	RW	0x00 (0 <sub>dec</sub> )	



**Index 8030: RTD Settings Ch.4**

Index (hex)	Name	Meaning	Data type	Flags	Default																								
8030:0A	Enable user calibration	Activates user calibration	BOOLEAN	RW	0x00 (0 <sub>dec</sub> )																								
8030:0B	Enable vendor calibration	Activates vendor calibration	BOOLEAN	RW	0x01 (1 <sub>dec</sub> )																								
8030:0E	Swap limit bits	Swaps the two limit bits, in order to achieve compatibility with older hardware versions.	BOOLEAN	RW	0x00 (0 <sub>dec</sub> )																								
8030:11	User scale offset	User scaling offset	INT16	RW	0x0000 (0 <sub>dec</sub> )																								
8030:12	User scale gain	Gain of the user scaling	INT32	RW	0x00010000 (65536 <sub>dec</sub> )																								
8030:13	Limit 1	Value for limit 1	INT16	RW	0x0000 (0 <sub>dec</sub> )																								
8030:14	Limit 2	Value for limit 2	INT16	RW	0x0000 (0 <sub>dec</sub> )																								
8030:15	Filter settings	Filter settings <table border="1" style="width: 100%; border-collapse: collapse;"> <tr><td>0</td><td>50 Hz</td></tr> <tr><td>1</td><td>60 Hz</td></tr> <tr><td>2</td><td>100 Hz</td></tr> <tr><td>3</td><td>500 Hz</td></tr> <tr><td>4</td><td>1 kHz,</td></tr> <tr><td>5</td><td>2 kHz</td></tr> <tr><td>6</td><td>3.75 kHz</td></tr> <tr><td>7</td><td>7.5 kHz</td></tr> <tr><td>8</td><td>15 kHz</td></tr> <tr><td>9</td><td>30 kHz</td></tr> <tr><td>10</td><td>5 Hz</td></tr> <tr><td>11</td><td>10 Hz</td></tr> </table>	0	50 Hz	1	60 Hz	2	100 Hz	3	500 Hz	4	1 kHz,	5	2 kHz	6	3.75 kHz	7	7.5 kHz	8	15 kHz	9	30 kHz	10	5 Hz	11	10 Hz	UINT16	RW	0x0000 (0 <sub>dec</sub> )
0	50 Hz																												
1	60 Hz																												
2	100 Hz																												
3	500 Hz																												
4	1 kHz,																												
5	2 kHz																												
6	3.75 kHz																												
7	7.5 kHz																												
8	15 kHz																												
9	30 kHz																												
10	5 Hz																												
11	10 Hz																												
8030:16	Calibration interval	reserved	UINT16	RW	0x0000 (0 <sub>dec</sub> )																								
8030:17	User calibration offset	User calibration offset	INT16	RW	0x0000 (0 <sub>dec</sub> )																								
8030:18	User calibration gain	Gain of the user calibration	UINT16	RW	0x4000 (16384 <sub>dec</sub> )																								
8030:19	RTD element	Sensor type <table border="1" style="width: 100%; border-collapse: collapse;"> <tr><td>0</td><td>Pt100</td></tr> <tr><td>1</td><td>Ni100</td></tr> <tr><td>2</td><td>Pt1000</td></tr> <tr><td>3</td><td>Pt500</td></tr> <tr><td>4</td><td>Pt200</td></tr> <tr><td>5</td><td>Ni1000</td></tr> <tr><td>6</td><td>Ni1000 (Siemens)</td></tr> <tr><td>7</td><td>Ni120</td></tr> <tr><td>8</td><td>Resistance measurement with 1/16 ohm resolution</td></tr> <tr><td>9</td><td>Resistance measurement with 1/64 ohm resolution</td></tr> </table>	0	Pt100	1	Ni100	2	Pt1000	3	Pt500	4	Pt200	5	Ni1000	6	Ni1000 (Siemens)	7	Ni120	8	Resistance measurement with 1/16 ohm resolution	9	Resistance measurement with 1/64 ohm resolution	UINT16	RW	0x0000 (0 <sub>dec</sub> )				
0	Pt100																												
1	Ni100																												
2	Pt1000																												
3	Pt500																												
4	Pt200																												
5	Ni1000																												
6	Ni1000 (Siemens)																												
7	Ni120																												
8	Resistance measurement with 1/16 ohm resolution																												
9	Resistance measurement with 1/64 ohm resolution																												
8030:1A	Connection technology	Connection technology: <table border="1" style="width: 100%; border-collapse: collapse;"> <tr><td>0</td><td>2-wire</td></tr> <tr><td>1</td><td>3-wire</td></tr> <tr><td>2</td><td>4-wire</td></tr> <tr><td>3</td><td>No sensor connected (only supported by hardware version 00): This setting skips the whole measurement, thus speeding up the data acquisition for the other channels. The green status LED of the respective channel remains lit. The error bit of a deactivated channel is canceled and no longer set.</td></tr> </table>	0	2-wire	1	3-wire	2	4-wire	3	No sensor connected (only supported by hardware version 00): This setting skips the whole measurement, thus speeding up the data acquisition for the other channels. The green status LED of the respective channel remains lit. The error bit of a deactivated channel is canceled and no longer set.	UINT16	RW	0x0000 (0 <sub>dec</sub> )																
0	2-wire																												
1	3-wire																												
2	4-wire																												
3	No sensor connected (only supported by hardware version 00): This setting skips the whole measurement, thus speeding up the data acquisition for the other channels. The green status LED of the respective channel remains lit. The error bit of a deactivated channel is canceled and no longer set.																												
8030:1B	Wire calibration 1/32 Ohm	Only for 2-wire measurements: contains the resistance of the supply line for the temperature sensor (in 1/32 ohm).	INT16	RW	0x0000 (0 <sub>dec</sub> )																								

**7.4.2 Objects for regular operation**

EPP3204 has no such objects.

### 7.4.3 Standard objects (0x1000-0x1FFF)

The standard objects have the same meaning for all EtherCAT slaves.

#### Index 1000: Device type

Index (hex)	Name	Meaning	Data type	Flags	Default
1000:0	Device type	Device type of the EtherCAT slave: The Low-Word contains the CoE profile used (5001). The High-Word contains the module profile according to the modular device profile.	UINT32	RO	0x01401389 (20976521 <sub>dec</sub> )

#### Index 1008: Device name

Index (hex)	Name	Meaning	Data type	Flags	Default
1008:0	Device name	Device name of the EtherCAT slave	STRING	RO	EP3204-0002

#### Index 1009: Hardware version

Index (hex)	Name	Meaning	Data type	Flags	Default
1009:0	Hardware version	Hardware version of the EtherCAT slave	STRING	RO	05

#### Index 100A: Software version

Index (hex)	Name	Meaning	Data type	Flags	Default
100A:0	Software version	Firmware version of the EtherCAT slave	STRING	RO	07

#### Index 1018: Identity

Index (hex)	Name	Meaning	Data type	Flags	Default
1018:0	Identity	Information for identifying the slave	UINT8	RO	0x04 (4 <sub>dec</sub> )
1018:01	Vendor ID	Vendor ID of the EtherCAT slave	UINT32	RO	0x00000002 (2 <sub>dec</sub> )
1018:02	Product code	Product code of the EtherCAT slave	UINT32	RO	0x0C844052 (209993810 <sub>dec</sub> )
1018:03	Revision	Revision number of the EtherCAT slave; the low word (bit 0-15) indicates the special terminal number, the high word (bit 16-31) refers to the device description	UINT32	RO	0x00120002 (1179650 <sub>dec</sub> )
1018:04	Serial number	Serial number of the EtherCAT slave; the low byte (bit 0-7) of the low word contains the year of production, the high byte (bit 8-15) of the low word contains the week of production, the high word (bit 16-31) is 0	UINT32	RO	0x00000000 (0 <sub>dec</sub> )

#### Index 10F0: Backup parameter handling

Index (hex)	Name	Meaning	Data type	Flags	Default
10F0:0	Backup parameter handling	Information for standardized loading and saving of backup entries	UINT8	RO	0x01 (1 <sub>dec</sub> )
10F0:01	Checksum	Checksum across all backup entries of the EtherCAT slave	UINT32	RO	0x00000000 (0 <sub>dec</sub> )

**Index 1A00: RTD TxPDO-Map RTDInputs Ch.1**

Index (hex)	Name	Meaning	Data type	Flags	Default
1A00:0	RTD TxPDO-Map RT-DInputs Ch.1	PDO Mapping TxPDO 1	UINT8	RO	0x09 (9 <sub>dez</sub> )
1A00:01	SubIndex 001	1. PDO Mapping entry	UINT32	RO	0x6000:01, 1
1A00:02	SubIndex 002	2. PDO Mapping entry	UINT32	RO	0x6000:02, 1
1A00:03	SubIndex 003	3. PDO Mapping entry	UINT32	RO	0x6000:03, 2
1A00:04	SubIndex 004	4. PDO Mapping entry	UINT32	RO	0x6000:05, 2
1A00:05	SubIndex 005	5. PDO Mapping entry	UINT32	RO	0x6000:07, 1
1A00:06	SubIndex 006	6. PDO Mapping entry (7 bits align)	UINT32	RO	0x0000:00, 7
1A00:07	SubIndex 007	7. PDO Mapping entry	UINT32	RO	0x6000:0, 1
1A00:08	SubIndex 008	8. PDO Mapping entry	UINT32	RO	0x6000:10, 1
1A00:09	SubIndex 009	9. PDO Mapping entry	UINT32	RO	0x6000:11, 16

**Index 1A01: RTD TxPDO-Map RTDInputs Ch.2**

Index (hex)	Name	Meaning	Data type	Flags	Default
1A01:0	RTD TxPDO-Map RT-DInputs Ch.2	PDO Mapping TxPDO 2	UINT8	RO	0x09 (9 <sub>dez</sub> )
1A01:01	SubIndex 001	1. PDO Mapping entry	UINT32	RO	0x6010:01, 1
1A01:02	SubIndex 002	2. PDO Mapping entry	UINT32	RO	0x6010:02, 1
1A01:03	SubIndex 003	3. PDO Mapping entry	UINT32	RO	0x6010:03, 2
1A01:04	SubIndex 004	4. PDO Mapping entry	UINT32	RO	0x6010:05, 2
1A01:05	SubIndex 005	5. PDO Mapping entry	UINT32	RO	0x6010:07, 1
1A01:06	SubIndex 006	6. PDO Mapping entry (7 bits align)	UINT32	RO	0x0000:00, 7
1A01:07	SubIndex 007	7. PDO Mapping entry	UINT32	RO	0x6010:0F, 1
1A01:08	SubIndex 008	8. PDO Mapping entry	UINT32	RO	0x6010:10, 1
1A01:09	SubIndex 009	9. PDO Mapping entry	UINT32	RO	0x6010:11, 16

**Index 1A02: RTD TxPDO-Map RTDInputs Ch.3**

Index (hex)	Name	Meaning	Data type	Flags	Default
1A02:0	RTD TxPDO-Map RT-DInputs Ch.3	PDO Mapping TxPDO 3	UINT8	RO	0x09 (9 <sub>dez</sub> )
1A02:01	SubIndex 001	1. PDO Mapping entry	UINT32	RO	0x6020:01, 1
1A02:02	SubIndex 002	2. PDO Mapping entry	UINT32	RO	0x6020:02, 1
1A02:03	SubIndex 003	3. PDO Mapping entry	UINT32	RO	0x6020:03, 2
1A02:04	SubIndex 004	4. PDO Mapping entry	UINT32	RO	0x6020:05, 2
1A02:05	SubIndex 005	5. PDO Mapping entry	UINT32	RO	0x6020:07, 1
1A02:06	SubIndex 006	6. PDO Mapping entry (7 bits align)	UINT32	RO	0x0000:00, 7
1A02:07	SubIndex 007	7. PDO Mapping entry	UINT32	RO	0x6020:0F, 1
1A02:08	SubIndex 008	8. PDO Mapping entry	UINT32	RO	0x6020:10, 1
1A02:09	SubIndex 009	9. PDO Mapping entry	UINT32	RO	0x6020:11, 16

**Index 1A03: RTD TxPDO-Map RTDInputs Ch.4**

Index (hex)	Name	Meaning	Data type	Flags	Default
1A03:0	RTD TxPDO-Map RT-DInputs Ch.4	PDO Mapping TxPDO 4	UINT8	RO	0x09 (9 <sub>dez</sub> )
1A03:01	SubIndex 001	1. PDO Mapping entry	UINT32	RO	0x6030:01, 1
1A03:02	SubIndex 002	2. PDO Mapping entry	UINT32	RO	0x6030:02, 1
1A03:03	SubIndex 003	3. PDO Mapping entry	UINT32	RO	0x6030:03, 2
1A03:04	SubIndex 004	4. PDO Mapping entry	UINT32	RO	0x6030:05, 2
1A03:05	SubIndex 005	5. PDO Mapping entry	UINT32	RO	0x6030:07, 1
1A03:06	SubIndex 006	6. PDO Mapping entry (7 bits align)	UINT32	RO	0x0000:00, 7
1A03:07	SubIndex 007	7. PDO Mapping entry	UINT32	RO	0x6030:0F, 1
1A03:08	SubIndex 008	8. PDO Mapping entry	UINT32	RO	0x6030:10, 1
1A03:09	SubIndex 009	9. PDO Mapping entry	UINT32	RO	0x6030:11, 16

**Index 1C00: Sync manager type**

Index (hex)	Name	Meaning	Data type	Flags	Default
1C00:0	Sync manager type	Using the sync managers	UINT8	RO	0x04 (4 <sub>dec</sub> )
1C00:01	SubIndex 001	Sync-Manager Type Channel 1: Mailbox Write	UINT8	RO	0x01 (1 <sub>dec</sub> )
1C00:02	SubIndex 002	Sync-Manager Type Channel 2: Mailbox Read	UINT8	RO	0x02 (2 <sub>dec</sub> )
1C00:03	SubIndex 003	Sync-Manager Type Channel 3: Process Data Write (Outputs)	UINT8	RO	0x03 (3 <sub>dec</sub> )
1C00:04	SubIndex 004	Sync-Manager Type Channel 4: Process Data Read (Inputs)	UINT8	RO	0x04 (4 <sub>dec</sub> )

**Index 1C12: RxPDO assign**

Index (hex)	Name	Meaning	Data type	Flags	Default
1C12:0	RxPDO assign	PDO Assign Outputs	UINT8	RW	0x00 (0 <sub>dec</sub> )

**Index 1C13: TxPDO assign**

Index (hex)	Name	Meaning	Data type	Flags	Default
1C13:0	TxPDO assign	PDO Assign Inputs	UINT8	RW	0x04 (4 <sub>dec</sub> )
1C13:01	Subindex 001	1. allocated TxPDO (contains the index of the associated TxPDO mapping object)	UINT16	RW	0x1A00 (6656 <sub>dec</sub> )
1C13:02	Subindex 002	2. allocated TxPDO (contains the index of the associated TxPDO mapping object)	UINT16	RW	0x1A01 (6657 <sub>dec</sub> )
1C13:03	Subindex 003	3. allocated TxPDO (contains the index of the associated TxPDO mapping object)	UINT16	RW	0x1A02 (6658 <sub>dec</sub> )
1C13:04	Subindex 004	4. allocated TxPDO (contains the index of the associated TxPDO mapping object)	UINT16	RW	0x1A03 (6659 <sub>dec</sub> )

**Index 1C33: SM input parameter**

Index (hex)	Name	Meaning	Data type	Flags	Default
1C33:0	SM input parameter	Maximum subindex	UINT8	RO	0x20 (32 <sub>dec</sub> )
1C33:01	Sync mode		UINT16	RW	0x0000 (0 <sub>dec</sub> )
1C33:02	Cycle time		UINT32	RW	0x000F4240 (1000000 <sub>dec</sub> )
1C33:03	Shift time		UINT32	RO	0x00000000 (0 <sub>dec</sub> )
1C33:04	Sync modes supported		UINT16	RO	0xC007 (49159 <sub>dec</sub> )
1C33:05	Minimum cycle time		UINT32	RO	0x00002710 (10000 <sub>dec</sub> )
1C33:06	Calc and copy time		UINT32	RO	0x00000000 (0 <sub>dec</sub> )
1C33:07	Minimum delay time		UINT32	RO	0x00000000 (0 <sub>dec</sub> )
1C33:08	Command		UINT16	RW	0x0000 (0 <sub>dec</sub> )
1C33:09	Maximum Delay time		UINT32	RO	0x00000000 (0 <sub>dec</sub> )
1C33:0B	SM event missed counter		UINT16	RO	0x0000 (0 <sub>dec</sub> )
1C33:0C	Cycle exceeded counter		UINT16	RO	0x0000 (0 <sub>dec</sub> )
1C33:0D	Shift too short counter		UINT16	RO	0x0000 (0 <sub>dec</sub> )
1C33:20	Sync error		BOOLEAN	RO	0x00 (0 <sub>dec</sub> )

## 7.4.4 Profile-specific objects (0x6000-0xFFFF)

The profile-specific objects have the same meaning for all EtherCAT slaves that support the profile 5001.

### Index 6000: RTD Inputs Ch.1

Index (hex)	Name	Meaning	Data type	Flags	Default
6000:0	RTD Inputs Ch.1	Maximum subindex	UINT8	RO	0x11 (17 <sub>dec</sub> )
6000:01	Underrange	Is set if the value falls below the operating range of the sensor or the process record contains the lowest possible value.	BOOLEAN	RO	0x00 (0 <sub>dec</sub> )
6000:02	Overrange	Is set if the value exceeds the operating range of the sensor or the process record contains the highest possible value.	BOOLEAN	RO	0x00 (0 <sub>dec</sub> )
6000:03	Limit 1	Only when limit check is active	BIT2	RO	0x00 (0 <sub>dec</sub> )
		1 Value below set limit			
		2 Set limit exceeded			
		3 Set limit reached			
6000:05	Limit 2	Only when limit check is active	BIT2	RO	0x00 (0 <sub>dec</sub> )
		1 Value below set limit			
		2 Set limit exceeded			
		3 Set limit reached			
6000:07	Error	The error bit is set if the process data is invalid (wire breakage, overrange, underrange).	BOOLEAN	RO	0x00 (0 <sub>dec</sub> )
6000:0E	Sync error	Only in DC: bit is set if the slave is not able to operate synchronous with master, because it cannot keep up with the cycle time.	BOOLEAN	RO	0x00 (0 <sub>dec</sub> )
6000:0F	TxPDO State	Validity of the data of the associated TxPDO	BOOLEAN	RO	0x00 (0 <sub>dec</sub> )
		0 valid			
		1 invalid			
6000:10	TxPDO Toggle	TxPDO toggle is toggled by the slave when the data of the associated TxPDO is updated.	BOOLEAN	RO	0x00 (0 <sub>dec</sub> )
6000:11	Value	Analog input date	INT16	RO	0x0000 (0 <sub>dec</sub> )

### Index 6010: RTD Inputs Ch.2

Index (hex)	Name	Meaning	Data type	Flags	Default
6010:0	RTD Inputs Ch.2	Maximum subindex	UINT8	RO	0x11 (17 <sub>dec</sub> )
6010:01	Underrange	Is set if the value falls below the operating range of the sensor or the process record contains the lowest possible value.	BOOLEAN	RO	0x00 (0 <sub>dec</sub> )
6010:02	Overrange	Is set if the value exceeds the operating range of the sensor or the process record contains the highest possible value.	BOOLEAN	RO	0x00 (0 <sub>dec</sub> )
6010:03	Limit 1	Only when limit check is active	BIT2	RO	0x00 (0 <sub>dec</sub> )
		1 Value below set limit			
		2 Set limit exceeded			
		3 Set limit reached			
6010:05	Limit 2	Only when limit check is active	BIT2	RO	0x00 (0 <sub>dec</sub> )
		1 Value below set limit			
		2 Set limit exceeded			
		3 Set limit reached			
6010:07	Error	The error bit is set if the process data is invalid (wire breakage, overrange, underrange).	BOOLEAN	RO	0x00 (0 <sub>dec</sub> )
6010:0E	Sync error	Only in DC: bit is set if the slave is not able to operate synchronous with master, because it cannot keep up with the cycle time.	BOOLEAN	RO	0x00 (0 <sub>dec</sub> )
6010:0F	TxPDO State	Validity of the data of the associated TxPDO	BOOLEAN	RO	0x00 (0 <sub>dec</sub> )
		0 valid			
		1 invalid			
6010:10	TxPDO Toggle	TxPDO toggle is toggled by the slave when the data of the associated TxPDO is updated.	BOOLEAN	RO	0x00 (0 <sub>dec</sub> )
6010:11	Value	Analog input date	INT16	RO	0x0000 (0 <sub>dec</sub> )

## Index 6020: RTD Inputs Ch.3

Index (hex)	Name	Meaning	Data type	Flags	Default
6020:0	RTD Inputs Ch.3	Maximum subindex	UINT8	RO	0x11 (17 <sub>dec</sub> )
6020:01	Underrange	Is set if the value falls below the operating range of the sensor or the process record contains the lowest possible value.	BOOLEAN	RO	0x00 (0 <sub>dec</sub> )
6020:02	Overrange	Is set if the value exceeds the operating range of the sensor or the process record contains the highest possible value.	BOOLEAN	RO	0x00 (0 <sub>dec</sub> )
6020:03	Limit 1	Only when limit check is active	BIT2	RO	0x00 (0 <sub>dec</sub> )
		1 Value below set limit			
		2 Set limit exceeded			
		3 Set limit reached			
6020:05	Limit 2	Only when limit check is active	BIT2	RO	0x00 (0 <sub>dec</sub> )
		1 Value below set limit			
		2 Set limit exceeded			
		3 Set limit reached			
6020:07	Error	The error bit is set if the process data is invalid (cable break, overrange, underrange)	BOOLEAN	RO	0x00 (0 <sub>dec</sub> )
6020:0E	Sync error	Only in DC: bit is set if the slave is not able to operate synchronous with master, because it cannot keep up with the cycle time.	BOOLEAN	RO	0x00 (0 <sub>dec</sub> )
6020:0F	TxPDO State	Validity of the data of the associated TxPDO	BOOLEAN	RO	0x00 (0 <sub>dec</sub> )
		0 valid			
		1 invalid			
6020:10	TxPDO Toggle	TxPDO toggle is toggled by the slave when the data of the associated TxPDO is updated.	BOOLEAN	RO	0x00 (0 <sub>dec</sub> )
6020:11	Value	Analog input date	INT16	RO	0x0000 (0 <sub>dec</sub> )

## Index 6030: RTD Inputs Ch.4

Index (hex)	Name	Meaning	Data type	Flags	Default
6030:0	RTD Inputs Ch.4	Maximum subindex	UINT8	RO	0x11 (17 <sub>dec</sub> )
6030:01	Underrange	Is set if the value falls below the operating range of the sensor or the process record contains the lowest possible value.	BOOLEAN	RO	0x00 (0 <sub>dec</sub> )
6030:02	Overrange	Is set if the value exceeds the operating range of the sensor or the process record contains the highest possible value.	BOOLEAN	RO	0x00 (0 <sub>dec</sub> )
6030:03	Limit 1	Only when limit check is active	BIT2	RO	0x00 (0 <sub>dec</sub> )
		1 Value below set limit			
		2 Set limit exceeded			
		3 Set limit reached			
6030:05	Limit 2	Only when limit check is active	BIT2	RO	0x00 (0 <sub>dec</sub> )
		1 Value below set limit			
		2 Set limit exceeded			
		3 Set limit reached			
6030:07	Error	The error bit is set if the process data is invalid (wire breakage, overrange, underrange).	BOOLEAN	RO	0x00 (0 <sub>dec</sub> )
6030:0E	Sync error	Only in DC: bit is set if the slave is not able to operate synchronous with master, because it cannot keep up with the cycle time.	BOOLEAN	RO	0x00 (0 <sub>dec</sub> )
6030:0F	TxPDO State	Validity of the data of the associated TxPDO	BOOLEAN	RO	0x00 (0 <sub>dec</sub> )
		0 valid			
		1 invalid			
6030:10	TxPDO Toggle	TxPDO toggle is toggled by the slave when the data of the associated TxPDO is updated.	BOOLEAN	RO	0x00 (0 <sub>dec</sub> )
6030:11	Value	Analog input date	INT16	RO	0x0000 (0 <sub>dec</sub> )

**Index 800E: RTD Internal data Ch.1**

Index (hex)	Name	Meaning	Data type	Flags	Default
800E:0	RTD Internal data Ch.1	Maximum subindex	UINT8	RO	0x04 (4 <sub>dec</sub> )
800E:01	ADC raw value 1	Raw value of the analog/digital converter	INT32	RO	0x00000000 (0 <sub>dec</sub> )
800E:02	Resistor 1	Resistance value of the first measurement	UINT16	RO	0x0000 (0 <sub>dec</sub> )
800E:03	ADC raw value 2	Raw value of the analog/digital converter	INT32	RO	0x00000000 (0 <sub>dec</sub> )
800E:04	Resistor 2	Resistance value of the second measurement	UINT16	RO	0x0000 (0 <sub>dec</sub> )

**Index 800F: RTD Vendor data Ch.1**

Index (hex)	Name	Meaning	Data type	Flags	Default
800F:0	RTD Vendor data Ch.1	Maximum subindex	UINT8	RO	0x07 (7 <sub>dec</sub> )
800F:01	Calibration offset 3-wire	Calibration for 3-wire measurement: Offset	INT16	RW	0x0000 (0 <sub>dec</sub> )
800F:02	Calibration gain 3-wire	Calibration for 3-wire measurement: Gain	UINT16	RW	0x4000 (16384 <sub>dec</sub> )
800F:03	Calibration offset 2-wire	Calibration for 2-wire measurement: Offset	INT16	RW	0x0000 (0 <sub>dec</sub> )
800F:04	Calibration gain 2-wire	Calibration for 2-wire measurement: Gain	UINT16	RW	0x4000 (16384 <sub>dec</sub> )
800F:05	Calibration offset 4-wire	Calibration for 4-wire measurement: Offset	INT16	RW	0x0000 (0 <sub>dec</sub> )
800F:06	Calibration gain 4-wire	Calibration for 4-wire measurement: Gain	UINT16	RW	0x4000 (16384 <sub>dec</sub> )
800F:07	PGA Gain Correction	Gain correction for Pt1000 measurement	INT16	RW	0x0000 (0 <sub>dec</sub> )

**Index 801E: RTD Internal data Ch.2**

Index (hex)	Name	Meaning	Data type	Flags	Default
801E:0	RTD Internal data Ch.2	Maximum subindex	UINT8	RO	0x04 (4 <sub>dec</sub> )
801E:01	ADC raw value 1	Raw value of the analog/digital converter	INT32	RO	0x00000000 (0 <sub>dec</sub> )
801E:02	Resistor 1	Resistance value of the first measurement	UINT16	RO	0x0000 (0 <sub>dec</sub> )
801E:03	ADC raw value 2	Raw value of the analog/digital converter	INT32	RO	0x00000000 (0 <sub>dec</sub> )
801E:04	Resistor 2	Resistance value of the second measurement	UINT16	RO	0x0000 (0 <sub>dec</sub> )

**Index 801F: RTD Vendor data Ch.2**

Index (hex)	Name	Meaning	Data type	Flags	Default
801F:0	RTD Vendor data Ch.2	Maximum subindex	UINT8	RO	0x07 (7 <sub>dec</sub> )
801F:01	Calibration offset 3-wire	Calibration for 3-wire measurement: Offset	INT16	RW	0x0000 (0 <sub>dec</sub> )
801F:02	Calibration gain 3-wire	Calibration for 3-wire measurement: Gain	UINT16	RW	0x4000 (16384 <sub>dec</sub> )
801F:03	Calibration offset 2-wire	Calibration for 2-wire measurement: Offset	INT16	RW	0x0000 (0 <sub>dec</sub> )
801F:04	Calibration gain 2-wire	Calibration for 2-wire measurement: Gain	UINT16	RW	0x4000 (16384 <sub>dec</sub> )
801F:05	Calibration offset 4-wire	Calibration for 4-wire measurement: Offset	INT16	RW	0x0000 (0 <sub>dec</sub> )
801F:06	Calibration gain 4-wire	Calibration for 4-wire measurement: Gain	UINT16	RW	0x4000 (16384 <sub>dec</sub> )
801F:07	PGA Gain Correction	Gain correction for Pt1000 measurement	INT16	RW	0x0000 (0 <sub>dec</sub> )



**Index 802E: RTD Internal data Ch.3**

Index (hex)	Name	Meaning	Data type	Flags	Default
802E:0	RTD Internal data Ch.3	Maximum subindex	UINT8	RO	0x04 (4 <sub>dec</sub> )
802E:01	ADC raw value 1	Raw value of the analog/digital converter	INT32	RO	0x00000000 (0 <sub>dec</sub> )
802E:02	Resistor 1	Resistance value of the first measurement	UINT16	RO	0x0000 (0 <sub>dec</sub> )
802E:03	ADC raw value 2	Raw value of the analog/digital converter	INT32	RO	0x00000000 (0 <sub>dec</sub> )
802E:04	Resistor 2	Resistance value of the second measurement	UINT16	RO	0x0000 (0 <sub>dec</sub> )

**Index 802F: RTD Vendor data Ch.3**

Index (hex)	Name	Meaning	Data type	Flags	Default
802F:0	RTD Vendor data Ch.3	Maximum subindex	UINT8	RO	0x07 (7 <sub>dec</sub> )
802F:01	Calibration offset 3-wire	Calibration for 3-wire measurement: Offset	INT16	RW	0x0000 (0 <sub>dec</sub> )
802F:02	Calibration gain 3-wire	Calibration for 3-wire measurement: Gain	UINT16	RW	0x4000 (16384 <sub>dec</sub> )
802F:03	Calibration offset 2-wire	Calibration for 2-wire measurement: Offset	INT16	RW	0x0000 (0 <sub>dec</sub> )
802F:04	Calibration gain 2-wire	Calibration for 2-wire measurement: Gain	UINT16	RW	0x4000 (16384 <sub>dec</sub> )
802F:05	Calibration offset 4-wire	Calibration for 4-wire measurement: Offset	INT16	RW	0x0000 (0 <sub>dec</sub> )
802F:06	Calibration gain 4-wire	Calibration for 4-wire measurement: Gain	UINT16	RW	0x4000 (16384 <sub>dec</sub> )
802F:07	PGA Gain Correction	Gain correction for Pt1000 measurement	INT16	RW	0x0000 (0 <sub>dec</sub> )

**Index 803E: RTD Internal data Ch.4**

Index (hex)	Name	Meaning	Data type	Flags	Default
803E:0	RTD Internal data Ch.4	Maximum subindex	UINT8	RO	0x04 (4 <sub>dec</sub> )
803E:01	ADC raw value 1	Raw value of the analog/digital converter	INT32	RO	0x00000000 (0 <sub>dec</sub> )
803E:02	Resistor 1	Resistance value of the first measurement	UINT16	RO	0x0000 (0 <sub>dec</sub> )
803E:03	ADC raw value 2	Raw value of the analog/digital converter	INT32	RO	0x00000000 (0 <sub>dec</sub> )
803E:04	Resistor 2	Resistance value of the second measurement	UINT16	RO	0x0000 (0 <sub>dec</sub> )

**Index 803F: RTD Vendor data Ch.4**

Index (hex)	Name	Meaning	Data type	Flags	Default
803F:0	RTD Vendor data Ch.4		UINT8	RO	0x07 (7 <sub>dec</sub> )
803F:01	Calibration offset 3-wire	Calibration for 3-wire measurement: Offset	INT16	RW	0x0000 (0 <sub>dec</sub> )
803F:02	Calibration gain 3-wire	Calibration for 3-wire measurement: Gain	UINT16	RW	0x4000 (16384 <sub>dec</sub> )
803F:03	Calibration offset 2-wire	Calibration for 2-wire measurement: Offset	INT16	RW	0x0000 (0 <sub>dec</sub> )
803F:04	Calibration gain 2-wire	Calibration for 2-wire measurement: Gain	UINT16	RW	0x4000 (16384 <sub>dec</sub> )
803F:05	Calibration offset 4-wire	Calibration for 4-wire measurement: Offset	INT16	RW	0x0000 (0 <sub>dec</sub> )
803F:06	Calibration gain 4-wire	Calibration for 4-wire measurement: Gain	UINT16	RW	0x4000 (16384 <sub>dec</sub> )
803F:07	PGA Gain Correction	Gain correction for Pt1000 measurement	INT16	RW	0x0000 (0 <sub>dec</sub> )



**Index F000: Modular device profile**

Index (hex)	Name	Meaning	Data type	Flags	Default
F000:0	Modular device profile	Maximum subindex	UINT8	RO	0x02 (2 <sub>dec</sub> )
F000:01	Module index distance	Index spacing for the objects of the individual channels	UINT16	RO	0x0010 (16 <sub>dec</sub> )
F000:02	Maximum number of modules	Number of channels	UINT16	RO	0x0004 (4 <sub>dec</sub> )

**Index F008: Code word**

Index (hex)	Name	Meaning	Data type	Flags	Default
F008:0	Code word	reserved	UINT32	RW	0x00000000 (0 <sub>dec</sub> )

**Index F010: Module list**

Index (hex)	Name	Meaning	Data type	Flags	Default
F010:0	Module list	Maximum subindex	UINT8	RW	0x04 (4 <sub>dec</sub> )
F010:01	SubIndex 001		UINT32	RW	0x00000140 (320 <sub>dec</sub> )
F010:02	SubIndex 002		UINT32	RW	0x00000140 (320 <sub>dec</sub> )
F010:03	SubIndex 003		UINT32	RW	0x00000140 (320 <sub>dec</sub> )
F010:04	SubIndex 004		UINT32	RW	0x00000140 (320 <sub>dec</sub> )

**Index F080: Channel Enable**

Index (hex)	Name	Meaning	Data type	Flags	Default	
F080:0	Channel Enable	Maximum subindex	UINT8	RO	0x04 (4 <sub>dec</sub> )	
F080:01	SubIndex 001	0 Channel 1 disabled	(from hardware version 01 deactivated channels are not measured, and the green LED R for these channels goes out)	BOOLEAN	RW	0x01 (1 <sub>dec</sub> )
		1 Channel 1 enabled				
F080:02	SubIndex 002	0 Channel 2 disabled		BOOLEAN	RW	0x01 (1 <sub>dec</sub> )
		1 Channel 2 enabled				
F080:03	SubIndex 003	0 Channel 3 disabled		BOOLEAN	RW	0x01 (1 <sub>dec</sub> )
		1 Channel 3 enabled				
F080:04	SubIndex 004	0 Channel 4 disabled		BOOLEAN	RW	0x01 (1 <sub>dec</sub> )
		1 Channel 5 enabled				

## 7.5 EP3314 - Settings

### 7.5.1 Cold junction compensation

You can set the cold junction compensation type for each channel individually in the parameters  $80n0:0C_{hex}$  "Coldjunction Compensation".

- Channel 1: Parameter  $8000:0C_{hex}$
- Channel 2: Parameter  $8010:0C_{hex}$
- Channel 3: Parameter  $8020:0C_{hex}$
- Channel 4: Parameter  $8030:0C_{hex}$

The possible values for these parameters are described below.

#### Value 0 "intern"

In the factory setting, all parameters  $80n0:0C_{hex}$  are set to "intern". With this setting, the cold junction temperature is measured individually at each channel.

A Pt1000 measuring resistor must also be connected to each channel to which a thermocouple is connected. See [Connection example 1 \[▶ 38\]](#).

#### Value 1 "none"

No cold junction compensation is performed. This setting is useful if the cold junction is in an ice bath at 0 °C.

#### Value 2 "external process data (1/100°C)"

This setting is intended for a situation where the cold junction temperature is measured with a separate measuring device, for example.

Enable the process data 0x1600 to 0x1603 in the Process Data tab. You can transfer the externally measured cold junction temperatures to the box via the process data objects "TC Outputs Channel n".

#### Value 3 "by coldjunction temp. of channel 1"

With this setting, the cold junction temperature of channel 1 is used for cold junction compensation of the other channels. This saves the costs of a separate Pt1000 resistor for each channel. See [Connection example 2 \[▶ 39\]](#).

However, large measuring errors can occur with this setting. The setting is only recommended if the temperature difference between the cold junction of a channel and the cold junction of channel 1 is constant.

Example: Enabling the cold junction of channel 1 for channel 2

1. Make sure that the temperature difference between the cold junctions of the channels is as constant as possible.
2. Set the parameter  $8010:0C_{hex}$  "Coldjunction Compensation" to the value "by coldjunction temp. of channel 1".
3. Determine the constant temperature difference between the cold junctions of channel 1 and channel 2:  
 $T_{delta} = T_{V1} - T_{V2}$   
 If the cold junction of channel 1 is warmer than that of channel 2, the value  $T_{delta}$  is positive.
4. Enter the temperature offset in parameter  $8010:1C_{hex}$  "Coldjunction temperature offset from channel 1". The unit is 1/100 °C.  
 Example: for a temperature difference of 0.5 °C enter the value 50 here.

The procedure is the same for channels 3 and 4. The corresponding parameters are:

- Channel 3
  - $8020:0C_{hex}$  „Coldjunction Compensation“

- 8020:1C<sub>hex</sub> „Coldjunction temperature offset from channel 1“
- Channel 4
  - 8030:0C<sub>hex</sub> „Coldjunction Compensation“
  - 8030:1C<sub>hex</sub> „Coldjunction temperature offset from channel 1“

## 7.5.2 Presentation, index 0x80n0:02

In the delivery state, the measured value is output in increments of 1/10° C in two's complement format (signed integer).

Index 0x80n0:02 offers the possibility to change the method of representation of the measured value.

Measured value	Output (hexadecimal)	Output (signed integer, decimal)
-200.0 °C	0nF830	-2000
-100.0 °C	0nFC18	-1000
-0.1 °C	0nFFFF	-1
0.0 °C	0n0000	0
0.1 °C	0n0001	1
100.0 °C	0n03E8	1000
200.0 °C	0n07D0	2000
500.0 °C	0x1388	5000
850.0 °C	0x2134	8500
1000.0 °C	0x2170	10000

Table 2: Output of measured value and process data

- **Signed Integer:**

The measured value is presented in two's complement format.

Maximum presentation range for 16 bit = -32768 .. +32767

- Example:

- 1000 0000 0000 0000<sub>bin</sub> = 0x8000<sub>hex</sub> = - 32768<sub>dec</sub>
- 1111 1111 1111 1110<sub>bin</sub> = 0nFFFE<sub>hex</sub> = - 2<sub>dec</sub>
- 1111 1111 1111 1111<sub>bin</sub> = 0nFFFF<sub>hex</sub> = - 1<sub>dec</sub>
- 0000 0000 0000 0001<sub>bin</sub> = 0n0001<sub>hex</sub> = +1<sub>dec</sub>
- 0000 0000 0000 0010<sub>bin</sub> = 0n0002<sub>hex</sub> = +2<sub>dec</sub>
- 0111 1111 1111 1111<sub>bin</sub> = 0x7FFF<sub>hex</sub> = +32767<sub>dec</sub>

- **Absolute value with MSB as sign:**

The measured value is output in magnitude-sign format.

Maximum presentation range for 16 bit = -32767 .. +32767

- Example:

- 1111 1111 1111 1111<sub>bin</sub> = 0nFFFF<sub>hex</sub> = - 32767<sub>dec</sub>
- 1000 0000 0000 0010<sub>bin</sub> = 0x8002<sub>hex</sub> = - 2<sub>dec</sub>
- 1000 0000 0000 0001<sub>bin</sub> = 0x8001<sub>hex</sub> = - 1<sub>dec</sub>
- 0000 0000 0000 0001<sub>bin</sub> = 0n0001<sub>hex</sub> = +1<sub>dec</sub>
- 0000 0000 0000 0010<sub>bin</sub> = 0n0002<sub>hex</sub> = +2<sub>dec</sub>
- 0111 1111 1111 1111<sub>bin</sub> = 0x7FFF<sub>hex</sub> = +32767<sub>dec</sub>

- **High resolution (1/100 C°):**

The measured value is output in 1/100 °C steps.

### 7.5.3 Siemens bits, index 0x80n0:05

If the bit in index 0x80n0:05 is set, status displays are shown for the lowest 3 bits. In the error case "overrange" or "underrange", bit 0 is set.

### 7.5.4 Underrange, Overage

#### Undershoot and overshoot of the measuring range (underrange, overrange), index 0x60n0:02, 0x60n0:03

- $U_k > U_{k_{max}}$ : Index 0x60n0:02 and index 0x60n0:07 (overrange and error bit) are set. The linearization of the characteristic curve is continued with the coefficients of the overrange limit up to the limit stop of the A/D converter or to the maximum value of 0x7FFF.
- $U_k < U_{k_{min}}$ : Index 0x60n0:01 and index 0x60n0:07 (underrange and error bit) are set. The linearization of the characteristic curve is continued with the coefficients of the underrange limit up to the limit stop of the A/D converter or to the minimum value of 0x8000.

For overrange or underrange the red error LED is switched on.

### 7.5.5 Filter

Each analog input has a digital filter. The filter is a notch filter.

The filter is always active; it cannot be disabled. None of the "Enable Filter" parameters have any effect: 0x8000:06, 0x8010:06, 0x8020:06, 0x8030:06.

#### Configuring the filter

You can set the filter frequency in the parameter 0x8000:15 "Filter Settings". This parameter affects all channels. The "Filter Settings" parameters of the other channels have no effect: 0x8010:15, 0x8020:15, 0x8030:15.

#### Influence on the conversion time

The higher the filter frequency, the shorter the conversion time.

### 7.5.6 Limit 1 and Limit 2

#### Limit 1 and limit 2, index 0x80n0:13, index 0x80n0:14

A temperature range can be set that is limited by the values in the indices 0x80n0:13 and 0x80n0:14. If the limit values are overshoot, the bits in indices 0x80n0:07 and 0x80n0:08 are set.

The temperature value is entered with a resolution of 0.1 °C.

#### Example:

Limit 1 = 30 °C  
Value index 0x80n0:13 = 300

## 7.5.7 Calibration

### Vendor calibration, index 0x80n0:0B

The vendor calibration is enabled via index 0x80n0:0B. Parameterization takes place via the indices

- 0x80nF:01  
Thermocouple offset (vendor calibration)
- 0x80nF:02  
Thermocouple gain (vendor calibration)
- 0x80nF:03  
Reference point offset [Pt1000] (vendor calibration)
- 0x80nF:04  
Reference point gain [Pt1000] (vendor calibration)

### **i** Vendor and user calibration

User calibration (index 0x80n0:0A) should only be performed instead of the vendor calibration (index 0x80n0:0B), but this is generally only necessary in exceptional cases.

### User calibration , index 0x80n0:0A

User calibration is enabled via index 0x80n0:0A. Parameterization takes place via the indices

- 0x80n0:17  
Thermocouple offset (index 0x80nF:01, user calibration)
- 0x80n0:18  
Thermocouple gain (index 0x80nF:02, user calibration)

### User scaling, index 0x80n0:01

The user scaling is enabled via index 0x80n0:01. Parameterization takes place via the indices

- 0x80n0:11  
User scaling offset

The offset describes a vertical shift of the characteristic curve by a linear amount.

At a resolution of  $0.1^\circ$ , 1 digit<sub>(dec)</sub> corresponds to an increase in measured value by  $0.1^\circ$

At a resolution of  $0.01^\circ$ , 1 digit<sub>(dec)</sub> corresponds to an increase in measured value by 0.01

- 0x80n0:12  
User scaling gain

•

The default value of 65536<sub>(dec)</sub> corresponds to gain = 1.

The new gain value for 2-point user calibration after offset calibration is determined as follows:

$$\text{Gain\_new} = \text{reference temperature} / \text{measured value} \times 65536_{(\text{dec})}$$

### Calculation of process data

*The concept "calibration", which has historical roots at Beckhoff, is used here even if it has nothing to do with the deviation statements of a calibration certificate. Actually, this is a description of the vendor or customer calibration data/adjustment data used by the device during operation in order to maintain the assured measuring accuracy.*

The box constantly records measured values and saves the raw values from its A/D converter in the ADC raw value objects 0x80nE:01, 0x80nE:02. After each recording of the analog signal, the correction calculation takes place with the vendor and user calibration data as well as the user scaling, if these are activated (see following picture).

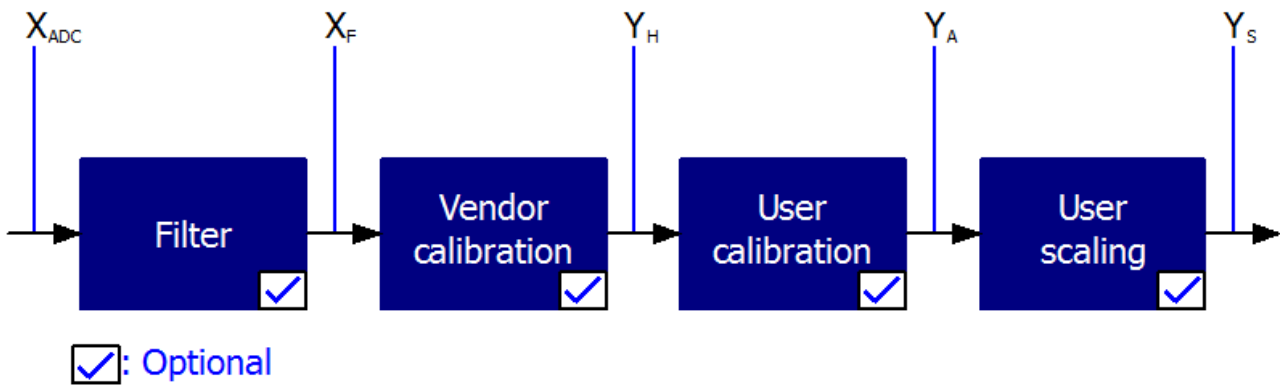

Fig. 23: Calculation of process data

Calculation	Designation
$X_{ADC}$	Output of the A/D converter
$X_F$	Output value after the filter
$Y_H = (X_{ADC} - B_H) \times A_H \times 2^{-14}$	Measured value after vendor calibration,
$Y_A = (Y_H - B_A) \times A_A \times 2^{-14}$	Measured value after vendor and user calibration
$Y_S = Y_A \times A_S \times 2^{-16} + B_S$	Measured value following user scaling

Table 1: Legend

Name	Designation	Index
$X_{ADC}$	Output value of the A/D converter	0x80nE:01
$X_F$	Output value after the filter	-
$B_H$	Vendor calibration offset (not changeable)	0x80nF:01
$A_H$	Vendor calibration gain (not changeable)	0x80nF:02
$B_A$	User calibration offset (can be activated via index 0x80n0:0A)	0x80n0:17
$A_A$	User calibration gain (can be activated via index 0x80n0:0A)	0x80n0:18
$B_S$	User scaling offset (can be activated via index 0x80n0:01)	0x80n0:11
$A_S$	User scaling gain (can be activated via index 0x80n0:01)	0x80n0:12
$Y_S$	Process data for controller	-

**i Measurement result**

The accuracy of the result may be reduced if the measured value is smaller than 32767 / 4 due to one or more multiplications.

## 7.6 EP3314 - object overview

### **i** EtherCAT XML Device Description

The display matches that of the CoE objects from the EtherCAT XML Device Description. We recommend downloading the latest XML file from the download area of the Beckhoff website and installing it according to installation instructions.

Index (hex)	Name	Flags	Default value	
1000 <a href="#">[▶ 93]</a>	Device type	RO	0x014A1389 (21631881 <sub>dec</sub> )	
1008 <a href="#">[▶ 93]</a>	Device name	RO	EP3314-0002	
1009 <a href="#">[▶ 93]</a>	Hardware version	RO	00	
100A <a href="#">[▶ 93]</a>	Software version	RO	01	
1011:0 <a href="#">[▶ 87]</a>	<b>Subindex</b>	Restore default parameters	RO	0x01 (1 <sub>dec</sub> )
	1011:01	SubIndex 001	RW	0x00000000 (0 <sub>dec</sub> )
1018:0 <a href="#">[▶ 93]</a>	<b>Subindex</b>	Identity	RO	0x04 (4 <sub>dec</sub> )
	1018:01	Vendor ID	RO	0x00000002 (2 <sub>dec</sub> )
	1018:02	Product code	RO	0x0CF24052 (217202770 <sub>dec</sub> )
	1018:03	Revision	RO	0x00100002 (1048578 <sub>dec</sub> )
	1018:04	Serial number	RO	0x00000000 (0 <sub>dec</sub> )
10F0:0 <a href="#">[▶ 93]</a>	<b>Subindex</b>	Backup parameter handling	RO	0x01 (1 <sub>dec</sub> )
	10F0:01	Checksum	RO	0x00000000 (0 <sub>dec</sub> )
1600:0 <a href="#">[▶ 93]</a>	<b>Subindex</b>	TC RxPDO-Map Outputs Ch.1	RO	0x01 (1 <sub>dec</sub> )
	1600:01	SubIndex 001	RO	0x7000:11, 16
1601:0 <a href="#">[▶ 94]</a>	<b>Subindex</b>	TC RxPDO-Map Outputs Ch.2	RO	0x01 (1 <sub>dec</sub> )
	1601:01	SubIndex 001	RO	0x7010:11, 16
1602:0 <a href="#">[▶ 94]</a>	<b>Subindex</b>	TC RxPDO-Map Outputs Ch.3	RO	0x01 (1 <sub>dec</sub> )
	1602:01	SubIndex 001	RO	0x7020:11, 16
1603:0 <a href="#">[▶ 94]</a>	<b>Subindex</b>	TC RxPDO-Map Outputs Ch.4	RO	0x01 (1 <sub>dec</sub> )
	1603:01	SubIndex 001	RO	0x7030:11, 16
1A00:0 <a href="#">[▶ 94]</a>	<b>Subindex</b>	TC TxPDO-Map TCInputs Ch.1	RO	0x0A (10 <sub>dec</sub> )
	1A00:01	SubIndex 001	RO	0x6000:01, 1
	1A00:02	SubIndex 002	RO	0x6000:02, 1
	1A00:03	SubIndex 003	RO	0x6000:03, 2
	1A00:04	SubIndex 004	RO	0x6000:05, 2
	1A00:05	SubIndex 005	RO	0x6000:07, 1
	1A00:06	SubIndex 006	RO	0x0000:00, 6
	1A00:07	SubIndex 007	RO	0x6000:0E, 1
	1A00:08	SubIndex 008	RO	0x1800:07, 1
	1A00:09	SubIndex 009	RO	0x1800:09, 1
1A00:0A	SubIndex 010	RO	0x6000:11, 16	



Index (hex)		Name	Flags	Default value
1A01:0 [▶ 95]	<b>Subindex</b>	TC TxPDO-Map TCInputs Ch.2	RO	0x0A (10 <sub>dec</sub> )
	1A01:01	SubIndex 001	RO	0x6010:01, 1
	1A01:02	SubIndex 002	RO	0x6010:02, 1
	1A01:03	SubIndex 003	RO	0x6010:03, 2
	1A01:04	SubIndex 004	RO	0x6010:05, 2
	1A01:05	SubIndex 005	RO	0x6010:07, 1
	1A01:06	SubIndex 006	RO	0x0000:00, 6
	1A01:07	SubIndex 007	RO	0x6010:0E, 1
	1A01:08	SubIndex 008	RO	0x1801:07, 1
	1A01:09	SubIndex 009	RO	0x1801:09, 1
	1A01:0A	SubIndex 010	RO	0x6010:11, 16
1A02:0 [▶ 95]	<b>Subindex</b>	TC TxPDO-Map TCInputs Ch.3	RO	0x0A (10 <sub>dec</sub> )
	1A02:01	SubIndex 001	RO	0x6020:01, 1
	1A02:02	SubIndex 002	RO	0x6020:02, 1
	1A02:03	SubIndex 003	RO	0x6020:03, 2
	1A02:04	SubIndex 004	RO	0x6020:05, 2
	1A02:05	SubIndex 005	RO	0x6020:07, 1
	1A02:06	SubIndex 006	RO	0x0000:00, 6
	1A02:07	SubIndex 007	RO	0x6020:0E, 1
	1A02:08	SubIndex 008	RO	0x1802:07, 1
	1A02:09	SubIndex 009	RO	0x1802:09, 1
	1A02:0A	SubIndex 010	RO	0x6020:11, 16
1A03:0 [▶ 96]	<b>Subindex</b>	TC TxPDO-Map TCInputs Ch.4	RO	0x0A (10 <sub>dec</sub> )
	1A03:01	SubIndex 001	RO	0x6030:01, 1
	1A03:02	SubIndex 002	RO	0x6030:02, 1
	1A03:03	SubIndex 003	RO	0x6030:03, 2
	1A03:04	SubIndex 004	RO	0x6030:05, 2
	1A03:05	SubIndex 005	RO	0x6030:07, 1
	1A03:06	SubIndex 006	RO	0x0000:00, 6
	1A03:07	SubIndex 007	RO	0x6030:0E, 1
	1A03:08	SubIndex 008	RO	0x1803:07, 1
	1A03:09	SubIndex 009	RO	0x1803:09, 1
	1A03:0A	SubIndex 010	RO	0x6030:11, 16
1C00:0 [▶ 96]	<b>Subindex</b>	Sync manager type	RO	0x04 (4 <sub>dec</sub> )
	1C00:01	SubIndex 001	RO	0x01 (1 <sub>dec</sub> )
	1C00:02	SubIndex 002	RO	0x02 (2 <sub>dec</sub> )
	1C00:03	SubIndex 003	RO	0x03 (3 <sub>dec</sub> )
	1C00:04	SubIndex 004	RO	0x04 (4 <sub>dec</sub> )

Index (hex)		Name	Flags	Default value
1C12:0 [▶ 96]	<b>Subindex</b>	RxPDO assign	RW	0x00 (0 <sub>dec</sub> )
	1C12:01	SubIndex 001	RW	0x0000 (0 <sub>dec</sub> )
	1C12:02	SubIndex 002	RW	0x0000 (0 <sub>dec</sub> )
	1C12:03	SubIndex 003	RW	0x0000 (0 <sub>dec</sub> )
	1C12:04	SubIndex 004	RW	0x0000 (0 <sub>dec</sub> )
1C13:0 [▶ 96]	<b>Subindex</b>	TxPDO assign	RW	0x04 (4 <sub>dec</sub> )
	1C13:01	SubIndex 001	RW	0x1A00 (6656 <sub>dec</sub> )
	1C13:02	SubIndex 002	RW	0x1A01 (6657 <sub>dec</sub> )
	1C13:03	SubIndex 003	RW	0x1A02 (6658 <sub>dec</sub> )
	1C13:04	SubIndex 004	RW	0x1A03 (6659 <sub>dec</sub> )
1C32:0 [▶ 97]	<b>Subindex</b>	SM output parameter	RO	0x20 (32 <sub>dec</sub> )
	1C32:01	Sync mode	RW	0x0000 (0 <sub>dec</sub> )
	1C32:02	Cycle time	RW	0x000F4240 (1000000 <sub>dec</sub> )
	1C32:03	Shift time	RO	0x00000000 (0 <sub>dec</sub> )
	1C32:04	Sync modes supported	RO	0xC007 (49159 <sub>dec</sub> )
	1C32:05	Minimum cycle time	RO	0x00002710 (10000 <sub>dec</sub> )
	1C32:06	Calc and copy time	RO	0x00000000 (0 <sub>dec</sub> )
	1C32:07	Minimum delay time	RO	0x00000000 (0 <sub>dec</sub> )
	1C32:08	Command	RW	0x0000 (0 <sub>dec</sub> )
	1C32:09	Maximum Delay time	RO	0x00000000 (0 <sub>dec</sub> )
	1C32:0B	SM event missed counter	RO	0x0000 (0 <sub>dec</sub> )
	1C32:0C	Cycle exceeded counter	RO	0x0000 (0 <sub>dec</sub> )
	1C32:0D	Shift too short counter	RO	0x0000 (0 <sub>dec</sub> )
	1C32:20	Sync error	RO	0x00 (0 <sub>dec</sub> )
1C33:0 [▶ 98]	<b>Subindex</b>	SM input parameter	RO	0x20 (32 <sub>dec</sub> )
	1C33:01	Sync mode	RW	0x0000 (0 <sub>dec</sub> )
	1C33:02	Cycle time	RW	0x000F4240 (1000000 <sub>dec</sub> )
	1C33:03	Shift time	RO	0x00000000 (0 <sub>dec</sub> )
	1C33:04	Sync modes supported	RO	0xC007 (49159 <sub>dec</sub> )
	1C33:05	Minimum cycle time	RO	0x00002710 (10000 <sub>dec</sub> )
	1C33:06	Calc and copy time	RO	0x00000000 (0 <sub>dec</sub> )
	1C33:07	Minimum delay time	RO	0x00000000 (0 <sub>dec</sub> )
	1C33:08	Command	RW	0x0000 (0 <sub>dec</sub> )
	1C33:09	Maximum Delay time	RO	0x00000000 (0 <sub>dec</sub> )
	1C33:0B	SM event missed counter	RO	0x0000 (0 <sub>dec</sub> )
	1C33:0C	Cycle exceeded counter	RO	0x0000 (0 <sub>dec</sub> )
	1C33:0D	Shift too short counter	RO	0x0000 (0 <sub>dec</sub> )
	1C33:20	Sync error	RO	0x00 (0 <sub>dec</sub> )
6000:0 [▶ 99]	<b>Subindex</b>	TC Inputs Ch.1	RO	0x11 (17 <sub>dec</sub> )
	6000:01	Underrange	RO	0x00 (0 <sub>dec</sub> )
	6000:02	Overrange	RO	0x00 (0 <sub>dec</sub> )
	6000:03	Limit 1	RO	0x00 (0 <sub>dec</sub> )
	6000:05	Limit 2	RO	0x00 (0 <sub>dec</sub> )
	6000:07	Error	RO	0x00 (0 <sub>dec</sub> )
	6000:0E	Sync error	RO	0x00 (0 <sub>dec</sub> )
	6000:0F	TxPDO State	RO	0x00 (0 <sub>dec</sub> )
	6000:10	TxPDO Toggle	RO	0x00 (0 <sub>dec</sub> )
	6000:11	Value	RO	0x0000 (0 <sub>dec</sub> )

Index (hex)		Name	Flags	Default value
6010:0 [▶ 99]	<b>Subindex</b>	TC Inputs Ch.2	RO	0x11 (17 <sub>dec</sub> )
	6010:01	Underrange	RO	0x00 (0 <sub>dec</sub> )
	6010:02	Overrange	RO	0x00 (0 <sub>dec</sub> )
	6010:03	Limit 1	RO	0x00 (0 <sub>dec</sub> )
	6010:05	Limit 2	RO	0x00 (0 <sub>dec</sub> )
	6010:07	Error	RO	0x00 (0 <sub>dec</sub> )
	6010:0E	Sync error	RO	0x00 (0 <sub>dec</sub> )
	6010:0F	TxPDO State	RO	0x00 (0 <sub>dec</sub> )
	6010:10	TxPDO Toggle	RO	0x00 (0 <sub>dec</sub> )
	6010:11	Value	RO	0x0000 (0 <sub>dec</sub> )
6020:0 [▶ 100]	<b>Subindex</b>	TC Inputs Ch.3	RO	0x11 (17 <sub>dec</sub> )
	6020:01	Underrange	RO	0x00 (0 <sub>dec</sub> )
	6020:02	Overrange	RO	0x00 (0 <sub>dec</sub> )
	6020:03	Limit 1	RO	0x00 (0 <sub>dec</sub> )
	6020:05	Limit 2	RO	0x00 (0 <sub>dec</sub> )
	6020:07	Error	RO	0x00 (0 <sub>dec</sub> )
	6020:0E	Sync error	RO	0x00 (0 <sub>dec</sub> )
	6020:0F	TxPDO State	RO	0x00 (0 <sub>dec</sub> )
	6020:10	TxPDO Toggle	RO	0x00 (0 <sub>dec</sub> )
	6020:11	Value	RO	0x0000 (0 <sub>dec</sub> )
6030:0 [▶ 100]	<b>Subindex</b>	TC Inputs Ch.4	RO	0x11 (17 <sub>dec</sub> )
	6030:01	Underrange	RO	0x00 (0 <sub>dec</sub> )
	6030:02	Overrange	RO	0x00 (0 <sub>dec</sub> )
	6030:03	Limit 1	RO	0x00 (0 <sub>dec</sub> )
	6030:05	Limit 2	RO	0x00 (0 <sub>dec</sub> )
	6030:07	Error	RO	0x00 (0 <sub>dec</sub> )
	6030:0E	Sync error	RO	0x00 (0 <sub>dec</sub> )
	6030:0F	TxPDO State	RO	0x00 (0 <sub>dec</sub> )
	6030:10	TxPDO Toggle	RO	0x00 (0 <sub>dec</sub> )
	6030:11	Value	RO	0x0000 (0 <sub>dec</sub> )
7000:0 [▶ 101]	<b>Subindex</b>	TC Outputs Ch.1	RO	0x11 (17 <sub>dec</sub> )
	7000:11	CJCompensation	RO	0x0000 (0 <sub>dec</sub> )
7010:0 [▶ 101]	<b>Subindex</b>	TC Outputs Ch.2	RO	0x11 (17 <sub>dec</sub> )
	7010:11	CJCompensation	RO	0x0000 (0 <sub>dec</sub> )
7020:0 [▶ 101]	<b>Subindex</b>	TC Outputs Ch.3	RO	0x11 (17 <sub>dec</sub> )
	7020:11	CJCompensation	RO	0x0000 (0 <sub>dec</sub> )
7030:0 [▶ 101]	<b>Subindex</b>	TC Outputs Ch.4	RO	0x11 (17 <sub>dec</sub> )
	7030:11	CJCompensation	RO	0x0000 (0 <sub>dec</sub> )

Index (hex)		Name	Flags	Default value
8000:0 [▶ 88]	<b>Subindex</b>	TC Settings Ch.1	RW	0x1B (27 <sub>dec</sub> )
	8000:01	Enable user scale	RW	0x00 (0 <sub>dec</sub> )
	8000:02	Presentation	RW	0x00 (0 <sub>dec</sub> )
	8000:05	Siemens bits	RW	0x00 (0 <sub>dec</sub> )
	8000:06	Enable filter	RW	0x00 (0 <sub>dec</sub> )
	8000:07	Enable limit 1	RW	0x00 (0 <sub>dec</sub> )
	8000:08	Enable limit 2	RW	0x00 (0 <sub>dec</sub> )
	8000:0A	Enable user calibration	RW	0x00 (0 <sub>dec</sub> )
	8000:0B	Enable vendor calibration	RW	0x01 (1 <sub>dec</sub> )
	8000:0C	Coldjunction compensation	RW	0x00 (0 <sub>dec</sub> )
	8000:0E	Swap limit bits	RW	0x00 (0 <sub>dec</sub> )
	8000:11	User scale offset	RW	0x0000 (0 <sub>dec</sub> )
	8000:12	User scale gain	RW	0x00010000 (65536 <sub>dec</sub> )
	8000:13	Limit 1	RW	0x0000 (0 <sub>dec</sub> )
	8000:14	Limit 2	RW	0x0000 (0 <sub>dec</sub> )
	8000:15	Filter settings	RW	0x0000 (0 <sub>dec</sub> )
	8000:16	Calibration interval	RW	0x0000 (0 <sub>dec</sub> )
	8000:17	User calibration offset	RW	0x0000 (0 <sub>dec</sub> )
	8000:18	User calibration gain	RW	0x4000 (16384 <sub>dec</sub> )
	8000:19	Sensor type	RW	0x0000 (0 <sub>dec</sub> )
	8000:1B	Wire calibration 1/32 Ohm	RW	0x0000 (0 <sub>dec</sub> )
800E:0 [▶ 101]	<b>Subindex</b>	TC Internal data Ch.1	RO	0x05 (5 <sub>dec</sub> )
	800E:01	ADC raw value TC	RO	0x00000000 (0 <sub>dec</sub> )
	800E:02	ADC raw value PT1000	RO	0x00000000 (0 <sub>dec</sub> )
	800E:03	CJ temperature	RO	0x0000 (0 <sub>dec</sub> )
	800E:04	CJ voltage	RO	0x0000 (0 <sub>dec</sub> )
	800E:05	CJ resistor	RO	0x0000 (0 <sub>dec</sub> )
800F:0 [▶ 101]	<b>Subindex</b>	TC Vendor data Ch.1	RW	0x04 (4 <sub>dec</sub> )
	800F:01	Calibration offset TC	RW	0x0000 (0 <sub>dec</sub> )
	800F:02	Calibration gain TC	RW	0x4000 (16384 <sub>dec</sub> )
	800F:03	Calibration offset CJ	RW	0x0000 (0 <sub>dec</sub> )
	800F:04	Calibration gain CJ	RW	0x4000 (16384 <sub>dec</sub> )
8010:0 [▶ 89]	<b>Subindex</b>	TC Settings Ch.2	RW	0x1B (27 <sub>dec</sub> )
	8010:01	Enable user scale	RW	0x00 (0 <sub>dec</sub> )
	8010:02	Presentation	RW	0x00 (0 <sub>dec</sub> )
	8010:05	Siemens bits	RW	0x00 (0 <sub>dec</sub> )
	8010:06	Enable filter	RW	0x00 (0 <sub>dec</sub> )
	8010:07	Enable limit 1	RW	0x00 (0 <sub>dec</sub> )
	8010:08	Enable limit 2	RW	0x00 (0 <sub>dec</sub> )
	8010:0A	Enable user calibration	RW	0x00 (0 <sub>dec</sub> )
	8010:0B	Enable vendor calibration	RW	0x01 (1 <sub>dec</sub> )
	8010:0C	Coldjunction compensation	RW	0x00 (0 <sub>dec</sub> )
	8010:0E	Swap limit bits	RW	0x00 (0 <sub>dec</sub> )
	8010:11	User scale offset	RW	0x0000 (0 <sub>dec</sub> )
	8010:12	User scale gain	RW	0x00010000 (65536 <sub>dec</sub> )
	8010:13	Limit 1	RW	0x0000 (0 <sub>dec</sub> )
	8010:14	Limit 2	RW	0x0000 (0 <sub>dec</sub> )
	8010:15	Filter settings	RW	0x0000 (0 <sub>dec</sub> )
	8010:16	Calibration interval	RW	0x0000 (0 <sub>dec</sub> )
	8010:17	User calibration offset	RW	0x0000 (0 <sub>dec</sub> )
	8010:18	User calibration gain	RW	0x4000 (16384 <sub>dec</sub> )
	8010:19	Sensor type	RW	0x0000 (0 <sub>dec</sub> )
	8010:1B	Wire calibration 1/32 Ohm	RW	0x0000 (0 <sub>dec</sub> )

Index (hex)	Name	Flags	Default value
801E:0 [▶ 102]	<b>Subindex</b>	TC Internal data Ch.2	RO 0x05 (5 <sub>dec</sub> )
	801E:01	ADC raw value TC	RO 0x00000000 (0 <sub>dec</sub> )
	801E:02	ADC raw value PT1000	RO 0x00000000 (0 <sub>dec</sub> )
	801E:03	CJ temperature	RO 0x0000 (0 <sub>dec</sub> )
	801E:04	CJ voltage	RO 0x0000 (0 <sub>dec</sub> )
	801E:05	CJ resistor	RO 0x0000 (0 <sub>dec</sub> )
801F:0 [▶ 102]	<b>Subindex</b>	TC Vendor data Ch.2	RW 0x04 (4 <sub>dec</sub> )
	801F:01	Calibration offset TC	RW 0x0000 (0 <sub>dec</sub> )
	801F:02	Calibration gain TC	RW 0x4000 (16384 <sub>dec</sub> )
	801F:03	Calibration offset CJ	RW 0x0000 (0 <sub>dec</sub> )
	801F:04	Calibration gain CJ	RW 0x4000 (16384 <sub>dec</sub> )
8020:0 [▶ 90]	<b>Subindex</b>	TC Settings Ch.3	RW 0x1B (27 <sub>dec</sub> )
	8020:01	Enable user scale	RW 0x00 (0 <sub>dec</sub> )
	8020:02	Presentation	RW 0x00 (0 <sub>dec</sub> )
	8020:05	Siemens bits	RW 0x00 (0 <sub>dec</sub> )
	8020:06	Enable filter	RW 0x00 (0 <sub>dec</sub> )
	8020:07	Enable limit 1	RW 0x00 (0 <sub>dec</sub> )
	8020:08	Enable limit 2	RW 0x00 (0 <sub>dec</sub> )
	8020:0A	Enable user calibration	RW 0x00 (0 <sub>dec</sub> )
	8020:0B	Enable vendor calibration	RW 0x01 (1 <sub>dec</sub> )
	8020:0C	Coldjunction compensation	RW 0x00 (0 <sub>dec</sub> )
	8020:0E	Swap limit bits	RW 0x00 (0 <sub>dec</sub> )
	8020:11	User scale offset	RW 0x0000 (0 <sub>dec</sub> )
	8020:12	User scale gain	RW 0x00010000 (65536 <sub>dec</sub> )
	8020:13	Limit 1	RW 0x0000 (0 <sub>dec</sub> )
	8020:14	Limit 2	RW 0x0000 (0 <sub>dec</sub> )
	8020:15	Filter settings	RW 0x0000 (0 <sub>dec</sub> )
	8020:16	Calibration interval	RW 0x0000 (0 <sub>dec</sub> )
	8020:17	User calibration offset	RW 0x0000 (0 <sub>dec</sub> )
	8020:18	User calibration gain	RW 0x4000 (16384 <sub>dec</sub> )
	8020:19	Sensor type	RW 0x0000 (0 <sub>dec</sub> )
8020:1B	Wire calibration 1/32 Ohm	RW 0x0000 (0 <sub>dec</sub> )	
802E:0 [▶ 102]	<b>Subindex</b>	TC Internal data Ch.3	RO 0x05 (5 <sub>dec</sub> )
	802E:01	ADC raw value TC	RO 0x00000000 (0 <sub>dec</sub> )
	802E:02	ADC raw value PT1000	RO 0x00000000 (0 <sub>dec</sub> )
	802E:03	CJ temperature	RO 0x0000 (0 <sub>dec</sub> )
	802E:04	CJ voltage	RO 0x0000 (0 <sub>dec</sub> )
	802E:05	CJ resistor	RO 0x0000 (0 <sub>dec</sub> )
802F:0 [▶ 102]	<b>Subindex</b>	TC Vendor data Ch.3	RW 0x04 (4 <sub>dec</sub> )
	802F:01	Calibration offset TC	RW 0x0000 (0 <sub>dec</sub> )
	802F:02	Calibration gain TC	RW 0x4000 (16384 <sub>dec</sub> )
	802F:03	Calibration offset CJ	RW 0x0000 (0 <sub>dec</sub> )
	802F:04	Calibration gain CJ	RW 0x4000 (16384 <sub>dec</sub> )

Index (hex)		Name	Flags	Default value
8030:0 [▶ 92]	<b>Subindex</b>	TC Settings Ch.4	RW	0x1B (27 <sub>dec</sub> )
	8030:01	Enable user scale	RW	0x00 (0 <sub>dec</sub> )
	8030:02	Presentation	RW	0x00 (0 <sub>dec</sub> )
	8030:05	Siemens bits	RW	0x00 (0 <sub>dec</sub> )
	8030:06	Enable filter	RW	0x00 (0 <sub>dec</sub> )
	8030:07	Enable limit 1	RW	0x00 (0 <sub>dec</sub> )
	8030:08	Enable limit 2	RW	0x00 (0 <sub>dec</sub> )
	8030:0A	Enable user calibration	RW	0x00 (0 <sub>dec</sub> )
	8030:0B	Enable vendor calibration	RW	0x01 (1 <sub>dec</sub> )
	8030:0C	Coldjunction compensation	RW	0x00 (0 <sub>dec</sub> )
	8030:0E	Swap limit bits	RW	0x00 (0 <sub>dec</sub> )
	8030:11	User scale offset	RW	0x0000 (0 <sub>dec</sub> )
	8030:12	User scale gain	RW	0x00010000 (65536 <sub>dec</sub> )
	8030:13	Limit 1	RW	0x0000 (0 <sub>dec</sub> )
	8030:14	Limit 2	RW	0x0000 (0 <sub>dec</sub> )
	8030:15	Filter settings	RW	0x0000 (0 <sub>dec</sub> )
	8030:16	Calibration interval	RW	0x0000 (0 <sub>dec</sub> )
	8030:17	User calibration offset	RW	0x0000 (0 <sub>dec</sub> )
	8030:18	User calibration gain	RW	0x4000 (16384 <sub>dec</sub> )
	8030:19	Sensor type	RW	0x0000 (0 <sub>dec</sub> )
	8030:1B	Wire calibration 1/32 Ohm	RW	0x0000 (0 <sub>dec</sub> )
803E:0 [▶ 102]	<b>Subindex</b>	TC Internal data Ch.4	RO	0x05 (5 <sub>dec</sub> )
	803E:01	ADC raw value TC	RO	0x00000000 (0 <sub>dec</sub> )
	803E:02	ADC raw value PT1000	RO	0x00000000 (0 <sub>dec</sub> )
	803E:03	CJ temperature	RO	0x0000 (0 <sub>dec</sub> )
	803E:04	CJ voltage	RO	0x0000 (0 <sub>dec</sub> )
	803E:05	CJ resistor	RO	0x0000 (0 <sub>dec</sub> )
803F:0 [▶ 103]	<b>Subindex</b>	TC Vendor data Ch.4	RW	0x04 (4 <sub>dec</sub> )
	803F:01	Calibration offset TC	RW	0x0000 (0 <sub>dec</sub> )
	803F:02	Calibration gain TC	RW	0x4000 (16384 <sub>dec</sub> )
	803F:03	Calibration offset CJ	RW	0x0000 (0 <sub>dec</sub> )
	803F:04	Calibration gain CJ	RW	0x4000 (16384 <sub>dec</sub> )
F000:0 [▶ 103]	<b>Subindex</b>	Modular device profile	RO	0x02 (2 <sub>dec</sub> )
	F000:01	Module index distance	RO	0x0010 (16 <sub>dec</sub> )
	F000:02	Maximum number of modules	RO	0x0004 (4 <sub>dec</sub> )
F008 [▶ 103]		Code word	RW	0x00000000 (0 <sub>dec</sub> )
F010:0 [▶ 103]	<b>Subindex</b>	Module list	RW	0x04 (4 <sub>dec</sub> )
	F010:01	SubIndex 001	RW	0x0000014A (330 <sub>dec</sub> )
	F010:02	SubIndex 002	RW	0x0000014A (330 <sub>dec</sub> )
	F010:03	SubIndex 003	RW	0x0000014A (330 <sub>dec</sub> )
	F010:04	SubIndex 004	RW	0x0000014A (330 <sub>dec</sub> )
F080:0 [▶ 103]	<b>Subindex</b>	Channel Enable	RO	0x04 (4 <sub>dec</sub> )
	F080:01	SubIndex 001	RW	0xFF (255 <sub>dec</sub> )
	F080:02	SubIndex 002	RW	0xFF (255 <sub>dec</sub> )
	F080:03	SubIndex 003	RW	0xFF (255 <sub>dec</sub> )
	F080:04	SubIndex 004	RW	0xFF (255 <sub>dec</sub> )

## Key

Flags:

RO (Read Only): this object can be read only

RW (Read/Write): this object can be read and written to

## 7.7 EP3314 - object description and parameterization

### **i** EtherCAT XML Device Description

The display matches that of the CoE objects from the EtherCAT XML Device Description. We recommend downloading the latest XML file from the download area of the Beckhoff website and installing it according to installation instructions.

### **i** Parameterization via the CoE list (CAN over EtherCAT)

The EtherCAT device is parameterized via the CoE - Online tab (double-click on the respective object) or via the Process Data tab (allocation of PDOs).

### Introduction

The CoE overview contains objects for different intended applications:

- Objects required for parameterization during commissioning
- Objects intended for regular operation [▶ 93], e.g. through ADS access
- Objects for indicating internal settings [▶ 87] (may be fixed)
- Further profile-specific objects [▶ 99] indicating inputs, outputs and status information

The following section first describes the objects required for normal operation, followed by a complete overview of missing objects.

### 7.7.1 Objects to be parameterized during commissioning

#### Index 1011: Restore default parameters

Index (hex)	Name	Meaning	Data type	Flags	Default
1011:0	Restore default parameters	Restore default parameters	UINT8	RO	0x01 (1 <sub>dec</sub> )
1011:01	SubIndex 001	If this object is set to " <b>0x64616F6C</b> " in the set value dialog, all backup objects are reset to their delivery state.	UINT32	RW	0x00000000 (0 <sub>dec</sub> )

## Index 8000: TC Settings Ch.1

Index (hex)	Name	Meaning	Data type	Flags	Default
8000:0	TC Settings Ch.1	Maximum subindex	UINT8	RO	0x1B (27 <sub>dec</sub> )
8000:01	Enable user scale	Activates user scaling	BOOLEAN	RW	0x00 (0 <sub>dec</sub> )
8000:02	Presentation	Presentation of the measured value	BIT3	RW	0x00 (0 <sub>dec</sub> )
		0 Signed, in two's complement			
		1 Most significant bit as sign			
		2 High-resolution (1/100 °C steps)			
8000:05	Siemens bits	The S5 bits are displayed in the three low-order bits	BOOLEAN	RW	0x00 (0 <sub>dec</sub> )
8000:06	Enable filter	This parameter is without effect. The filter is always enabled.	BOOLEAN	RW	0x00 (0 <sub>dec</sub> )
8000:07	Enable limit 1	Activates limit check for limit 1	BOOLEAN	RW	0x00 (0 <sub>dec</sub> )
8000:08	Enable limit 2	Activates limit check for limit 2	BOOLEAN	RW	0x00 (0 <sub>dec</sub> )
8000:0A	Enable user calibration	Activates user calibration	BOOLEAN	RW	0x00 (0 <sub>dec</sub> )
8000:0B	Enable vendor calibration	Activates vendor calibration	BOOLEAN	RW	0x01 (1 <sub>dec</sub> )
8000:0C	Cold junction compensation	Cold junction compensation	BIT2	RW	0x00 (0 <sub>dec</sub> )
		0 Cold junction compensation takes place via the Pt1000 in the plug connector.			
		1 Cold junction compensation is not active.			
		2 Cold junction compensation takes place via the process data.			
		3 Same as value 0.			
8000:0E	Swap limit bits	Swaps the two limit bits, in order to achieve compatibility with older hardware versions.	BOOLEAN	RW	0x00 (0 <sub>dec</sub> )
8000:11	User scale offset	User scaling: Offset	INT16	RW	0x0000 (0 <sub>dec</sub> )
8000:12	User scale gain	User scaling: Gain	INT32	RW	0x00010000 (65536 <sub>dec</sub> )
8000:13	Limit 1	Value for limit 1	INT16	RW	0x0000 (0 <sub>dec</sub> )
8000:14	Limit 2	Value for limit 2	INT16	RW	0x0000 (0 <sub>dec</sub> )
8000:15	Filter settings	Filter settings (Ch1. applies to all channels)	UINT16	RW	0x0000 (0 <sub>dec</sub> )
		0 50 Hz			
		1 60 Hz			
		2 100 Hz			
		3 500 Hz			
		4 1 kHz,			
		5 2 kHz			
		6 3.75 kHz			
		7 7.5 kHz			
		8 15 kHz			
		9 30 kHz			
		10 5 Hz			
11 10 Hz					
8000:16	Calibration interval	reserved	UINT16	RW	0x0000 (0 <sub>dec</sub> )
8000:17	User calibration offset	User calibration: Offset	INT16	RW	0x0000 (0 <sub>dec</sub> )
8000:18	User calibration gain	User calibration: Gain	UINT16	RW	0x4000 (16384 <sub>dec</sub> )



**Index 8000: TC Settings Ch.1**

Index (hex)	Name	Meaning	Data type	Flags	Default	
8000:19	Sensor type	Thermocouple	UINT16	RW	0x0000 (0 <sub>dec</sub> )	
		0				Type K -200 °C to 1370 °C
		1				Type J -100°C to 1200°C
		2				Type L 0°C to 900°C
		3				Type E -100°C to 1000°C
		4				Type T -200°C to 400°C
		5				Type N -100°C to 1300°C
		6				Type U 0°C to 600°C
		7				Type B 600°C to 1800°C
		8				Type R 0°C to 1767°C
		9				Type S 0°C to 1760°C
		10				Type C 0°C to 2320°C
		100				± 30 mV (1 µV resolution)
101	± 60 mV (2 µV resolution)					
102	± 75 mV (4 µV resolution)					
8000:1B	Wire calibration 1/32 ohm	Only for 2-wire measurements: contains the resistance of the supply line for the temperature sensor (in 1/32 ohm).	INT16	RW	0x0000 (0 <sub>dec</sub> )	

**Index 8010: TC Settings Ch.2**

Index (hex)	Name	Meaning	Data type	Flags	Default	
8010:0	TC Settings Ch.2	Maximum subindex	UINT8	RO	0x1B (27 <sub>dec</sub> )	
8010:01	Enable user scale	Activates user scaling	BOOLEAN	RW	0x00 (0 <sub>dec</sub> )	
8010:02	Presentation	Presentation of the measured value	BIT3	RW	0x00 (0 <sub>dec</sub> )	
		0				Signed, in two's complement
		1				Most significant bit as sign
2	High-resolution (1/100 °C steps)					
8010:05	Siemens bits	The S5 bits are displayed in the three low-order bits	BOOLEAN	RW	0x00 (0 <sub>dec</sub> )	
8010:06	Enable filter	This parameter is without effect. The filter is always enabled.	BOOLEAN	RW	0x00 (0 <sub>dec</sub> )	
8010:07	Enable limit 1	Activates limit check for limit 1	BOOLEAN	RW	0x00 (0 <sub>dec</sub> )	
8010:08	Enable limit 2	Activates limit check for limit 2	BOOLEAN	RW	0x00 (0 <sub>dec</sub> )	
8010:0A	Enable user calibration	Activates user calibration	BOOLEAN	RW	0x00 (0 <sub>dec</sub> )	
8010:0B	Enable vendor calibration	Activates vendor calibration	BOOLEAN	RW	0x01 (1 <sub>dec</sub> )	
8010:0C	Cold junction compensation	Cold junction compensation	BIT2	RW	0x00 (0 <sub>dec</sub> )	
		0				Cold junction compensation takes place via the Pt1000 in the plug connector.
		1				Cold junction compensation is not active.
		2				Cold junction compensation takes place via the process data.
3	Cold junction compensation takes place via the Pt1000 in the plug connector of channel 1.					
8010:0E	Swap limit bits	Swaps the two limit bits, in order to achieve compatibility with older hardware versions.	BOOLEAN	RW	0x00 (0 <sub>dec</sub> )	
8010:11	User scale offset	User scaling: Offset	INT16	RW	0x0000 (0 <sub>dec</sub> )	
8010:12	User scale gain	User scaling: Gain	INT32	RW	0x00010000 (65536 <sub>dec</sub> )	
8010:13	Limit 1	Value for limit 1	INT16	RW	0x0000 (0 <sub>dec</sub> )	
8010:14	Limit 2	Value for limit 2	INT16	RW	0x0000 (0 <sub>dec</sub> )	

## Index 8010: TC Settings Ch.2

Index (hex)	Name	Meaning	Data type	Flags	Default
8010:15	Filter settings	This parameter is without effect. The respective parameter of channel 1 applies to all channels: <a href="#">0x8000:15 "Filter settings" [► 88]</a> .	UINT16	RW	0x0000 (0 <sub>dec</sub> )
8010:16	Calibration interval	reserved	UINT16	RW	0x0000 (0 <sub>dec</sub> )
8010:17	User calibration offset	User calibration: Offset	INT16	RW	0x0000 (0 <sub>dec</sub> )
8010:18	User calibration gain	User calibration: Gain	UINT16	RW	0x4000 (16384 <sub>dec</sub> )
8010:19	Sensor type	Thermocouple 0 Type K -200 °C to 1370 °C 1 Type J -100°C to 1200°C 2 Type L 0°C to 900°C 3 Type E -100°C to 1000°C 4 Type T -200°C to 400°C 5 Type N -100°C to 1300°C 6 Type U 0°C to 600°C 7 Type B 600°C to 1800°C 8 Type R 0°C to 1767°C 9 Type S 0°C to 1760°C 10 Type C 0°C to 2320°C 100 ± 30 mV (1 µV resolution) 101 ± 60 mV (2 µV resolution) 102 ± 75 mV (4 µV resolution)	UINT16	RW	0x0000 (0 <sub>dec</sub> )
8010:1B	Wire calibration 1/32 Ohm	Only for 2-wire measurements: contains the resistance of the supply line for the temperature sensor (in 1/32 ohm).	INT16	RW	0x0000 (0 <sub>dec</sub> )

## Index 8020: TC Settings Ch.3

Index (hex)	Name	Meaning	Data type	Flags	Default
8020:0	TC Settings Ch.3	Maximum subindex	UINT8	RO	0x1B (27 <sub>dec</sub> )
8020:01	Enable user scale	Activates user scaling	BOOLEAN	RW	0x00 (0 <sub>dec</sub> )
8020:02	Presentation	Presentation of the measured value 0 Signed, in two's complement 1 Most significant bit as sign 2 High-resolution (1/100 °C steps)	BIT3	RW	0x00 (0 <sub>dec</sub> )
8020:05	Siemens bits	The S5 bits are displayed in the three low-order bits	BOOLEAN	RW	0x00 (0 <sub>dec</sub> )
8020:06	Enable filter	This parameter is without effect. The filter is always enabled.	BOOLEAN	RW	0x00 (0 <sub>dec</sub> )
8020:07	Enable limit 1	Activates limit check for limit 1	BOOLEAN	RW	0x00 (0 <sub>dec</sub> )
8020:08	Enable limit 2	Activates limit check for limit 2	BOOLEAN	RW	0x00 (0 <sub>dec</sub> )
8020:0A	Enable user calibration	Activates user calibration	BOOLEAN	RW	0x00 (0 <sub>dec</sub> )
8020:0B	Enable vendor calibration	Activates vendor calibration	BOOLEAN	RW	0x01 (1 <sub>dec</sub> )

**Index 8020: TC Settings Ch.3**

Index (hex)	Name	Meaning	Data type	Flags	Default
8020:0C	Cold junction compensation	Cold junction compensation	BIT2	RW	0x00 (0 <sub>dec</sub> )
		0 Cold junction compensation takes place via the Pt1000 in the plug connector.			
		1 Cold junction compensation is not active.			
		2 Cold junction compensation takes place via the process data.			
		3 Cold junction compensation takes place via the Pt1000 in the plug connector of channel 1.			
8020:0E	Swap limit bits	Swaps the two limit bits, in order to achieve compatibility with older hardware versions.	BOOLEAN	RW	0x00 (0 <sub>dec</sub> )
8020:11	User scale offset	User scaling: Offset	INT16	RW	0x0000 (0 <sub>dec</sub> )
8020:12	User scale gain	User scaling: Gain	INT32	RW	0x00010000 (65536 <sub>dec</sub> )
8020:13	Limit 1	Value for limit 1	INT16	RW	0x0000 (0 <sub>dec</sub> )
8020:14	Limit 2	Value for limit 2	INT16	RW	0x0000 (0 <sub>dec</sub> )
8020:15	Filter settings	This parameter is without effect. The respective parameter of channel 1 applies to all channels: <a href="#">0x8000:15 "Filter settings" [► 88]</a> .	UINT16	RW	0x0000 (0 <sub>dec</sub> )
8020:16	Calibration interval	reserved	UINT16	RW	0x0000 (0 <sub>dec</sub> )
8020:17	User calibration offset	User calibration: Offset	INT16	RW	0x0000 (0 <sub>dec</sub> )
8020:18	User calibration gain	User calibration: Gain	UINT16	RW	0x4000 (16384 <sub>dec</sub> )
8020:19	Sensor type	Thermocouple	UINT16	RW	0x0000 (0 <sub>dec</sub> )
		0 Type K -200 °C to 1370 °C			
		1 Type J -100°C to 1200°C			
		2 Type L 0°C to 900°C			
		3 Type E -100°C to 1000°C			
		4 Type T -200°C to 400°C			
		5 Type N -100°C to 1300°C			
		6 Type U 0°C to 600°C			
		7 Type B 600°C to 1800°C			
		8 Type R 0°C to 1767°C			
		9 Type S 0°C to 1760°C			
		10 Type C 0°C to 2320°C			
		100 ± 30 mV (1 µV resolution)			
		101 ± 60 mV (2 µV resolution)			
102 ± 75 mV (4 µV resolution)					
8020:1B	Wire calibration 1/32 ohm	Only for 2-wire measurements: contains the resistance of the supply line for the temperature sensor (in 1/32 ohm).	INT16	RW	0x0000 (0 <sub>dec</sub> )

## Index 8030: TC Settings Ch.4

Index (hex)	Name	Meaning	Data type	Flags	Default	
8030:0	TC Settings Ch.4	Maximum subindex	UINT8	RO	0x1B (27 <sub>dec</sub> )	
8030:01	Enable user scale	Activates user scaling	BOOLEAN	RW	0x00 (0 <sub>dec</sub> )	
8030:02	Presentation	Presentation of the measured value		BIT3	RW	0x00 (0 <sub>dec</sub> )
		0	Signed, in two's complement			
		1	Most significant bit as sign			
		2	High-resolution (1/100 °C steps)			
8030:05	Siemens bits	The S5 bits are displayed in the three low-order bits	BOOLEAN	RW	0x00 (0 <sub>dec</sub> )	
8030:06	Enable filter	This parameter is without effect. The filter is always enabled.	BOOLEAN	RW	0x00 (0 <sub>dec</sub> )	
8030:07	Enable limit 1	Activates limit check for limit 1	BOOLEAN	RW	0x00 (0 <sub>dec</sub> )	
8030:08	Enable limit 2	Activates limit check for limit 2	BOOLEAN	RW	0x00 (0 <sub>dec</sub> )	
8030:0A	Enable user calibration	Activates user calibration	BOOLEAN	RW	0x00 (0 <sub>dec</sub> )	
8030:0B	Enable vendor calibration	Activates vendor calibration	BOOLEAN	RW	0x01 (1 <sub>dec</sub> )	
8030:0C	Cold junction compensation	Cold junction compensation		BIT2	RW	0x00 (0 <sub>dec</sub> )
		0	Cold junction compensation takes place via the Pt1000 in the plug connector.			
		1	Cold junction compensation is not active.			
		2	Cold junction compensation takes place via the process data.			
		3	Cold junction compensation takes place via the Pt1000 in the plug connector of channel 1.			
8030:0E	Swap limit bits	Swaps the two limit bits, in order to achieve compatibility with older hardware versions.	BOOLEAN	RW	0x00 (0 <sub>dec</sub> )	
8030:11	User scale offset	User scaling: Offset	INT16	RW	0x0000 (0 <sub>dec</sub> )	
8030:12	User scale gain	User scaling: Gain	INT32	RW	0x00010000 (65536 <sub>dec</sub> )	
8030:13	Limit 1	Value for limit 1	INT16	RW	0x0000 (0 <sub>dec</sub> )	
8030:14	Limit 2	Value for limit 2	INT16	RW	0x0000 (0 <sub>dec</sub> )	
8030:15	Filter settings	This parameter is without effect. The respective parameter of channel 1 applies to all channels: <a href="#">0x8000:15 "Filter settings" [► 88]</a> .	UINT16	RW	0x0000 (0 <sub>dec</sub> )	
8030:16	Calibration interval	reserved	UINT16	RW	0x0000 (0 <sub>dec</sub> )	
8030:17	User calibration offset	User calibration: Offset	INT16	RW	0x0000 (0 <sub>dec</sub> )	
8030:18	User calibration gain	User calibration: Gain	UINT16	RW	0x4000 (16384 <sub>dec</sub> )	

## Index 8030: TC Settings Ch.4

Index (hex)	Name	Meaning	Data type	Flags	Default	
8030:19	Sensor type	Thermocouple		UINT16	RW	0x0000 (0 <sub>dec</sub> )
		0	Type K -200 °C to 1370 °C			
		1	Type J -100°C to 1200°C			
		2	Type L 0°C to 900°C			
		3	Type E -100°C to 1000°C			
		4	Type T -200°C to 400°C			
		5	Type N -100°C to 1300°C			
		6	Type U 0°C to 600°C			
		7	Type B 600°C to 1800°C			
		8	Type R 0°C to 1767°C			
		9	Type S 0°C to 1760°C			
		10	Type C 0°C to 2320°C			
		100	± 30 mV (1 µV resolution)			
101	± 60 mV (2 µV resolution)					
102	± 75 mV (4 µV resolution)					
8030:1B	Wire calibration 1/32 ohm	Only for 2-wire measurements: contains the resistance of the supply line for the temperature sensor (in 1/32 ohm).	INT16	RW	0x0000 (0 <sub>dec</sub> )	

## 7.7.2 Objects for regular operation

The EP3314 has no such objects.

## 7.7.3 Standard objects (0x1000-0x1FFF)

The standard objects have the same meaning for all EtherCAT slaves.

### Index 1000: Device type

Index (hex)	Name	Meaning	Data type	Flags	Default
1000:0	Device type	Device type of the EtherCAT slave: The Low-Word contains the CoE profile used (5001). The High-Word contains the module profile according to the modular device profile.	UINT32	RO	0x014A1389 (21631881 <sub>dec</sub> )

### Index 1008: Device name

Index (hex)	Name	Meaning	Data type	Flags	Default
1008:0	Device name	Device name of the EtherCAT slave	STRING	RO	EP3314-0002

### Index 1009: Hardware version

Index (hex)	Name	Meaning	Data type	Flags	Default
1009:0	Hardware version	Hardware version of the EtherCAT slave	STRING	RO	00

### Index 100A: Software version

Index (hex)	Name	Meaning	Data type	Flags	Default
100A:0	Software version	Firmware version of the EtherCAT slave	STRING	RO	01

### Index 1018: Identity

Index (hex)	Name	Meaning	Data type	Flags	Default
1018:0	Identity	Information for identifying the slave	UINT8	RO	0x04 (4 <sub>dec</sub> )
1018:01	Vendor ID	Vendor ID of the EtherCAT slave	UINT32	RO	0x00000002 (2 <sub>dec</sub> )
1018:02	Product code	Product code of the EtherCAT slave	UINT32	RO	0x0CF24052 (217202770 <sub>dec</sub> )
1018:03	Revision	Revision number of the EtherCAT slave; the low word (bit 0-15) indicates the special terminal number, the high word (bit 16-31) refers to the device description	UINT32	RO	0x00100002 (1048578 <sub>dec</sub> )
1018:04	Serial number	Serial number of the EtherCAT slave; the low byte (bit 0-7) of the low word contains the year of production, the high byte (bit 8-15) of the low word contains the week of production, the high word (bit 16-31) is 0	UINT32	RO	0x00000000 (0 <sub>dec</sub> )

### Index 10F0: Backup parameter handling

Index (hex)	Name	Meaning	Data type	Flags	Default
10F0:0	Backup parameter handling	Information for standardized loading and saving of backup entries	UINT8	RO	0x01 (1 <sub>dec</sub> )
10F0:01	Checksum	Checksum across all backup entries of the EtherCAT slave	UINT32	RO	0x00000000 (0 <sub>dec</sub> )

### Index 1600: TC RxPDO-Map Outputs Ch.1

Index (hex)	Name	Meaning	Data type	Flags	Default
1600:0	TC RxPDO-Map Outputs Ch.1	PDO Mapping RxPDO 1	UINT8	RO	0x01 (1 <sub>dec</sub> )
1600:01	SubIndex 001	1. PDO Mapping entry (object 0x7000 (TC Outputs Ch.1), entry 0x11 (CJCompensation))	UINT32	RO	0x7000:11, 16

**Index 1601: TC RxPDO-Map Outputs Ch.2**

Index (hex)	Name	Meaning	Data type	Flags	Default
1601:0	TC RxPDO-Map Outputs Ch.2	PDO Mapping RxPDO 2	UINT8	RO	0x01 (1 <sub>dec</sub> )
1601:01	SubIndex 001	1. PDO Mapping entry (object 0x7010 (TC Outputs Ch.2), entry 0x11 (CJCompensation))	UINT32	RO	0x7010:11, 16

**Index 1602: TC RxPDO-Map Outputs Ch.3**

Index (hex)	Name	Meaning	Data type	Flags	Default
1602:0	TC RxPDO-Map Outputs Ch.3	PDO Mapping RxPDO 3	UINT8	RO	0x01 (1 <sub>dec</sub> )
1602:01	SubIndex 001	1. PDO Mapping entry (object 0x7020 (TC Outputs Ch.3), entry 0x11 (CJCompensation))	UINT32	RO	0x7020:11, 16

**Index 1603: TC RxPDO-Map Outputs Ch.4**

Index (hex)	Name	Meaning	Data type	Flags	Default
1603:0	TC RxPDO-Map Outputs Ch.4	PDO Mapping RxPDO 4	UINT8	RO	0x01 (1 <sub>dec</sub> )
1603:01	SubIndex 001	1. PDO Mapping entry (object 0x7030 (TC Outputs Ch.4), entry 0x11 (CJCompensation))	UINT32	RO	0x7030:11, 16

**Index 1A00: TC TxPDO-Map TCInputs Ch.1**

Index (hex)	Name	Meaning	Data type	Flags	Default
1A00:0	TC TxPDO-Map TCInputs Ch.1	PDO Mapping TxPDO 1	UINT8	RO	0x0A (10 <sub>dec</sub> )
1A00:01	SubIndex 001	1. PDO Mapping entry (object 0x6000 (TC Inputs Ch.1), entry 0x01 (Underrange))	UINT32	RO	0x6000:01, 1
1A00:02	SubIndex 002	2. PDO Mapping entry (object 0x6000 (TC Inputs Ch.1), entry 0x02 (Overrange))	UINT32	RO	0x6000:02, 1
1A00:03	SubIndex 003	3. PDO Mapping entry (object 0x6000 (TC Inputs Ch.1), entry 0x03 (Limit 1))	UINT32	RO	0x6000:03, 2
1A00:04	SubIndex 004	4. PDO Mapping entry (object 0x6000 (TC Inputs Ch.1), entry 0x05 (Limit 2))	UINT32	RO	0x6000:05, 2
1A00:05	SubIndex 005	5. PDO Mapping entry (object 0x6000 (TC Inputs Ch.1), entry 0x07 (Error))	UINT32	RO	0x6000:07, 1
1A00:06	SubIndex 006	6. PDO Mapping entry (6 bits align)	UINT32	RO	0x0000:00, 6
1A00:07	SubIndex 007	7. PDO Mapping entry (object 0x6000 (TC Inputs Ch.1), entry 0x0E (Sync error))	UINT32	RO	0x6000:0E, 1
1A00:08	SubIndex 008	8. PDO Mapping entry (object 0x1800, entry 0x07)	UINT32	RO	0x1800:07, 1
1A00:09	SubIndex 009	9. PDO Mapping entry (object 0x1800, entry 0x09)	UINT32	RO	0x1800:09, 1
1A00:0A	SubIndex 010	10. PDO Mapping entry (object 0x6000 (TC Inputs Ch.1), entry 0x11 (Value))	UINT32	RO	0x6000:11, 16

**Index 1A01: TC TxPDO-Map TCInputs Ch.2**

Index (hex)	Name	Meaning	Data type	Flags	Default
1A01:0	TC TxPDO-Map TCInputs Ch.2	PDO Mapping TxPDO 2	UINT8	RO	0x0A (10 <sub>dec</sub> )
1A01:01	SubIndex 001	1. PDO Mapping entry (object 0x6010 (TC Inputs Ch.2), entry 0x01 (Underrange))	UINT32	RO	0x6010:01, 1
1A01:02	SubIndex 002	2. PDO Mapping entry (object 0x6010 (TC Inputs Ch.2), entry 0x02 (Overrange))	UINT32	RO	0x6010:02, 1
1A01:03	SubIndex 003	3. PDO Mapping entry (object 0x6010 (TC Inputs Ch.2), entry 0x03 (Limit 1))	UINT32	RO	0x6010:03, 2
1A01:04	SubIndex 004	4. PDO Mapping entry (object 0x6010 (TC Inputs Ch.2), entry 0x05 (Limit 2))	UINT32	RO	0x6010:05, 2
1A01:05	SubIndex 005	5. PDO Mapping entry (object 0x6010 (TC Inputs Ch.2), entry 0x07 (Error))	UINT32	RO	0x6010:07, 1
1A01:06	SubIndex 006	6. PDO Mapping entry (6 bits align)	UINT32	RO	0x0000:00, 6
1A01:07	SubIndex 007	7. PDO Mapping entry (object 0x6010 (TC Inputs Ch.2), entry 0x0E (Sync error))	UINT32	RO	0x6010:0E, 1
1A01:08	SubIndex 008	8. PDO Mapping entry (object 0x1801, entry 0x07)	UINT32	RO	0x1801:07, 1
1A01:09	SubIndex 009	9. PDO Mapping entry (object 0x1801, entry 0x09)	UINT32	RO	0x1801:09, 1
1A01:0A	SubIndex 010	10. PDO Mapping entry (object 0x6010 (TC Inputs Ch.2), entry 0x11 (Value))	UINT32	RO	0x6010:11, 16

**Index 1A02: TC TxPDO-Map TCInputs Ch.3**

Index (hex)	Name	Meaning	Data type	Flags	Default
1A02:0	TC TxPDO-Map TCInputs Ch.3	PDO Mapping TxPDO 3	UINT8	RO	0x0A (10 <sub>dec</sub> )
1A02:01	SubIndex 001	1. PDO Mapping entry (object 0x6020 (TC Inputs Ch.3), entry 0x01 (Underrange))	UINT32	RO	0x6020:01, 1
1A02:02	SubIndex 002	2. PDO Mapping entry (object 0x6020 (TC Inputs Ch.3), entry 0x02 (Overrange))	UINT32	RO	0x6020:02, 1
1A02:03	SubIndex 003	3. PDO Mapping entry (object 0x6020 (TC Inputs Ch.3), entry 0x03 (Limit 1))	UINT32	RO	0x6020:03, 2
1A02:04	SubIndex 004	4. PDO Mapping entry (object 0x6020 (TC Inputs Ch.3), entry 0x05 (Limit 2))	UINT32	RO	0x6020:05, 2
1A02:05	SubIndex 005	5. PDO Mapping entry (object 0x6020 (TC Inputs Ch.3), entry 0x07 (Error))	UINT32	RO	0x6020:07, 1
1A02:06	SubIndex 006	6. PDO Mapping entry (6 bits align)	UINT32	RO	0x0000:00, 6
1A02:07	SubIndex 007	7. PDO Mapping entry (object 0x6020 (TC Inputs Ch.3), entry 0x0E (Sync error))	UINT32	RO	0x6020:0E, 1
1A02:08	SubIndex 008	8. PDO Mapping entry (object 0x1802, entry 0x07)	UINT32	RO	0x1802:07, 1
1A02:09	SubIndex 009	9. PDO Mapping entry (object 0x1802, entry 0x09)	UINT32	RO	0x1802:09, 1
1A02:0A	SubIndex 010	10. PDO Mapping entry (object 0x6020 (TC Inputs Ch.3), entry 0x11 (Value))	UINT32	RO	0x6020:11, 16

**Index 1A03: TC TxPDO-Map TCInputs Ch.4**

Index (hex)	Name	Meaning	Data type	Flags	Default
1A03:0	TC TxPDO-Map TCInputs Ch.4	PDO Mapping TxPDO 4	UINT8	RO	0x0A (10 <sub>dec</sub> )
1A03:01	SubIndex 001	1. PDO Mapping entry (object 0x6030 (TC Inputs Ch.4), entry 0x01 (Underrange))	UINT32	RO	0x6030:01, 1
1A03:02	SubIndex 002	2. PDO Mapping entry (object 0x6030 (TC Inputs Ch.4), entry 0x02 (Overrange))	UINT32	RO	0x6030:02, 1
1A03:03	SubIndex 003	3. PDO Mapping entry (object 0x6030 (TC Inputs Ch.4), entry 0x03 (Limit 1))	UINT32	RO	0x6030:03, 2
1A03:04	SubIndex 004	4. PDO Mapping entry (object 0x6030 (TC Inputs Ch.4), entry 0x05 (Limit 2))	UINT32	RO	0x6030:05, 2
1A03:05	SubIndex 005	5. PDO Mapping entry (object 0x6030 (TC Inputs Ch.4), entry 0x07 (Error))	UINT32	RO	0x6030:07, 1
1A03:06	SubIndex 006	6. PDO Mapping entry (6 bits align)	UINT32	RO	0x0000:00, 6
1A03:07	SubIndex 007	7. PDO Mapping entry (object 0x6030 (TC Inputs Ch.4), entry 0x0E (Sync error))	UINT32	RO	0x6030:0E, 1
1A03:08	SubIndex 008	8. PDO Mapping entry (object 0x1803, entry 0x07)	UINT32	RO	0x1803:07, 1
1A03:09	SubIndex 009	9. PDO Mapping entry (object 0x1803, entry 0x09)	UINT32	RO	0x1803:09, 1
1A03:0A	SubIndex 010	10. PDO Mapping entry (object 0x6030 (TC Inputs Ch.4), entry 0x11 (Value))	UINT32	RO	0x6030:11, 16

**Index 1C00: Sync manager type**

Index (hex)	Name	Meaning	Data type	Flags	Default
1C00:0	Sync manager type	Using the sync managers	UINT8	RO	0x04 (4 <sub>dec</sub> )
1C00:01	SubIndex 001	Sync-Manager Type Channel 1: Mailbox Write	UINT8	RO	0x01 (1 <sub>dec</sub> )
1C00:02	SubIndex 002	Sync-Manager Type Channel 2: Mailbox Read	UINT8	RO	0x02 (2 <sub>dec</sub> )
1C00:03	SubIndex 003	Sync-Manager Type Channel 3: Process Data Write (Outputs)	UINT8	RO	0x03 (3 <sub>dec</sub> )
1C00:04	SubIndex 004	Sync-Manager Type Channel 4: Process Data Read (Inputs)	UINT8	RO	0x04 (4 <sub>dec</sub> )

**Index 1C12: RxPDO assign**

Index (hex)	Name	Meaning	Data type	Flags	Default
1C12:0	RxPDO assign	PDO Assign Outputs	UINT8	RW	0x00 (0 <sub>dec</sub> )
1C12:01	Subindex 001	1. allocated RxPDO (contains the index of the associated RxPDO mapping object)	UINT16	RW	0x0000 (0 <sub>dec</sub> )
1C12:02	Subindex 002	2. allocated RxPDO (contains the index of the associated RxPDO mapping object)	UINT16	RW	0x0000 (0 <sub>dec</sub> )
1C12:03	Subindex 003	3. allocated RxPDO (contains the index of the associated RxPDO mapping object)	UINT16	RW	0x0000 (0 <sub>dec</sub> )
1C12:04	Subindex 004	4. allocated RxPDO (contains the index of the associated RxPDO mapping object)	UINT16	RW	0x0000 (0 <sub>dec</sub> )

**Index 1C13: TxPDO assign**

Index (hex)	Name	Meaning	Data type	Flags	Default
1C13:0	TxPDO assign	PDO Assign Inputs	UINT8	RW	0x04 (4 <sub>dec</sub> )
1C13:01	Subindex 001	1. allocated TxPDO (contains the index of the associated TxPDO mapping object)	UINT16	RW	0x1A00 (6656 <sub>dec</sub> )
1C13:02	Subindex 002	2. allocated TxPDO (contains the index of the associated TxPDO mapping object)	UINT16	RW	0x1A01 (6657 <sub>dec</sub> )
1C13:03	Subindex 003	3. allocated TxPDO (contains the index of the associated TxPDO mapping object)	UINT16	RW	0x1A02 (6658 <sub>dec</sub> )
1C13:04	Subindex 004	4. allocated TxPDO (contains the index of the associated TxPDO mapping object)	UINT16	RW	0x1A03 (6659 <sub>dec</sub> )



**Index 1C32: SM output parameter**

Index (hex)	Name	Meaning	Data type	Flags	Default
1C32:0	SM output parameter	Synchronization parameters for the outputs	UINT8	RO	0x20 (32 <sub>dec</sub> )
1C32:01	Sync mode	Current synchronization mode: <ul style="list-style-type: none"> <li>• 0: Free Run</li> <li>• 1: Synchronous with SM 2 event</li> <li>• 2: DC-Mode - Synchronous with SYNC0 Event</li> <li>• 3: DC-Mode - Synchronous with SYNC1 event</li> </ul>	UINT16	RW	0x0000 (0 <sub>dec</sub> )
1C32:02	Cycle time	Cycle time (in ns): <ul style="list-style-type: none"> <li>• Free Run: Cycle time of the local timer</li> <li>• Synchronous with SM 2 event: Master cycle time</li> <li>• DC mode: SYNC0/SYNC1 Cycle Time</li> </ul>	UINT32	RW	0x000F4240 (1000000 <sub>dec</sub> )
1C32:03	Shift time	Time between SYNC0 event and output of the outputs (in ns, DC mode only)	UINT32	RO	0x00000000 (0 <sub>dec</sub> )
1C32:04	Sync modes supported	Supported synchronization modes: <ul style="list-style-type: none"> <li>• Bit 0 = 1: free run is supported</li> <li>• Bit 1 = 1: Synchronous with SM 2 event is supported</li> <li>• Bit 2-3 = 01: DC mode is supported</li> <li>• Bit 4-5 = 10: Output shift with SYNC1 event (only DC mode)</li> <li>• Bit 14 = 1: dynamic times (measurement through writing of 0x1C32:08 [▶ 97])</li> </ul>	UINT16	RO	0xC007 (49159 <sub>dec</sub> )
1C32:05	Minimum cycle time	Minimum cycle time (in ns)	UINT32	RO	0x00002710 (10000 <sub>dec</sub> )
1C32:06	Calc and copy time	Minimum time between SYNC0 and SYNC1 event (in ns, DC mode only)	UINT32	RO	0x00000000 (0 <sub>dec</sub> )
1C32:07	Minimum delay time		UINT32	RO	0x00000000 (0 <sub>dec</sub> )
1C32:08	Command	<ul style="list-style-type: none"> <li>• 0: Measurement of the local cycle time is stopped</li> <li>• 1: Measurement of the local cycle time is started</li> </ul> The entries 0x1C32:03 [▶ 97], 0x1C32:05 [▶ 97], 0x1C32:06 [▶ 97], 0x1C32:09 [▶ 97], 0x1C33:03 [▶ 98], 0x1C33:06 [▶ 97], 0x1C33:09 [▶ 98] are updated with the maximum measured values. For a subsequent measurement the measured values are reset	UINT16	RW	0x0000 (0 <sub>dec</sub> )
1C32:09	Maximum Delay time	Time between SYNC1 event and output of the outputs (in ns, DC mode only)	UINT32	RO	0x00000000 (0 <sub>dec</sub> )
1C32:0B	SM event missed counter	Number of missed SM events in OPERATIONAL (DC mode only)	UINT16	RO	0x0000 (0 <sub>dec</sub> )
1C32:0C	Cycle exceeded counter	Number of occasions the cycle time was exceeded in OPERATIONAL (cycle was not completed in time or the next cycle began too early)	UINT16	RO	0x0000 (0 <sub>dec</sub> )
1C32:0D	Shift too short counter	Number of occasions that the interval between SYNC0 and SYNC1 event was too short (DC mode only)	UINT16	RO	0x0000 (0 <sub>dec</sub> )
1C32:20	Sync error	The synchronization was not correct in the last cycle (outputs were output too late; DC mode only)	BOOLEAN	RO	0x00 (0 <sub>dec</sub> )

## Index 1C33: SM input parameter

Index (hex)	Name	Meaning	Data type	Flags	Default
1C33:0	SM input parameter	Synchronization parameters for the inputs	UINT8	RO	0x20 (32 <sub>dec</sub> )
1C33:01	Sync mode	Current synchronization mode: <ul style="list-style-type: none"> <li>• 0: Free Run</li> <li>• 1: Synchronous with SM 3 Event (no outputs available)</li> <li>• 2: DC - Synchronous with SYNC0 Event</li> <li>• 3: DC - Synchron with SYNC1 Event</li> <li>• 34: Synchron with SM 2 Event (outputs available)</li> </ul>	UINT16	RW	0x0000 (0 <sub>dec</sub> )
1C33:02	Cycle time	as <a href="#">0x1C32:02</a> [► 97]	UINT32	RW	0x000F4240 (1000000 <sub>dec</sub> )
1C33:03	Shift time	Time between SYNC0 event and reading of the inputs (in ns, only DC mode)	UINT32	RO	0x00000000 (0 <sub>dec</sub> )
1C33:04	Sync modes supported	Supported synchronization modes: <ul style="list-style-type: none"> <li>• Bit 0: free run is supported</li> <li>• Bit 1: Synchron with SM 2 Event is supported (outputs available)</li> <li>• Bit 1: Synchron with SM 3 Event is supported (no outputs available)</li> <li>• Bit 2-3 = 01: DC mode is supported</li> <li>• Bit 4-5 = 01: input shift through local event (outputs available)</li> <li>• Bit 4-5 = 10: input shift with SYNC1 event (no outputs available)</li> <li>• Bit 14 = 1: dynamic times (measurement through writing of <a href="#">0x1C32:08</a> [► 97] or <a href="#">0x1C33:08</a> [► 98])</li> </ul>	UINT16	RO	0xC007 (49159 <sub>dec</sub> )
1C33:05	Minimum cycle time	as <a href="#">0x1C32:05</a> [► 97]	UINT32	RO	0x00002710 (10000 <sub>dec</sub> )
1C33:06	Calc and copy time	Time between reading of the inputs and availability of the inputs for the master (in ns, only DC mode)	UINT32	RO	0x00000000 (0 <sub>dec</sub> )
1C33:07	Minimum delay time		UINT32	RO	0x00000000 (0 <sub>dec</sub> )
1C33:08	Command	as <a href="#">0x1C32:08</a> [► 97]	UINT16	RW	0x0000 (0 <sub>dec</sub> )
1C33:09	Maximum Delay time	Time between SYNC1 event and reading of the inputs (in ns, only DC mode)	UINT32	RO	0x00000000 (0 <sub>dec</sub> )
1C33:0B	SM event missed counter	as <a href="#">0x1C32:11</a> [► 97]	UINT16	RO	0x0000 (0 <sub>dec</sub> )
1C33:0C	Cycle exceeded counter	as <a href="#">0x1C32:12</a> [► 97]	UINT16	RO	0x0000 (0 <sub>dec</sub> )
1C33:0D	Shift too short counter	as <a href="#">0x1C32:13</a> [► 97]	UINT16	RO	0x0000 (0 <sub>dec</sub> )
1C33:20	Sync error	as <a href="#">0x1C32:32</a> [► 97]	BOOLEAN	RO	0x00 (0 <sub>dec</sub> )

## 7.7.4 Profile-specific objects (0x6000-0xFFFF)

The profile-specific objects have the same meaning for all EtherCAT slaves that support the profile 5001.

### Index 6000: TC Inputs Ch.1

Index (hex)	Name	Meaning	Data type	Flags	Default
6000:0	TC Inputs Ch.1	Maximum subindex	UINT8	RO	0x11 (17 <sub>dec</sub> )
6000:01	Underrange	Is set if the value falls below the operating range of the sensor or the process record contains the lowest possible value.	BOOLEAN	RO	0x00 (0 <sub>dec</sub> )
6000:02	Overrange	Is set if the value exceeds the operating range of the sensor or the process record contains the highest possible value.	BOOLEAN	RO	0x00 (0 <sub>dec</sub> )
6000:03	Limit 1	Only when limit check is active	BIT2	RO	0x00 (0 <sub>dec</sub> )
		1 Value below set limit			
		2 Set limit exceeded			
		3 Set limit reached			
6000:05	Limit 2	Only when limit check is active	BIT2	RO	0x00 (0 <sub>dec</sub> )
		1 Value below set limit			
		2 Set limit exceeded			
		3 Set limit reached			
6000:07	Error	The error bit is set if the process data is invalid (cable break, overrange, underrange)	BOOLEAN	RO	0x00 (0 <sub>dec</sub> )
6000:0E	Sync error	Only in DC: bit is set if the slave is not able to operate synchronous with master, because it cannot keep up with the cycle time.	BOOLEAN	RO	0x00 (0 <sub>dec</sub> )
6000:0F	TxPDO State	Validity of the data of the associated TxPDO	BOOLEAN	RO	0x00 (0 <sub>dec</sub> )
		0 valid			
		1 invalid			
6000:10	TxPDO Toggle	TxPDO toggle is toggled by the slave when the data of the associated TxPDO is updated.	BOOLEAN	RO	0x00 (0 <sub>dec</sub> )
6000:11	Value	Analog input value (resolution in 1/10 °C)	INT16	RO	0x0000 (0 <sub>dec</sub> )

### Index 6010: TC Inputs Ch.2

Index (hex)	Name	Meaning	Data type	Flags	Default
6010:0	TC Inputs Ch.2	Maximum subindex	UINT8	RO	0x11 (17 <sub>dec</sub> )
6010:01	Underrange	Is set if the value falls below the operating range of the sensor or the process record contains the lowest possible value.	BOOLEAN	RO	0x00 (0 <sub>dec</sub> )
6010:02	Overrange	Is set if the value exceeds the operating range of the sensor or the process record contains the highest possible value.	BOOLEAN	RO	0x00 (0 <sub>dec</sub> )
6010:03	Limit 1	Only when limit check is active	BIT2	RO	0x00 (0 <sub>dec</sub> )
		1 Value below set limit			
		2 Set limit exceeded			
		3 Set limit reached			
6010:05	Limit 2	Only when limit check is active	BIT2	RO	0x00 (0 <sub>dec</sub> )
		1 Value below set limit			
		2 Set limit exceeded			
		3 Set limit reached			
6010:07	Error	The error bit is set if the process data is invalid (cable break, overrange, underrange)	BOOLEAN	RO	0x00 (0 <sub>dec</sub> )
6010:0E	Sync error	Only in DC: bit is set if the slave is not able to operate synchronous with master, because it cannot keep up with the cycle time.	BOOLEAN	RO	0x00 (0 <sub>dec</sub> )
6010:0F	TxPDO State	Validity of the data of the associated TxPDO	BOOLEAN	RO	0x00 (0 <sub>dec</sub> )
		0 valid			
		1 invalid			
6010:10	TxPDO Toggle	TxPDO toggle is toggled by the slave when the data of the associated TxPDO is updated.	BOOLEAN	RO	0x00 (0 <sub>dec</sub> )
6010:11	Value	Analog input value (resolution in 1/10 °C)	INT16	RO	0x0000 (0 <sub>dec</sub> )

## Index 6020: TC Inputs Ch.3

Index (hex)	Name	Meaning	Data type	Flags	Default
6020:0	TC Inputs Ch.3	Maximum subindex	UINT8	RO	0x11 (17 <sub>dec</sub> )
6020:01	Underrange	Is set if the value falls below the operating range of the sensor or the process record contains the lowest possible value.	BOOLEAN	RO	0x00 (0 <sub>dec</sub> )
6020:02	Overrange	Is set if the value exceeds the operating range of the sensor or the process record contains the highest possible value.	BOOLEAN	RO	0x00 (0 <sub>dec</sub> )
6020:03	Limit 1	Only when limit check is active	BIT2	RO	0x00 (0 <sub>dec</sub> )
		1 Value below set limit			
		2 Set limit exceeded			
		3 Set limit reached			
6020:05	Limit 2	Only when limit check is active	BIT2	RO	0x00 (0 <sub>dec</sub> )
		1 Value below set limit			
		2 Set limit exceeded			
		3 Set limit reached			
6020:07	Error	The error bit is set if the process data is invalid (cable break, overrange, underrange)	BOOLEAN	RO	0x00 (0 <sub>dec</sub> )
6020:0E	Sync error	Only in DC: bit is set if the slave is not able to operate synchronous with master, because it cannot keep up with the cycle time.	BOOLEAN	RO	0x00 (0 <sub>dec</sub> )
6020:0F	TxPDO State	Validity of the data of the associated TxPDO	BOOLEAN	RO	0x00 (0 <sub>dec</sub> )
		0 valid			
		1 invalid			
6020:10	TxPDO Toggle	TxPDO toggle is toggled by the slave when the data of the associated TxPDO is updated.	BOOLEAN	RO	0x00 (0 <sub>dec</sub> )
6020:11	Value	Analog input value (resolution in 1/10°C)	INT16	RO	0x0000 (0 <sub>dec</sub> )

## Index 6030: TC Inputs Ch.4

Index (hex)	Name	Meaning	Data type	Flags	Default
6030:0	TC Inputs Ch.4	Maximum subindex	UINT8	RO	0x11 (17 <sub>dec</sub> )
6030:01	Underrange	Is set if the value falls below the operating range of the sensor or the process record contains the lowest possible value.	BOOLEAN	RO	0x00 (0 <sub>dec</sub> )
6030:02	Overrange	Is set if the value exceeds the operating range of the sensor or the process record contains the highest possible value.	BOOLEAN	RO	0x00 (0 <sub>dec</sub> )
6030:03	Limit 1	Only when limit check is active	BIT2	RO	0x00 (0 <sub>dec</sub> )
		1 Value below set limit			
		2 Set limit reached			
		3 Set limit exceeded			
6030:05	Limit 2	Only when limit check is active	BIT2	RO	0x00 (0 <sub>dec</sub> )
		1 Value below set limit			
		2 Set limit reached			
		3 Set limit exceeded			
6030:07	Error	The error bit is set if the process data is invalid (cable break, overrange, underrange)	BOOLEAN	RO	0x00 (0 <sub>dec</sub> )
6030:0E	Sync error	Only in DC: bit is set if the slave is not able to operate synchronous with master, because it cannot keep up with the cycle time.	BOOLEAN	RO	0x00 (0 <sub>dec</sub> )
6030:0F	TxPDO State	Validity of the data of the associated TxPDO	BOOLEAN	RO	0x00 (0 <sub>dec</sub> )
		0 valid			
		1 invalid			
6030:10	TxPDO Toggle	TxPDO toggle is toggled by the slave when the data of the associated TxPDO is updated.	BOOLEAN	RO	0x00 (0 <sub>dec</sub> )
6030:11	Value	Analog input value (resolution in 1/10°C)	INT16	RO	0x0000 (0 <sub>dec</sub> )

**Index 7000: TC Outputs Ch.1**

Index (hex)	Name	Meaning	Data type	Flags	Default
7000:0	TC Outputs Ch.1	Maximum subindex	UINT8	RO	0x11 (17 <sub>dec</sub> )
7000:11	CJCompensation	Temperature of the cold junction (resolution in 1/10°C) (index 0x8000:0C [▶ 88], comparison via the process data)	INT16	RO	0x0000 (0 <sub>dec</sub> )

**Index 7010: TC Outputs Ch.2**

Index (hex)	Name	Meaning	Data type	Flags	Default
7010:0	TC Outputs Ch.2	Maximum subindex	UINT8	RO	0x11 (17 <sub>dec</sub> )
7010:11	CJCompensation	Temperature of the cold junction (resolution in 1/10°C) (index 0x8000:0C [▶ 89], comparison via the process data)	INT16	RO	0x0000 (0 <sub>dec</sub> )

**Index 7020: TC Outputs Ch.3**

Index (hex)	Name	Meaning	Data type	Flags	Default
7020:0	TC Outputs Ch.3	Maximum subindex	UINT8	RO	0x11 (17 <sub>dec</sub> )
7020:11	CJCompensation	Temperature of the cold junction (resolution in 1/10°C) (index 0x8020:0C [▶ 90], comparison via the process data)	INT16	RO	0x0000 (0 <sub>dec</sub> )

**Index 7030: TC Outputs Ch.4**

Index (hex)	Name	Meaning	Data type	Flags	Default
7030:0	TC Outputs Ch.4	Maximum subindex	UINT8	RO	0x11 (17 <sub>dec</sub> )
7030:11	CJCompensation	Temperature of the cold junction (resolution in 1/10°C) (index 0x8030:0C [▶ 92], comparison via the process data)	INT16	RO	0x0000 (0 <sub>dec</sub> )

**Index 800E: TC Internal data Ch.1**

Index (hex)	Name	Meaning	Data type	Flags	Default
800E:0	TC Internal data Ch.1	Maximum subindex	UINT8	RO	0x05 (5 <sub>dec</sub> )
800E:01	ADC raw value TC	Raw value of the analog/digital converter for the thermocouple	INT32	RO	0x00000000 (0 <sub>dec</sub> )
800E:02	ADC raw value PT1000	Raw value of the analog/digital converter for the Pt1000	INT32	RO	0x00000000 (0 <sub>dec</sub> )
800E:03	CJ temperature	Cold junction temperature (resolution 1/10 °C)	INT16	RO	0x0000 (0 <sub>dec</sub> )
800E:04	CJ voltage	Cold junction voltage (resolution 1 µV)	INT16	RO	0x0000 (0 <sub>dec</sub> )
800E:05	CJ resistor	Cold junction resistance for Pt1000 temperature sensor (resolution 1/10 ohm)	UINT16	RO	0x0000 (0 <sub>dec</sub> )

**Index 800F: TC Vendor data Ch.1**

Index (hex)	Name	Meaning	Data type	Flags	Default
800F:0	TC Vendor data Ch.1	Maximum subindex	UINT8	RO	0x04 (4 <sub>dec</sub> )
800F:01	Calibration offset TC	Manufacturer calibration for thermocouple: Offset	INT16	RW	0x0000 (0 <sub>dec</sub> )
800F:02	Calibration gain TC	Manufacturer calibration for thermocouple: Gain	UINT16	RW	0x4000 (16384 <sub>dec</sub> )
800F:03	Calibration offset CJ	Manufacturer calibration for cold junction (Pt1000): Offset	INT16	RW	0x0000 (0 <sub>dec</sub> )
800F:04	Calibration gain CJ	Manufacturer calibration for cold junction (Pt1000): Gain	UINT16	RW	0x4000 (16384 <sub>dec</sub> )

**Index 801E: TC Internal data Ch.2**

Index (hex)	Name	Meaning	Data type	Flags	Default
801E:0	TC Internal data Ch.2	Maximum subindex	UINT8	RO	0x05 (5 <sub>dec</sub> )
801E:01	ADC raw value TC	Raw value of the analog/digital converter for the thermocouple	INT32	RO	0x00000000 (0 <sub>dec</sub> )
801E:02	ADC raw value PT1000	Raw value of the analog/digital converter for the Pt1000	INT32	RO	0x00000000 (0 <sub>dec</sub> )
801E:03	CJ temperature	Cold junction temperature (resolution 1/10 °C)	INT16	RO	0x0000 (0 <sub>dec</sub> )
801E:04	CJ voltage	Cold junction voltage (resolution 1 µV)	INT16	RO	0x0000 (0 <sub>dec</sub> )
801E:05	CJ resistor	Cold junction resistance for Pt1000 temperature sensor (resolution 1/10 ohm)	UINT16	RO	0x0000 (0 <sub>dec</sub> )

**Index 801F: TC Vendor data Ch.2**

Index (hex)	Name	Meaning	Data type	Flags	Default
801F:0	TC Vendor data Ch.2	Maximum subindex	UINT8	RO	0x04 (4 <sub>dec</sub> )
801F:01	Calibration offset TC	Manufacturer calibration for thermocouple: Offset	INT16	RW	0x0000 (0 <sub>dec</sub> )
801F:02	Calibration gain TC	Manufacturer calibration for thermocouple: Gain	UINT16	RW	0x4000 (16384 <sub>dec</sub> )
801F:03	Calibration offset CJ	Manufacturer calibration for cold junction (Pt1000): Offset	INT16	RW	0x0000 (0 <sub>dec</sub> )
801F:04	Calibration gain CJ	Manufacturer calibration for cold junction (Pt1000): Gain	UINT16	RW	0x4000 (16384 <sub>dec</sub> )

**Index 802E: TC Internal data Ch.3**

Index (hex)	Name	Meaning	Data type	Flags	Default
802E:0	TC Internal data Ch.3	Maximum subindex	UINT8	RO	0x05 (5 <sub>dec</sub> )
802E:01	ADC raw value TC	Raw value of the analog/digital converter for the thermocouple	INT32	RO	0x00000000 (0 <sub>dec</sub> )
802E:02	ADC raw value PT1000	Raw value of the analog/digital converter for the Pt1000	INT32	RO	0x00000000 (0 <sub>dec</sub> )
802E:03	CJ temperature	Cold junction temperature (resolution 1/10°C)	INT16	RO	0x0000 (0 <sub>dec</sub> )
802E:04	CJ voltage	Cold junction voltage (resolution 1 µV)	INT16	RO	0x0000 (0 <sub>dec</sub> )
802E:05	CJ resistor	Cold junction resistance for Pt1000 temperature sensor (resolution 1/10 ohm)	UINT16	RO	0x0000 (0 <sub>dec</sub> )

**Index 802F: TC Vendor data Ch.3**

Index (hex)	Name	Meaning	Data type	Flags	Default
802F:0	TC Vendor data Ch.3	Maximum subindex	UINT8	RO	0x04 (4 <sub>dec</sub> )
802F:01	Calibration offset TC	Manufacturer calibration for thermocouple: Offset	INT16	RW	0x0000 (0 <sub>dec</sub> )
802F:02	Calibration gain TC	Manufacturer calibration for thermocouple: Gain	UINT16	RW	0x4000 (16384 <sub>dec</sub> )
802F:03	Calibration offset CJ	Manufacturer calibration for cold junction (Pt1000): Offset	INT16	RW	0x0000 (0 <sub>dec</sub> )
802F:04	Calibration gain CJ	Manufacturer calibration for cold junction (Pt1000): Gain	UINT16	RW	0x4000 (16384 <sub>dec</sub> )

**Index 803E: TC Internal data Ch.4**

Index (hex)	Name	Meaning	Data type	Flags	Default
803E:0	TC Internal data Ch.4	Maximum subindex	UINT8	RO	0x05 (5 <sub>dec</sub> )
803E:01	ADC raw value TC	Raw value of the analog/digital converter for the thermocouple	INT32	RO	0x00000000 (0 <sub>dec</sub> )
803E:02	ADC raw value PT1000	Raw value of the analog/digital converter for the Pt1000	INT32	RO	0x00000000 (0 <sub>dec</sub> )
803E:03	CJ temperature	Cold junction temperature (resolution 1/10°C)	INT16	RO	0x0000 (0 <sub>dec</sub> )
803E:04	CJ voltage	Cold junction voltage (resolution 1 µV)	INT16	RO	0x0000 (0 <sub>dec</sub> )
803E:05	CJ resistor	Cold junction resistance for Pt1000 temperature sensor (resolution 1/10 ohm)	UINT16	RO	0x0000 (0 <sub>dec</sub> )

**Index 803F: TC Vendor data Ch.4**

Index (hex)	Name	Meaning	Data type	Flags	Default
803F:0	TC Vendor data Ch.4	Maximum subindex	UINT8	RO	0x04 (4 <sub>dec</sub> )
803F:01	Calibration offset TC	Manufacturer calibration for thermocouple: Offset	INT16	RW	0x0000 (0 <sub>dec</sub> )
803F:02	Calibration gain TC	Manufacturer calibration for thermocouple: Gain	UINT16	RW	0x4000 (16384 <sub>dec</sub> )
803F:03	Calibration offset CJ	Manufacturer calibration for cold junction (Pt1000): Offset	INT16	RW	0x0000 (0 <sub>dec</sub> )
803F:04	Calibration gain CJ	Manufacturer calibration for cold junction (Pt1000): Gain	UINT16	RW	0x4000 (16384 <sub>dec</sub> )

**Index F000: Modular device profile**

Index (hex)	Name	Meaning	Data type	Flags	Default
F000:0	Modular device profile	Maximum subindex	UINT8	RO	0x02 (2 <sub>dec</sub> )
F000:01	Module index distance	Index spacing for the objects of the individual channels	UINT16	RO	0x0010 (16 <sub>dec</sub> )
F000:02	Maximum number of modules	Number of channels	UINT16	RO	0x0004 (4 <sub>dec</sub> )

**Index F008: Code word**

Index (hex)	Name	Meaning	Data type	Flags	Default
F008:0	Code word	reserved	UINT32	RW	0x00000000 (0 <sub>dec</sub> )

**Index F010: Module list**

Index (hex)	Name	Meaning	Data type	Flags	Default
F010:0	Module list	Maximum subindex	UINT8	RW	0x04 (4 <sub>dec</sub> )
F010:01	SubIndex 001		UINT32	RW	0x0000014A (330 <sub>dec</sub> )
F010:02	SubIndex 002		UINT32	RW	0x0000014A (330 <sub>dec</sub> )
F010:03	SubIndex 003		UINT32	RW	0x0000014A (330 <sub>dec</sub> )
F010:04	SubIndex 004		UINT32	RW	0x0000014A (330 <sub>dec</sub> )

**Index F080: Channel Enable**

Index (hex)	Name	Meaning	Data type	Flags	Default	
F080:0	Channel Enable	Maximum subindex	UINT8	RO	0x04 (4 <sub>dec</sub> )	
F080:01	SubIndex 001	0	Channel 1 disabled	BOOLEAN	RW	0x01 (1 <sub>dec</sub> )
		1	Channel 1 enabled			
F080:02	SubIndex 002	0	Channel 2 disabled	BOOLEAN	RW	0x01 (1 <sub>dec</sub> )
		1	Channel 2 enabled			
F080:03	SubIndex 003	0	Channel 3 disabled	BOOLEAN	RW	0x01 (1 <sub>dec</sub> )
		1	Channel 3 enabled			
F080:04	SubIndex 004	0	Channel 4 disabled	BOOLEAN	RW	0x01 (1 <sub>dec</sub> )
		1	Channel 5 enabled			

(from hardware version 01 deactivated channels are not measured, and the green LED R for these channels goes out)

## 7.8 Restoring the delivery state

To restore the delivery state for backup objects in ELxxxx terminals / EPxxxx- and EPPxxxx boxes, the CoE object *Restore default parameters, SubIndex 001* can be selected in the TwinCAT System Manager (Config mode).

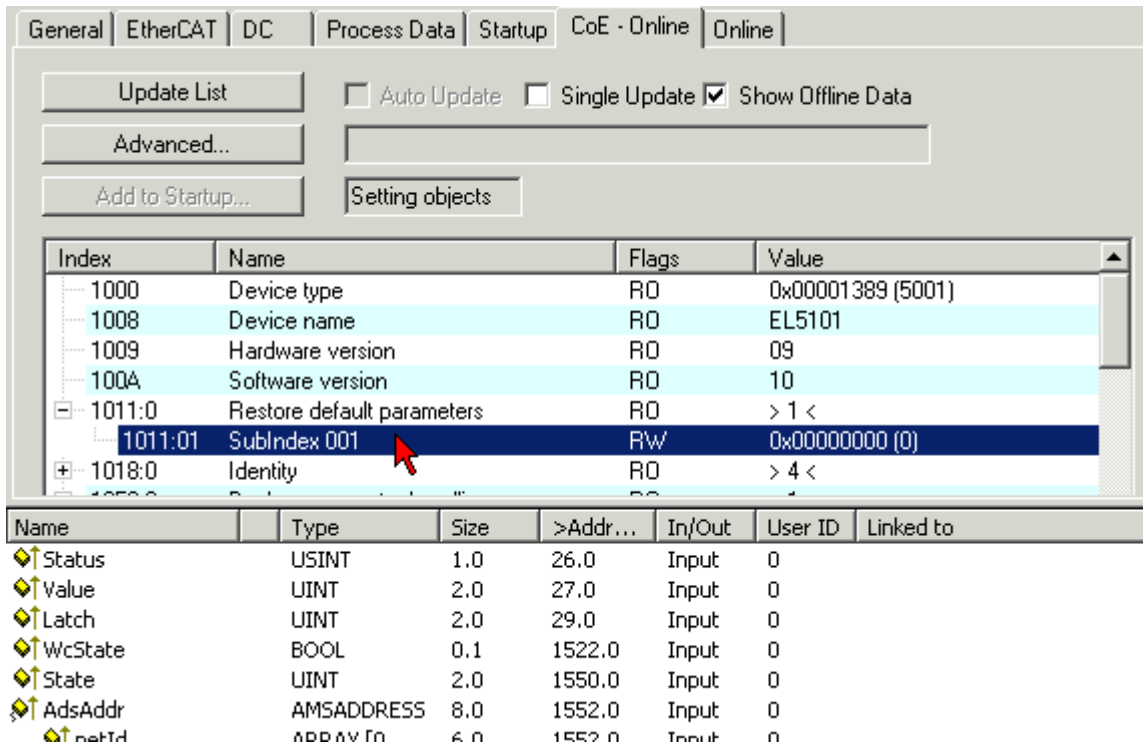

Fig. 24: Selecting the Restore default parameters PDO

Double-click on *SubIndex 001* to enter the Set Value dialog. Enter the value **1684107116** in field *Dec* or the value **0x64616F6C** in field *Hex* and confirm with OK.

All backup objects are reset to the delivery state.

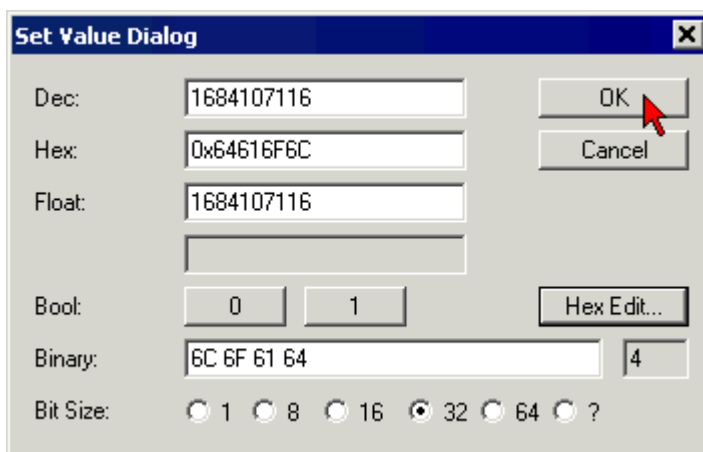

Fig. 25: Entering a restore value in the Set Value dialog

### Alternative restore value

In some older terminals / boxes the backup objects can be switched with an alternative restore value:

Decimal value: 1819238756

Hexadecimal value: 0x6C6F6164

An incorrect entry for the restore value has no effect.



## 7.9 Decommissioning

### WARNING

#### **Risk of electric shock!**

Bring the bus system into a safe, de-energized state before starting disassembly of the devices!

#### **Disposal**

In order to dispose of the device, it must be removed.

In accordance with the WEEE Directive 2012/19/EU, Beckhoff takes back old devices and accessories in Germany for proper disposal. Transport costs will be borne by the sender.

Return the old devices with the note "for disposal" to:

Beckhoff Automation GmbH & Co. KG  
Service Department  
Stahlstraße 31  
D-33415 Verl

## 8 Appendix

### 8.1 General operating conditions

#### Protection degrees (IP-Code)

The standard IEC 60529 (DIN EN 60529) defines the degrees of protection in different classes.

1. Number: dust protection and touch guard	Definition
0	Non-protected
1	Protected against access to hazardous parts with the back of a hand. Protected against solid foreign objects of Ø 50 mm
2	Protected against access to hazardous parts with a finger. Protected against solid foreign objects of Ø 12.5 mm.
3	Protected against access to hazardous parts with a tool. Protected against solid foreign objects Ø 2.5 mm.
4	Protected against access to hazardous parts with a wire. Protected against solid foreign objects Ø 1 mm.
5	Protected against access to hazardous parts with a wire. Dust-protected. Intrusion of dust is not totally prevented, but dust shall not penetrate in a quantity to interfere with satisfactory operation of the device or to impair safety.
6	Protected against access to hazardous parts with a wire. Dust-tight. No intrusion of dust.

2. Number: water* protection	Definition
0	Non-protected
1	Protected against water drops
2	Protected against water drops when enclosure tilted up to 15°.
3	Protected against spraying water. Water sprayed at an angle up to 60° on either side of the vertical shall have no harmful effects.
4	Protected against splashing water. Water splashed against the disclosure from any direction shall have no harmful effects
5	Protected against water jets
6	Protected against powerful water jets
7	Protected against the effects of temporary immersion in water. Intrusion of water in quantities causing harmful effects shall not be possible when the enclosure is temporarily immersed in water for 30 min. in 1 m depth.

\*) These protection classes define only protection against water!

#### Chemical Resistance

The Resistance relates to the Housing of the IP 67 modules and the used metal parts. In the table below you will find some typical resistance.

Character	Resistance
Steam	at temperatures >100°C: not resistant
Sodium base liquor (ph-Value > 12)	at room temperature: resistant > 40°C: not resistant
Acetic acid	not resistant
Argon (technical clean)	resistant

#### Key

- resistant: Lifetime several months
- non inherently resistant: Lifetime several weeks
- not resistant: Lifetime several hours resp. early decomposition

## 8.2 Accessories

### Mounting

Ordering information	Description
ZS5300-0011	Mounting rail

### Cables and connectors

A complete overview of pre-assembled cables for fieldbus components can be found [here](#).

Ordering information	Description	Link
ZK1090-3xxx-xxxx	EtherCAT cable M8, green	<a href="#">Website</a>
ZK1093-3xxx-xxxx	EtherCAT cable M8, yellow	<a href="#">Website</a>
ZK2000-7xxx-0xxx	Sensor cable M12, 4-pin + shield	<a href="#">Website</a>
ZK2020-3xxx-xxxx	Power cable M8, 4-pin	<a href="#">Website</a>
ZS2000-3712	Sensor plug M12 with thermocouple compensation	<a href="#">Website</a>

### Labeling material, protective caps

Ordering information	Description
ZS5000-0010	Protective cap for M8 sockets, IP67 (50 pieces)
ZS5000-0020	Protective cap for M12 sockets, IP67 (50 pcs.)
ZS5100-0000	Inscription labels, unprinted, 4 strips of 10
ZS5000-xxxx	Printed inscription labels on enquiry

### Tools

Ordering information	Description
ZB8801-0000	Torque wrench for plugs, 0.4...1.0 Nm
ZB8801-0001	Torque cable key for M8 / wrench size 9 for ZB8801-0000
ZB8801-0002	Torque cable key for M12 / wrench size 13 for ZB8801-0000
ZB8801-0003	Torque cable key for M12 field assembly / wrench size 18 for ZB8801-0000



#### Further accessories

Further accessories can be found in the price list for fieldbus components from Beckhoff and online at <https://www.beckhoff.com>.

## 8.3 Version identification of EtherCAT devices

### Designation

A Beckhoff EtherCAT device has a 14-digit designation, made up of

- family key
- type
- version
- revision

Example	Family	Type	Version	Revision
EL3314-0000-0016	EL terminal (12 mm, non-pluggable connection level)	3314 (4-channel thermocouple terminal)	0000 (basic type)	0016
ES3602-0010-0017	ES terminal (12 mm, pluggable connection level)	3602 (2-channel voltage measurement)	0010 (high-precision version)	0017
CU2008-0000-0000	CU device	2008 (8-port fast ethernet switch)	0000 (basic type)	0000

### Notes

- The elements mentioned above result in the **technical designation**. EL3314-0000-0016 is used in the example below.
- EL3314-0000 is the order identifier, in the case of "-0000" usually abbreviated to EL3314. "-0016" is the EtherCAT revision.
- The **order identifier** is made up of
  - family key (EL, EP, CU, ES, KL, CX, etc.)
  - type (3314)
  - version (-0000)
- The **revision** -0016 shows the technical progress, such as the extension of features with regard to the EtherCAT communication, and is managed by Beckhoff.  
In principle, a device with a higher revision can replace a device with a lower revision, unless specified otherwise, e.g. in the documentation.  
Associated and synonymous with each revision there is usually a description (ESI, EtherCAT Slave Information) in the form of an XML file, which is available for download from the Beckhoff web site.  
From 2014/01 the revision is shown on the outside of the IP20 terminals, see Fig. "EL5021 EL terminal, standard IP20 IO device with batch number and revision ID (since 2014/01)".
- The type, version and revision are read as decimal numbers, even if they are technically saved in hexadecimal.

### Identification number

Beckhoff EtherCAT devices from the different lines have different kinds of identification numbers:

#### Production lot/batch number/serial number/date code/D number

The serial number for Beckhoff IO devices is usually the 8-digit number printed on the device or on a sticker. The serial number indicates the configuration in delivery state and therefore refers to a whole production batch, without distinguishing the individual modules of a batch.

Structure of the serial number: **KK YY FF HH**

KK - week of production (CW, calendar week)

YY - year of production

FF - firmware version

HH - hardware version

Example with

Ser. no.: 12063A02: 12 - production week 12 06 - production year 2006 3A - firmware version 3A 02 - hardware version 02

Exceptions can occur in the **IP67 area**, where the following syntax can be used (see respective device documentation):

Syntax: D ww yy x y z u

D - prefix designation

ww - calendar week

yy - year

x - firmware version of the bus PCB

y - hardware version of the bus PCB

z - firmware version of the I/O PCB

u - hardware version of the I/O PCB

Example: D.22081501 calendar week 22 of the year 2008 firmware version of bus PCB: 1 hardware version of bus PCB: 5 firmware version of I/O PCB: 0 (no firmware necessary for this PCB) hardware version of I/O PCB: 1

### Unique serial number/ID, ID number

In addition, in some series each individual module has its own unique serial number.

See also the further documentation in the area

- IP67: [EtherCAT Box](#)
- Safety: [TwinSafe](#)
- Terminals with factory calibration certificate and other measuring terminals

### Examples of markings



Fig. 26: EL5021 EL terminal, standard IP20 IO device with serial/ batch number and revision ID (since 2014/01)



Fig. 27: EK1100 EtherCAT coupler, standard IP20 IO device with serial/ batch number



Fig. 28: CU2016 switch with serial/ batch number



Fig. 29: EL3202-0020 with serial/ batch number 26131006 and unique ID-number 204418



Fig. 30: EP1258-00001 IP67 EtherCAT Box with batch number/ date code 22090101 and unique serial number 158102

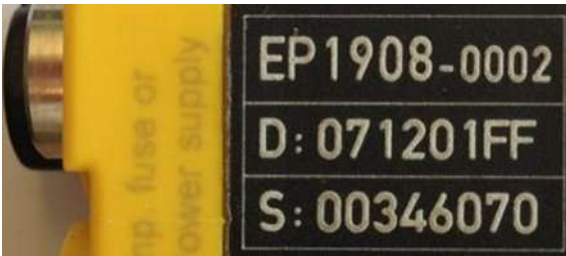

Fig. 31: EP1908-0002 IP67 EtherCAT Safety Box with batch number/ date code 071201FF and unique serial number 00346070



Fig. 32: EL2904 IP20 safety terminal with batch number/ date code 50110302 and unique serial number 00331701



Fig. 33: ELM3604-0002 terminal with unique ID number (QR code) 100001051 and serial/ batch number 44160201

### 8.3.1 Beckhoff Identification Code (BIC)

The Beckhoff Identification Code (BIC) is increasingly being applied to Beckhoff products to uniquely identify the product. The BIC is represented as a Data Matrix Code (DMC, code scheme ECC200), the content is based on the ANSI standard MH10.8.2-2016.



Fig. 34: BIC as data matrix code (DMC, code scheme ECC200)

The BIC will be introduced step by step across all product groups.

Depending on the product, it can be found in the following places:

- on the packaging unit
- directly on the product (if space suffices)
- on the packaging unit and the product

The BIC is machine-readable and contains information that can also be used by the customer for handling and product management.

Each piece of information can be uniquely identified using the so-called data identifier (ANSI MH10.8.2-2016). The data identifier is followed by a character string. Both together have a maximum length according to the table below. If the information is shorter, spaces are added to it. The data under positions 1 to 4 are always available.

The following information is contained:



Item no.	Type of information	Explanation	Data identifier	Number of digits incl. data identifier	Example
1	Beckhoff order number	<b>Beckhoff order number</b>	1P	8	<b>1P</b> 072222
2	Beckhoff Traceability Number (BTN)	<b>Unique serial number, see note below</b>	S	12	<b>S</b> BTNk4p562d7
3	Article description	<b>Beckhoff article description, e.g. EL1008</b>	1K	32	<b>1K</b> EL1809
4	Quantity	<b>Quantity in packaging unit, e.g. 1, 10, etc.</b>	Q	6	<b>Q</b> 1
5	Batch number	Optional: Year and week of production	2P	14	<b>2P</b> 401503180016
6	ID/serial number	Optional: Present-day serial number system, e.g. with safety products or calibrated terminals	51S	12	<b>51S</b> 678294104
7	Variant number	Optional: Product variant number on the basis of standard products	30P	32	<b>30P</b> F971, 2*K183
...					

Further types of information and data identifiers are used by Beckhoff and serve internal processes.

**Structure of the BIC**

Example of composite information from item 1 to 4 and 6. The data identifiers are marked in red for better display:

**BTN**

An important component of the BIC is the Beckhoff Traceability Number (BTN, item no. 2). The BTN is a unique serial number consisting of eight characters that will replace all other serial number systems at Beckhoff in the long term (e.g. batch designations on IO components, previous serial number range for safety products, etc.). The BTN will also be introduced step by step, so it may happen that the BTN is not yet coded in the BIC.

<b>NOTE</b>
This information has been carefully prepared. However, the procedure described is constantly being further developed. We reserve the right to revise and change procedures and documentation at any time and without prior notice. No claims for changes can be made from the information, illustrations and descriptions in this information.

## 8.4 Support and Service

Beckhoff and their partners around the world offer comprehensive support and service, making available fast and competent assistance with all questions related to Beckhoff products and system solutions.

### Beckhoff's branch offices and representatives

Please contact your Beckhoff branch office or representative for local support and service on Beckhoff products!

The addresses of Beckhoff's branch offices and representatives round the world can be found on her internet pages: <https://www.beckhoff.com>

You will also find further documentation for Beckhoff components there.

### Beckhoff Support

Support offers you comprehensive technical assistance, helping you not only with the application of individual Beckhoff products, but also with other, wide-ranging services:

- support
- design, programming and commissioning of complex automation systems
- and extensive training program for Beckhoff system components

Hotline: +49 5246 963 157  
Fax: +49 5246 963 9157  
e-mail: [support@beckhoff.com](mailto:support@beckhoff.com)

### Beckhoff Service

The Beckhoff Service Center supports you in all matters of after-sales service:

- on-site service
- repair service
- spare parts service
- hotline service

Hotline: +49 5246 963 460  
Fax: +49 5246 963 479  
e-mail: [service@beckhoff.com](mailto:service@beckhoff.com)

### Beckhoff Headquarters

Beckhoff Automation GmbH & Co. KG

Huelshorstweg 20  
33415 Verl  
Germany

Phone: +49 5246 963 0  
Fax: +49 5246 963 198  
e-mail: [info@beckhoff.com](mailto:info@beckhoff.com)  
web: <https://www.beckhoff.com>



Beckhoff Automation GmbH & Co. KG  
Hülshorstweg 20  
33415 Verl  
Germany  
Phone: +49 5246 9630  
[info@beckhoff.com](mailto:info@beckhoff.com)  
[www.beckhoff.com](http://www.beckhoff.com)