

# **Electromechanical Actuator**

## **Design Guide**



**TracMaster™**

**Electromechanical  
Linear Actuators  
& Controls**

**Duff-Norton®**



Since 1883, Duff-Norton has manufactured quality industrial lifting, positioning and material handling equipment. Today, Duff-Norton continues this tradition through its dedication to the ISO 9001 standard of excellence.

*Duff-Norton Manufactures the Following Products:*

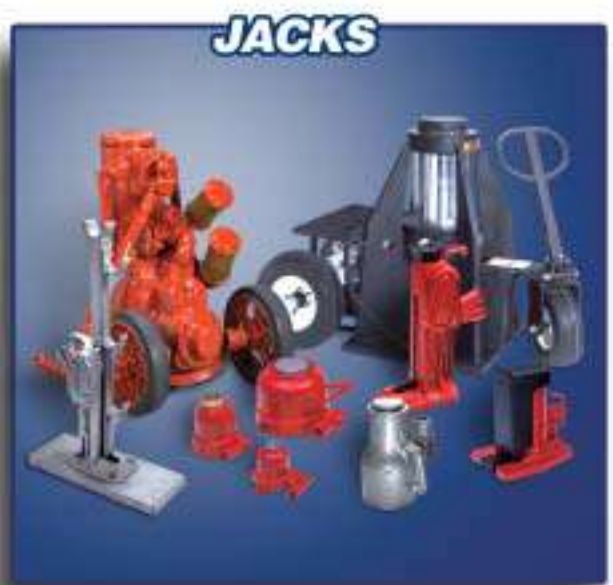

# Contents

Introduction . . . . .	4
Installation Information . . . . .	5
Applications . . . . .	6
Application Analysis Form . . . . .	8
Quick Reference Guide . . . . .	9
<i>Technical Information</i>	
100 Pound Capacity	
Series TMD100 . . . . .	10
250 Pound Capacity	
Series TMD250 . . . . .	12
Series TMA250-MP . . . . .	14
Series TMAL250-MP . . . . .	16
Series TMD250-MP. . . . .	18
Series TMDL250-MP . . . . .	20
500 Pound Capacity	
Series TMA500-MP . . . . .	22
Series TMAL500-MP . . . . .	24
Series TMD500-MP . . . . .	26
Series TMDL500-MP. . . . .	28
Series TA500 . . . . .	30
1000 Pound Capacity	
Series TA1000 . . . . .	32
Series TMAL1000-HD . . . . .	34
Series TMDL1000-HD . . . . .	36
1500 Pound Capacity	
Series TMAL1500-SP . . . . .	38
Series TMD1500-SP . . . . .	40
Series TMDL1500-SP . . . . .	42
2000 Pound Capacity	
Series TMAL2000-SP . . . . .	44
Modular Actuator . . . . .	46
Power Supplies . . . . .	52
Controls . . . . .	53
Digital Position Indicator . . . . .	62
Glossary . . . . .	63
Frequently Asked Questions . . . . .	64
Terms & Conditions . . . . .	66

### *Packaged Solutions, Countless Applications*

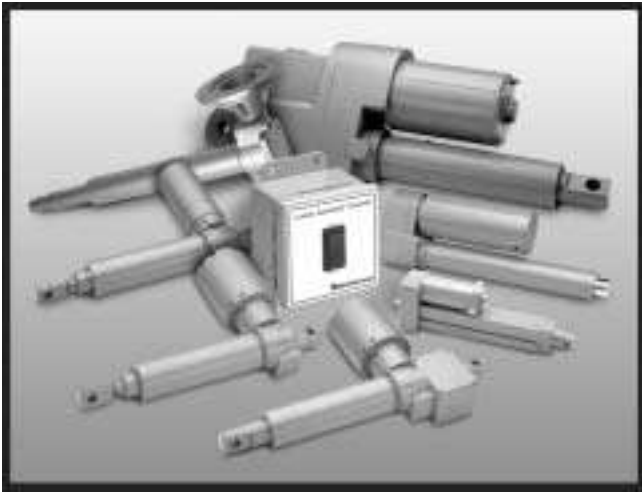

Duff-Norton electromechanical actuators are the best packaged solution for your linear actuation needs. With capacities ranging from 100 to 2,000 pounds, no one offers a greater selection of both AC and DC models. This extensive line of models is designed to meet the requirements of the most challenging applications. Benefiting from the latest in advanced design techniques, manufacturing methods, and over three decades of electromechanical product

experience, Duff-Norton packaged electromechanical actuators last longer and run smoother with little maintenance and no headaches. If you have a linear actuation application, Duff-Norton has the packaged solution for you.

### *Duff-Norton Customer Service Programs*

Duff-Norton gives you the benefit of over a century of customer service. From stocking distributor programs, to expert application engineering, Duff-Norton is committed to providing you with the right solution every time. Our staff works hard to make sure you always get the product you need, when you need it.

The answer to all of your questions are always just a phone call away. Our Sales Engineers are ready to answer any question you may have about price, volume orders, availability or delivery. Additionally, there is always a District Sales Manager near you, ready to discuss your application and any special requirements you may have. Duff-Norton's Application Engineers will apply their years of experience to determine the right product to fit your needs, or to design a complete system to fulfill all of your requirements. This saves you time and money in the design, specification, procurement and installation of system components.

Whether you need a packaged solution, or one that has been custom designed to fit your specifications, Duff-Norton offers the expertise that comes from working closely with our worldwide customers. Combined with this history is a commitment to technology. We strive to constantly improve our manufacturing methods and stay ahead of industry trends in both our products and our philosophies. This comprehensive approach to customer service makes Duff-Norton actuators an exceptional value; we are always aware that we must provide the right solution every time.

Next time you have a linear motion need, call Duff-Norton first. Our Customer Service staff will take it from there!

## Installation and Loading

Duff-Norton electromechanical actuators can be used in tension, compression, or combination tension/compression applications. Examples of tension and compression are shown on right.

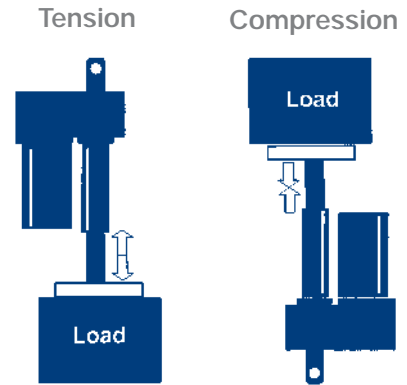

It is important to mount the actuator so that side loading and eccentric loading are avoided. To optimize the performance and life of the actuator, it should be mounted so that the load is applied along the longitudinal axis of the translating tube. Examples of proper and improper loading arrangements are shown below.

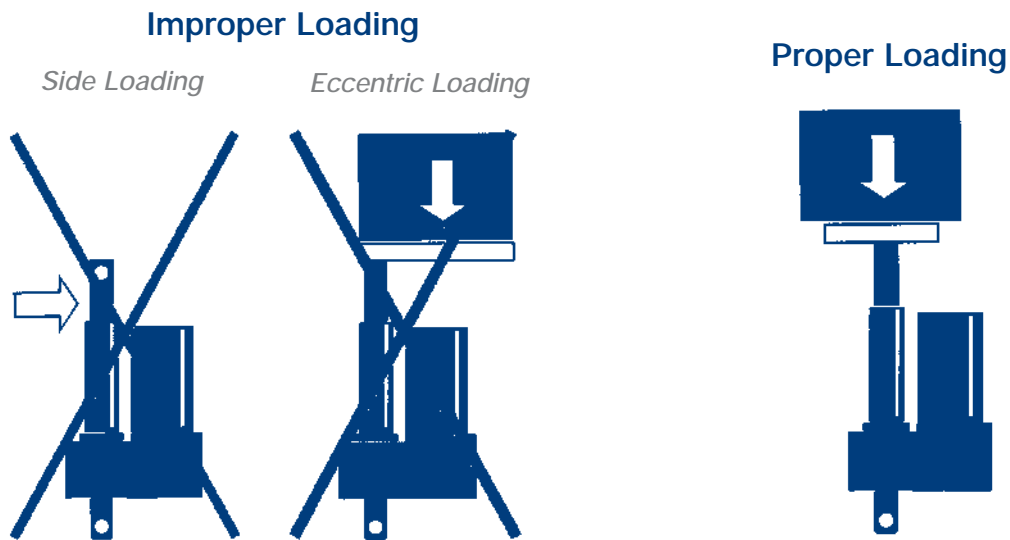

Once the optimal mounting arrangement has been determined, Duff-Norton electromechanical actuators are mounted by simply slipping a solid pin through the translating tube clevis and rear housing clevis. The pins must be parallel to each other in order to avoid binding. The actuator restraining brackets and related hardware must be able to withstand the torque generated by the actuator as it extends and retracts. Restraining torque varies with actuator family.





# Applications

## Tilt/Pivot

Duff-Norton Electro-mechanical Actuators can be used to tilt objects, fixed at one end, up to 180° from their starting positions. The extension and retraction of the actuator causes the object to pivot about its stationary end.

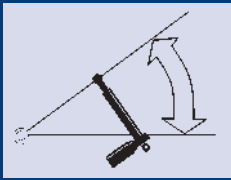

## Portable Roadside Lighting

**Problem:** Construction and emergency crews need portable lighting for work at night. Lighting that is compact for travel and easily erected on location was difficult to find.

**Solution:** A Duff-Norton electromechanical actuator mounted to the skeleton of the lighting system allows the lights to be drawn flush against the vehicle, then fully

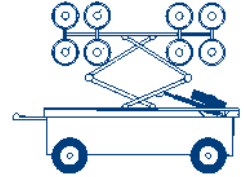

## Lift/Lower

Duff-Norton Electro-mechanical Actuators can handle any lifting and lowering application up to 2000 lbs (910 kgs). As the translating tube of the actuator extends and retracts, the object that the actuator is attached to is raised and lowered at a constant speed.

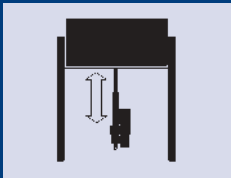

## Drill Press Table

**Problem:** When work pieces of different sizes require manual machining, it is necessary to adjust the height of the drill press table. Adjusting the height of the table manually is both time consuming and fatiguing.

**Solution:** A Duff-Norton electromechanical actuator mounted under the table allows the operator to change the height of the table as often as needed using either hand or foot controls.



## Position

When an application requires periodic adjustment to the position of an object or objects, Duff-Norton Electromechanical Actuators provide the solution. The motion of the actuator allows the operator to position an object by simply pushing a button.

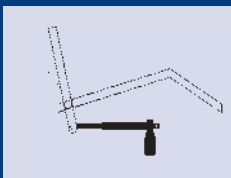

## Dental Chair

**Problem:** Dental chairs must be highly adjustable to position patients for different procedures. The movement of the chair must be smooth and reliable.

**Solution:** Duff-Norton electromechanical actuators are built into the frame of the chair. They are operated independently to allow precise positioning of the patient.

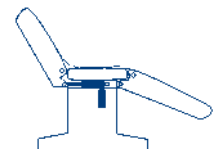

# Applications

## Roll/Slide

When it is necessary to roll or slide an object or a mechanical assembly into position, a Duff-Norton electromechanical actuator is the answer. The movement of the actuator causes the clamping, rolling or sliding of the desired object.

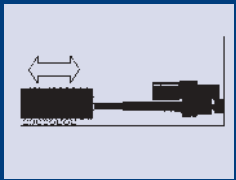

## Drum/Barrel Lifter

**Problem:** Hazardous material sealed in drums must be handled and processed for disposal. It is desirable to minimize human involvement in the process.

**Solution:** Two Duff-Norton electromechanical actuators are used in each assembly. One operates a set of ratcheting clamps that securely grasp the drum. The other actuator lifts the drum so it can be moved to its next location.



## Open/Close

A Duff-Norton electromechanical actuator mounted on a door, gate, or valve allows opening and closing operations on either a timed, or on-demand basis. As the actuator retracts, the gate is opened at a steady rate; the extension of the actuator returns the gate to a closed position.

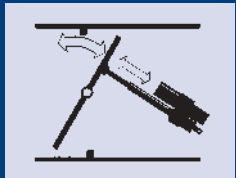

## Industrial Oven

**Problem:** Industrial oven doors can be very large and must often be opened and closed on a timed basis to allow for the steady flow of material in and out.

**Solution:** A Duff-Norton electromechanical actuator is connected to the oven door and operated by an electronic control system. The actuator opens and closes the door to allow materials to enter and exit when prompted by the control system.

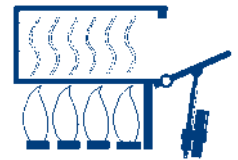

## Tension

Duff-Norton Electro-mechanical Actuators offer a perfect solution for applications in which tension on a conveyor or webb must be maintained and adjusted. An actuator mounted on a frame or roller extends and retracts to control the tension in the system.

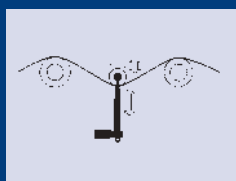

## Conveyor System

**Problem:** The tension in conveyor belts must frequently be adjusted to allow for crates of different sizes and to take up slack in the system that develops with use.

**Solution:** A Duff-Norton electromechanical actuator is mounted to a roll at one end of the conveyor system. At the push of a button the actuator adjusts the position of the roll, controlling the tension in the entire system. Actuators can also be used to reposition conveyor systems.



### ⚠ WARNING

Improper use can result in personal injury.

To avoid injury:

- Do not use actuators to lift, support, or transport people or loads over people, without written approval from Duff-Norton.
- Read all product warnings and operating instructions.

**Electromechanical Actuator  
Application Analysis Form**

*Duff-Norton engineers will be pleased to make recommendations for your specific requirements. Complete this form and mail or fax it to Duff-Norton Company. There is no obligation for this service. Use a separate sheet to sketch your application, or send us your design drawings in complete confidence.*

Customer: \_\_\_\_\_

Address: \_\_\_\_\_

Phone Number: \_\_\_\_\_ Fax Number: \_\_\_\_\_

Contact: \_\_\_\_\_

Email Address: \_\_\_\_\_

1. How many pounds (kgs) do you need to move, or how great is the force you need to move (in pounds or newtons)? \_\_\_\_\_

2. How many inches (mm) do you need to move the load? \_\_\_\_\_

3. What is your available power source?

 115 VAC, 60Hz 220 VAC, 50Hz 12 VDC 24VDC Other (Please Specify) \_\_\_\_\_4. Do you need:  Clutch  Limit Switch

5. How fast (inches/min. or mm/min.) do you want the actuator to extend or retract? \_\_\_\_\_

6. How many cycles per hour do you need the actuator to perform? \_\_\_\_\_

7. Do you require position feedback?  Yes  No8. All AC actuators require a capacitor for operation. Do you want Duff-Norton to supply a capacitor?  
(NOTE: for 1500 pound and above capacity models, a capacitor is automatically supplied) Yes, please supply capacitor No, I will purchase a capacitor separately that meets the specifications outlined by Duff-Norton.9. Do you require an electric control to operate the actuator?  Yes  No

NOTE: Capacitors (if required) are included in the control box.

10. Do you have any special requirements such as weather resistant treatment, non standard lifting stroke, explosion proof, special end or mounting? \_\_\_\_\_

11. How many actuators are required? \_\_\_\_\_

If you have any questions or are in need of assistance please call our Application Engineers at 800-477-5002

**▲ WARNING**Improper use can result in personal injury.  
To avoid injury:

- Do not use actuators to lift, support, or transport people or loads over people, without written approval from Duff-Norton.
- Read all product warnings and operating instructions.

Please mail or fax completed sheet to:



P.O. Box 7010 • Charlotte, NC 28241-7010

FAX 704-588-1994

www.duffnorton.com



# Quick Reference Guide

TracMaster™ Series	Capacity (lbs.)	Model	Stroke Length (inches)	Input Voltage	Clutch	Limit Switch	Position Feedback	Machine or Ball Screw	Duty Cycle (In/Hr)	Lifting Speed (In/Min)
TMD100	100	TMD01-1406	2,4,6,8,10,12	12 VDC				M	585	40
	100	TMD01-1906	2,4,6,8,10,12	12 VDC		*		M	450	40
	100	TMD01-2406	2,4,6,8,10,12	24 VDC				M	900	60
	100	TMD01-2906	2,4,6,8,10,12	24 VDC		*		M	870	60
TMD250	250	TMD02-1406	2,4,6,8,10,12	12 VDC				M	375	24
	250	TMD02-1906	2,4,6,8,10,12	12 VDC		*		M	330	24
	250	TMD02-2406	2,4,6,8,10,12	24 VDC				M	630	45
	250	TMD02-2906	2,4,6,8,10,12	24 VDC		*		M	495	45
TMA250-MP	250	SPB3405	3,6,12,18	115 VAC (60 Hz)	*			M	575	40
	250	SPB4405	3,6,12,18	220 VAC (50 Hz)	*			M	435	34
	250	HSPB3405	3,6,12,18	115 VAC (60 Hz)	*			M	500	86
TMD250-MP	250	MPD3405	3,6,12,18	12 VDC	*			M	1250	60
	250	MPD3404	3,6,12,18	24 VDC	*			M	1200	66
	250	HMPD3405	3,6,12,18	12 VDC	*			M	1000	143
TMAL250-MP	250	MPB3905	3,6,12,18	115 VAC (60 Hz)		*		M	575	40
	250	MPB4905	3,6,12,18	220 VAC (50 Hz)		*		M	435	34
	250	HMPB3905	3,6,12,18	115 VAC (60 Hz)		*		M	500	86
	250	PMPB3905	3,6,12,18	115 VAC (60 Hz)		*	*	M	575	40
	250	PMPB4905	3,6,12,18	220 VAC (50 Hz)		*	*	M	435	34
	250	PHMPB3905	3,6,12,18	115 VAC (60 Hz)		*	*	M	500	86
TMDL250-MP	250	MPD3905	3,6,12,18	12 VDC		*		M	1250	60
	250	MPD3904	3,6,12,18	24 VDC		*		M	1200	66
	250	HMPD3905	3,6,12,18	12 VDC		*		M	1000	143
TMA500-MP	500	SPB6405	3,6,12,18	115VAC (60 Hz)	*			M	500	35
	500	SPB7405	3,6,12,18	220 VAC (50 Hz)	*			M	435	32
	500	HSPB6405	3,6,12,18	115 VAC (60 Hz)	*			M	500	79
TMD500-MP	500	MPD6405	3,6,12,18	12 VDC	*			M	450	44
	500	MPD6404	3,6,12,18	24 VDC	*			M	500	50
TMAL500-MP	500	MPB6905	3,6,12,18	115 VAC (60 Hz)		*		M	500	35
	500	MPB7905	3,6,12,18	220 VAC (50 Hz)		*		M	435	32
	500	HMPB6905	3,6,12,18	115 VAC (60 Hz)		*		M	500	79
	500	PMPB6905	3,6,12,18	115 VAC (60 Hz)		*	*	M	500	35
	500	PMPB7905	3,6,12,18	220 VAC (50 Hz)		*	*	M	435	32
	500	PHMPB6905	3,6,12,18	115 VAC (60 Hz)		*	*	M	500	79
TMDL500-MP	500	MPD6905	3,6,12,18	12 VDC		*		M	450	44
	500	MPD6904	3,6,12,18	24 VDC		*		M	500	50
TA500	500	TAL05-1A10-	4,8,12	115 VAC, (60 Hz)		*		M	17.5%	52
	500	TAP05-1A10-	4,8,12	115 VAC, (60 Hz)		*	*	M	17.5%	52
	500	TAL05-2A10-	4,8,12	220 VAC, (50,60 Hz)		*		M	17.0%	54 (60 Hz)
	500	TAP05-2A10-	4,8,12	220 VAC, (50,60 Hz)		*	*	M	17.0%	54 (60 Hz)
	500	TAC05-1D20-	4,8,12	12 VDC	*			M	40.0%	27
500	TAC05-2D20-	4,8,12	24 VDC	*			M	40.0%	27	
TA1000	1000	TAL10-1A20-	4,8,12	115 VAC, (60 Hz)		*		M	17.5%	26
	1000	TAP10-1A20-	4,8,12	115 VAC, (60 Hz)		*	*	M	17.5%	26
	1000	TAL10-2A20-	4,8,12	220 VAC, (50,60 Hz)		*		M	17.5%	27(60 Hz)
	1000	TAP10-2A20-	4,8,12	220 VAC, (50,60 Hz)		*	*	M	17.5%	27(60 Hz)
TMAL1000-HD	1000	SPA 3410	3,6,12,18,24	115 VAC (60 Hz)		*		B	900	53
	1000	SPA 4410	3,6,12,18,24	220 VAC (50 Hz)		*		B	1000	50
	1000	PSPA 3410	3,6,12,18,24	115 VAC (60 Hz)		*	*	B	900	53
	1000	PSPA 4410	3,6,12,18,24	220 VAC (50 Hz)		*	*	B	1000	50
TMD1500-SP	1500	SPD6415	3,6,12,18,24	12 VDC	*			M	400	26
TMAL1500-SP	1500	SPA6415	3,6,12,18,24	115 VAC (60 Hz)		*		M	500	50
	1500	SPA7415	3,6,12,18,24	220 VAC (50 Hz)		*		M	600	41
	1500	PSPA6415	3,6,12,18,24	115 VAC (60 Hz)		*	*	M	500	50
	1500	PSPA7415	3,6,12,18,24	220 VAC (50 Hz)		*	*	M	600	41
TMDL1500-SP	1500	LSPD6415	3,6,12,18,24	12 VDC		*		M	400	26
TMD2000-SP	2000	SPD6420	3,6,12,18,24	12 VDC	*			B	600	27
TMAL2000-SP	2000	SPA6420	3,6,12,18,24	115 VAC (60 Hz)		*		B	600	52
	2000	SPA7420	3,6,12,18,24	220 VAC (50 Hz)		*		B	625	41
	2000	PSPA6420	3,6,12,18,24	115 VAC (60 Hz)		*	*	B	600	52
	2000	PSPA7420	3,6,12,18,24	220 VAC (50 Hz)		*	*	B	625	41

\* Position Feedback is provided by a potentiometer

\*\* Screw Type: M = Machine / B = Ball Screw

\*\*\* Contact Duff Norton Application Engineering

† Duty Cycle ratings represent the total travel (extension and retraction) per hour with equally timed intervals between cycles



*Compact and economical. Corrosion resistant materials throughout. Timing belt drive for quiet, smooth operation. Low current draw and keyed translating tube simplify installation requirements.*

Model Number

- TMD01-1406-stroke**  
*12 VDC without Limit Switches*
- TMD01-2406-stroke**  
*24 VDC without Limit Switches*
- TMD01-1906-stroke**  
*12 VDC with Limit Switches*
- TMD01-2906-stroke**  
*24 VDC with Limit Switches*

*Note: Model number prefix for pulse generator models is PTD01.*

**Specifications**

- Capacity** . . . . . 100 lbs (45.4 Kgf, 445 N) tension or compression loads.
- Static Load** . . . . . 300 lbs (136 Kgf, 1334 N) maximum.
- Motor** . . . . . 12 VDC or 24 VDC permanent magnet type; electrically reversible by polarity reversal.
- AC Power Options** . . . . . See power supplies, part no. PS1260 and part no. 4824.
- Stroke Lengths** . . . . . 2, 4, 6, 8, 10, and 12 inch (50, 102, 152, 203, 254, and 304 mm).
- Duty Cycle** . . . . . 25% at full load and 77°F ambient
- Construction** . . . . . Aluminum housings, stainless steel translating tube.
- Mounting** . . . . . Double clevis ends. Translating tube clevis threaded 10-32UNF to accept rod end.
- Load Screw** . . . . . Acme thread.
- Limit Switches** . . . . . Independently adjustable. Includes control enclosure with relay, fuse and terminal blocks for power and switch connections. Enclosure may be mounted on actuator tube or mounted separately.
- Extend/Retract Control** . . . . . Optional. See part no. EM1010-58.
- Temperature Range** . . . . . -20°F to 120° F (-29°C to 50°C).
- Restraining Torque** . . . . . Keyed translating tube resists rotation.
- Pulse Generator** . . . . . Optional feedback device. Contact Application Engineering for specifications.

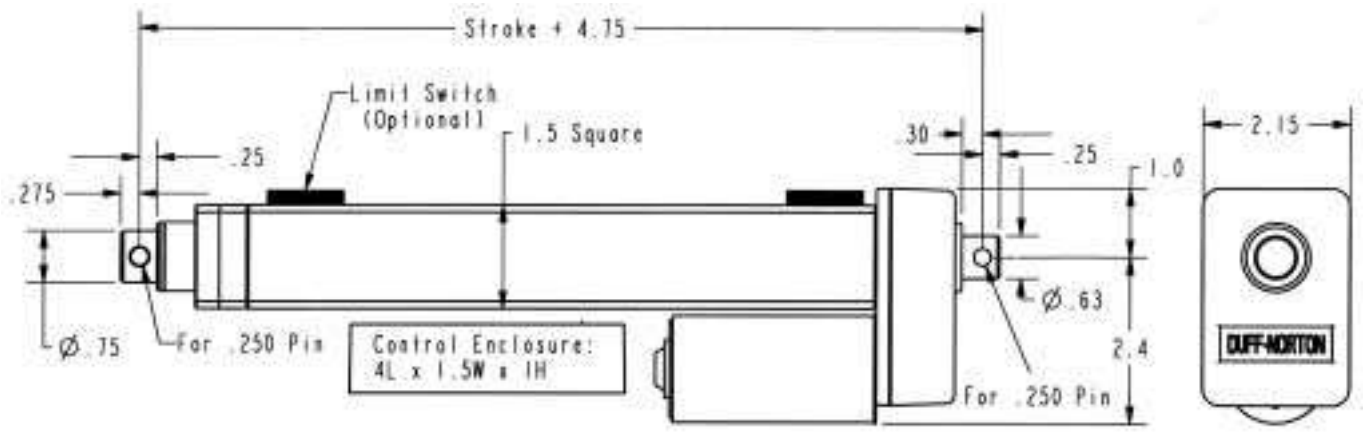

## Wiring Connections

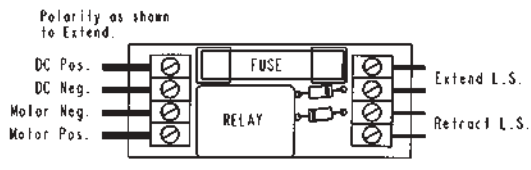

Limit Switch Models

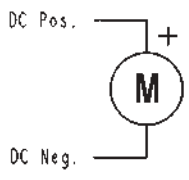

Models without Limit Switches

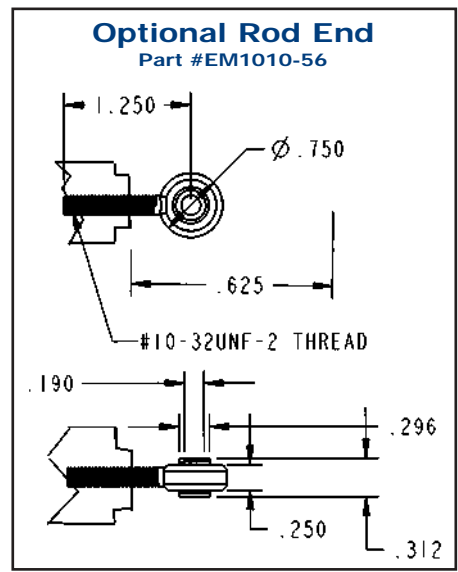

# Performance Characteristics

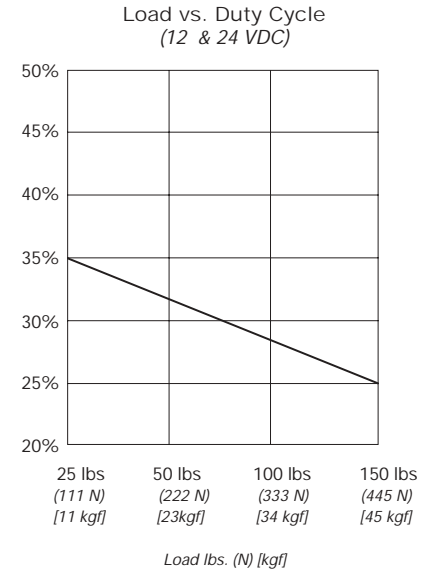
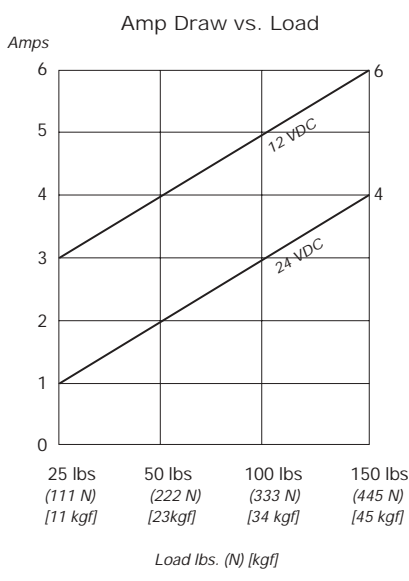
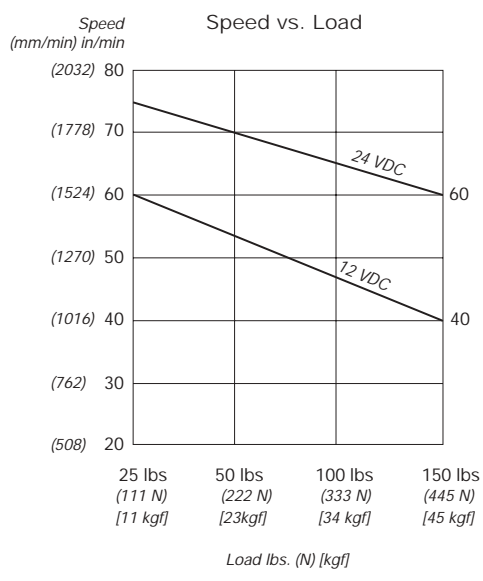

TMD100



*Compact and economical. Corrosion resistant materials throughout. Timing belt drive for quiet, smooth operation. Low current draw and keyed translating tube simplify installation requirements.*

Model Number

- TMD02-1406-stroke**  
12 VDC without Limit Switches
- TMD02-2406-stroke**  
24 VDC without Limit Switches
- TMD02-1906-stroke**  
12 VDC with Limit Switches
- TMD02-2906-stroke**  
24 VDC with Limit Switches

*Note: Model number prefix for pulse generator models is PTD02.*

**Specifications**

- Capacity** . . . . . 250 lbs (113.4 Kgf, 1112 N) tension or compression loads.
- Static Load** . . . . . 300lbs (136 Kgf, 1334 N) maximum.
- Motor** . . . . . 12 VDC or 24 VDC permanent magnet type; electrically reversible by polarity reversal.
- AC Power Options** . . . . . See power supplies, part no. PS1260 and part no. 4824.
- Stroke Lengths** . . . . . 2, 4, 6, 8, 10, and 12 inch (50, 102, 152, 203, 254, and 304 mm).
- Duty Cycle** . . . . . 25% at full load and 77°F ambient
- Construction** . . . . . Aluminum housings, stainless steel translating tube.
- Mounting** . . . . . Double clevis ends. Translating tube clevis threaded 10-32UNF to accept rod end.
- Load Screw** . . . . . Acme thread.
- Limit Switches** . . . . . Optional, customer installed. Independently adjustable. Includes control enclosure with relay, fuse and terminal blocks for power and switch connections. Enclosure may be mounted on actuator tube or mounted separately.
- Extend/Retract Control** . . . . . Optional. See part no. EM1010-58.
- Temperature Range** . . . . . -20°F to 120° F (-29°C to 50°C).
- Restraining Torque** . . . . . Keyed translating tube resists rotation.
- Pulse Generator** . . . . . Optional feedback device. Contact Application Engineering for specifications.

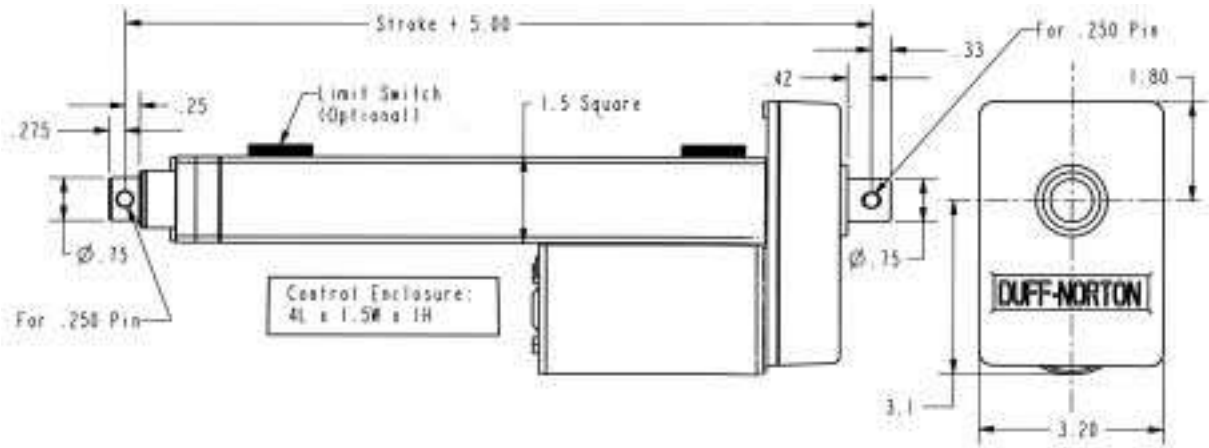

250 Pound Capacity

## Wiring Connections

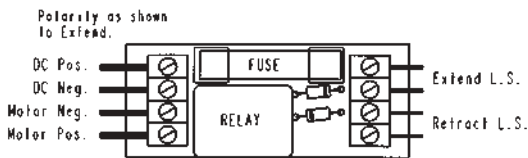

Limit Switch Models

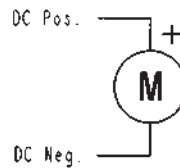

Models without Limit Switches

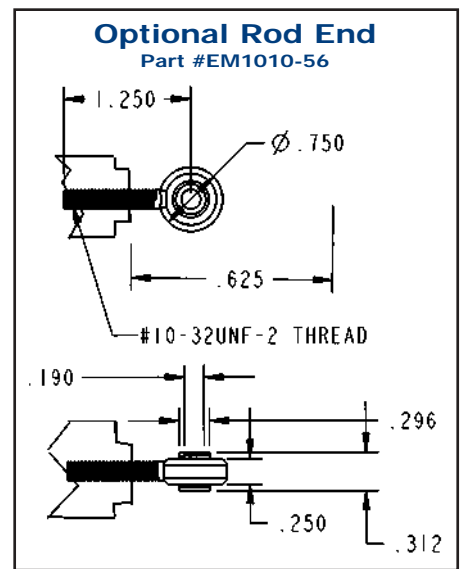

## Performance Characteristics

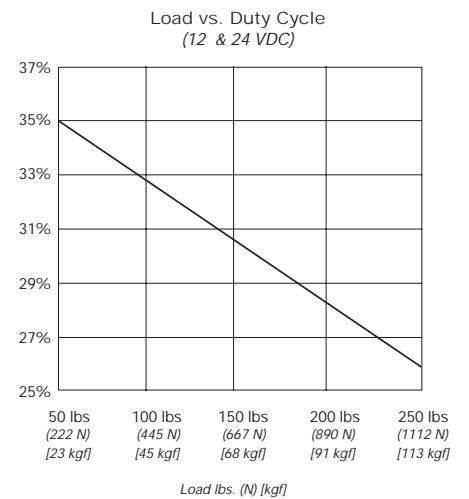
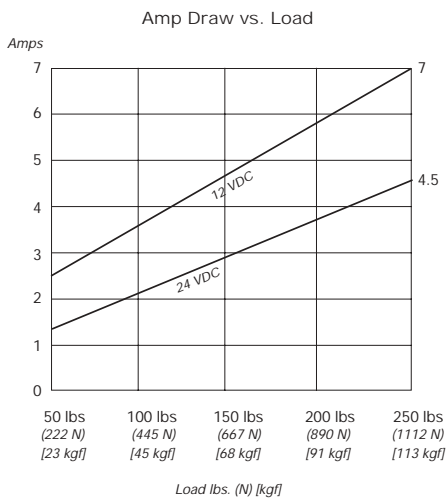
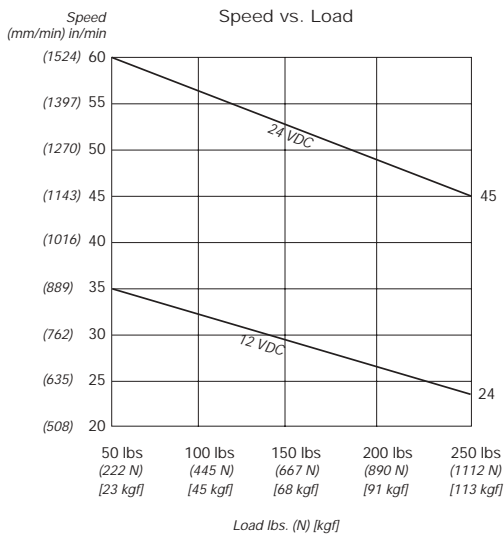





Model Number

**SPB 3405**

*115 VAC (60 Hz) with Clutch*

**SPB 4405**

*220 VAC (50 Hz) with Clutch*

**HSPB 3405**

*115 VAC (60 Hz) High Speed  
with Clutch*

**Specifications**

<b>Stroke Lengths</b>	3, 6, 12 and 18 inch 75, 150, 300, 450 mm	<b>Housing</b>	Aluminum alloy
<b>Motor Protection</b>	Automatic reset thermal overload in motor	<b>Cable Entrance</b>	1/2" NPT
<b>Temperature Range</b>	-20° F to 120° F Ambient -29° C to 50° C	<b>Clutch</b>	Load Limiting Friction Disc
<b>Drive</b>	Double Lead Screw	<b>Standard Mounting</b>	Double Clevis
		<b>Restraining Torque</b>	60 in-lbs; 6.78 N-m
		<b>Brake</b>	Bi-Directional Ball Type

115 VAC motor is an enclosed, permanent split capacitor induction type. Load/no-load speeds are approximately equal. The motor is equipped with a thermal overload device that opens and resets automatically. Standard motor requires 28-33 µfd capacitor supplied by either the customer, or Duff-Norton (SK6405-7-1) at extra cost, for loads up to 250 pounds. High speed motors require a 64-72 ufd capacitor, also available from Duff-Norton (SK6405-7-3). A capacitor box (SK6505-154A) is available on AC models only.

220 VAC motor is a totally enclosed, permanent split capacitor induction type. Load/no-load speeds are approximately equal. Equipped with thermal overload device that opens and resets automatically. Standard motor requires 10 µfd 440VAC, 60/50 Hz metalized polypropylene capacitor supplied by Duff-Norton

**CONTROLS:**

Duff-Norton Controls are also available for these actuator models as follows:

- Control Package BAC-1C for 3405 Series (std. speed)
- Control Package BAC-2C for 4405 Series (std. speed)

**NOTE:**

- Some actuator surfaces may reach 230°F during operation at or near maximum duty cycle. All ratings are nominal and based on the actuator being broken-in for approximately 2500 inches of travel.
- The thermal overload relay resets in 10 minutes

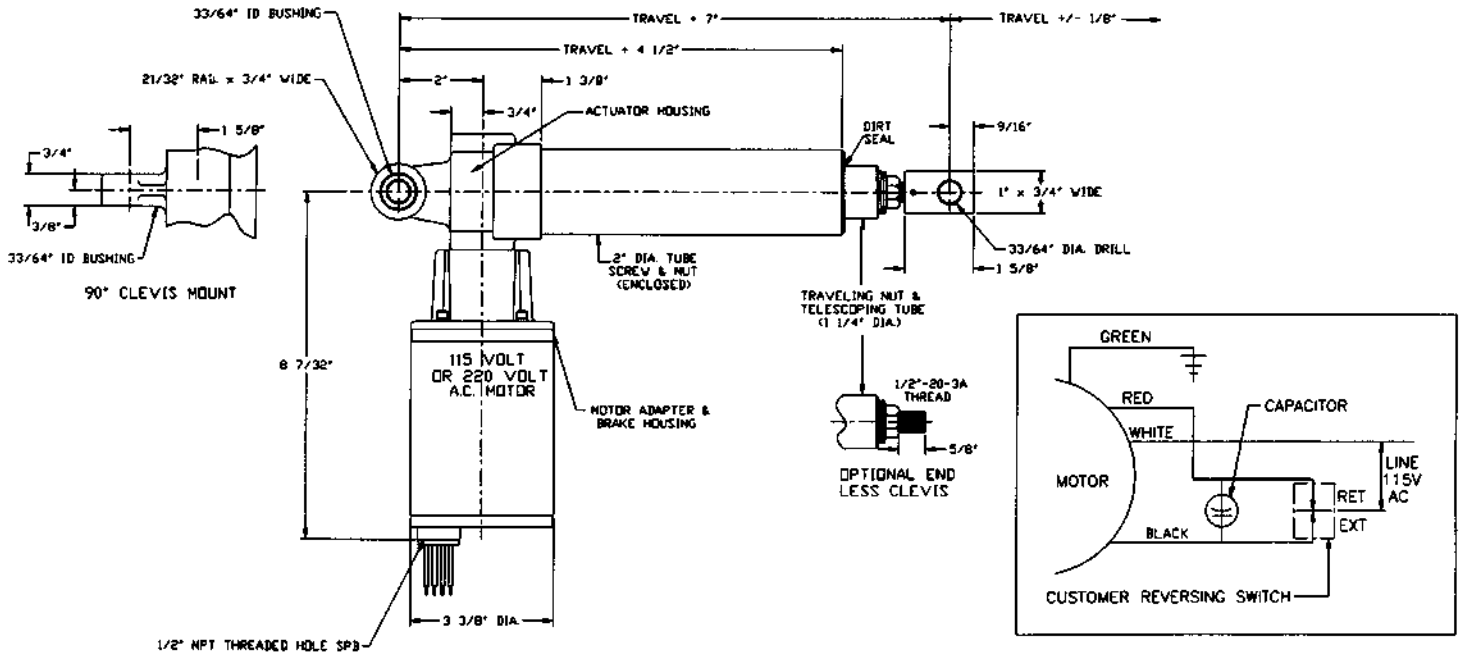

## Performance Characteristics

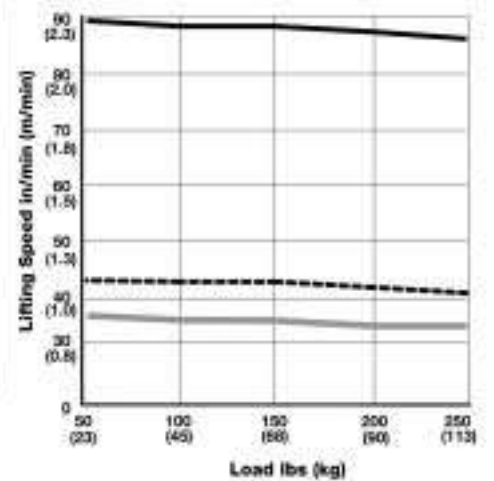
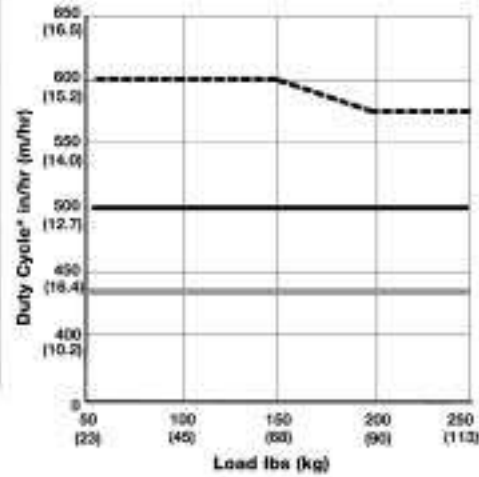
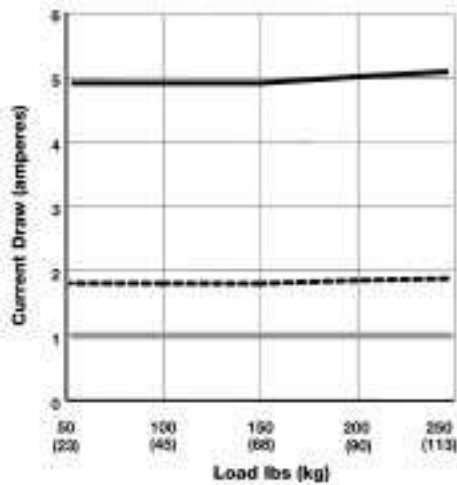

- SPB3405
- HSPB3405
- SPB4405

\* - Duty Cycle ratings represent the total travel (extension and retraction) per hour with equally timed intervals between cycles.

Model Number



**MPB 3905**

*115 VAC (60 Hz) with Limit Switches*

**MPB 4905**

*220 VAC (50 Hz) with Limit Switches*

**HMPB 3905**

*115 VAC (60 Hz) High Speed with Limit Switches*

**PMPB 3905**

*115 VAC (60 Hz) with Limit Switches and Potentiometer*

**PMPB 4905**

*220 VAC (50 Hz) with Limit Switches and Potentiometer*

**PHMPB 3905**

*115 VAC (60 Hz) High Speed with Limit Switches and Potentiometer*

**Specifications**

<b>Stroke Lengths*</b>	3, 6, 12 and 18 inch 75, 150, 300 and 450 mm	<b>Drive</b>	Double Lead Screw
<b>Motor Protection</b>	Automatic reset thermal overload in motor	<b>Housing</b>	Aluminum alloy
<b>Limit Switches</b>	Dual adjustable	<b>Cable Entrance</b>	1/2" NPT
<b>Temperature Range</b>	-20° F. to 120° F Ambient -29° C to 50° C	<b>Standard Mounting</b>	Double Clevis
		<b>Restraining Torque</b>	60 in-lbs; 6.78 N-m
		<b>Feedback</b>	Potentiometer
		<b>Brake</b>	Bi-Directional Ball Type

\* IMPORTANT - Stroke lengths are between fixed interval stops. Limit switch should be set at least .250" before stops.

**115 VAC** motor is an enclosed, permanent split capacitor induction type. Load/no-load speeds are approximately equal. The motor is equipped with a thermal overload device that opens and resets automatically. Standard motor requires 28-33 µfd capacitor supplied by either the customer, or Duff-Norton (SK6405-7-1) at extra cost, for loads up to 250 pounds. High speed motors require a 64-72 µfd capacitor, also available from Duff-Norton (SK6405-7-3). A capacitor box (SK6505-154A) is available on AC models only.

**220 VAC** motor is a totally enclosed, permanent split capacitor induction type. Load/no-load speeds are approximately equal. Equipped with thermal overload device that opens and resets automatically. Standard motor requires 10 µfd 440VAC, 60/50 Hz metalized polypropylene capacitor supplied by Duff-Norton

**CONTROLS:**

Duff-Norton Controls are also available for these actuator models as follows:

- Control Package BAC-1C for 3905 Series (std. speed)
- Control Package BAC-2C for 4905 Series (std. speed)

**NOTE:**

- Some actuator surfaces may reach 230°F during operation at or near maximum duty cycle. All ratings are nominal and based on the actuator being broken-in for approximately 2500 inches of travel.
- The thermal overload relay resets in 10 minutes

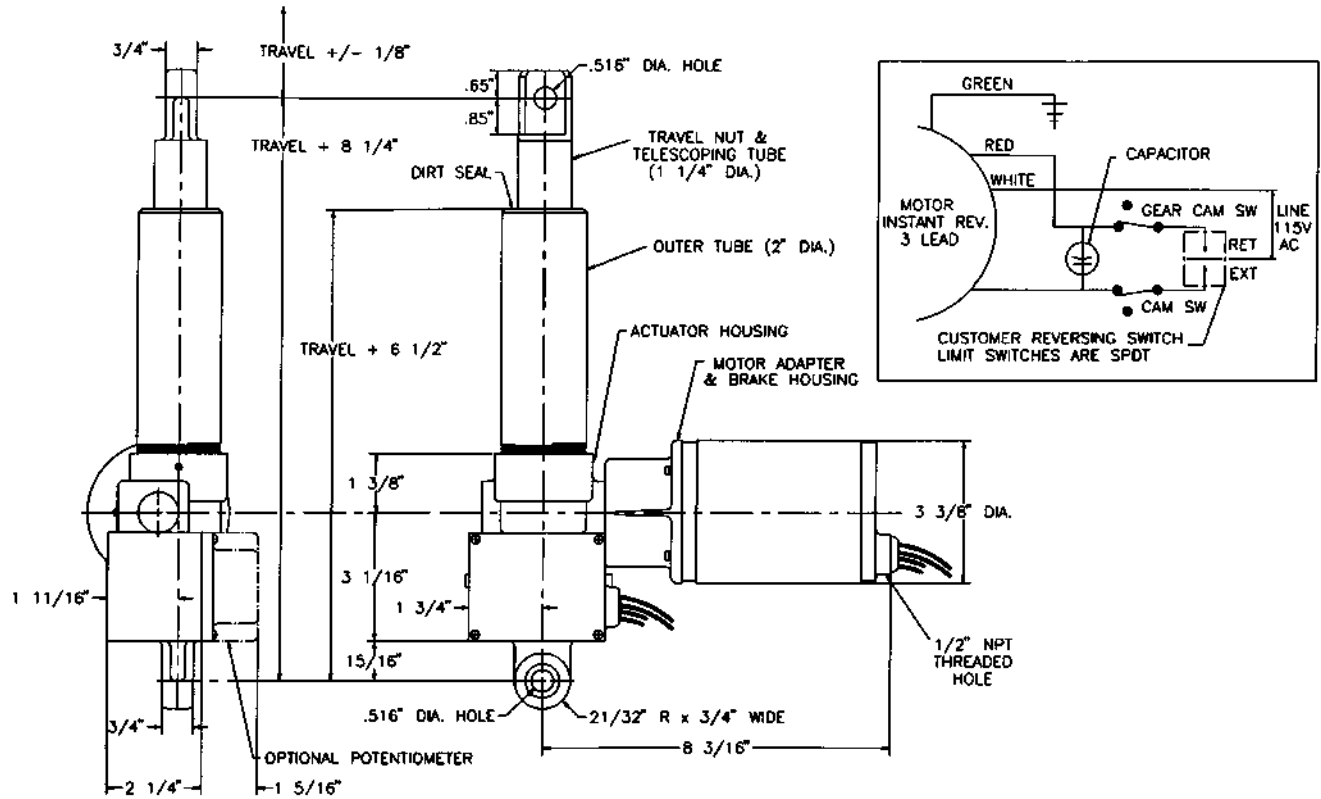

250 Pound Capacity

# Performance Characteristics

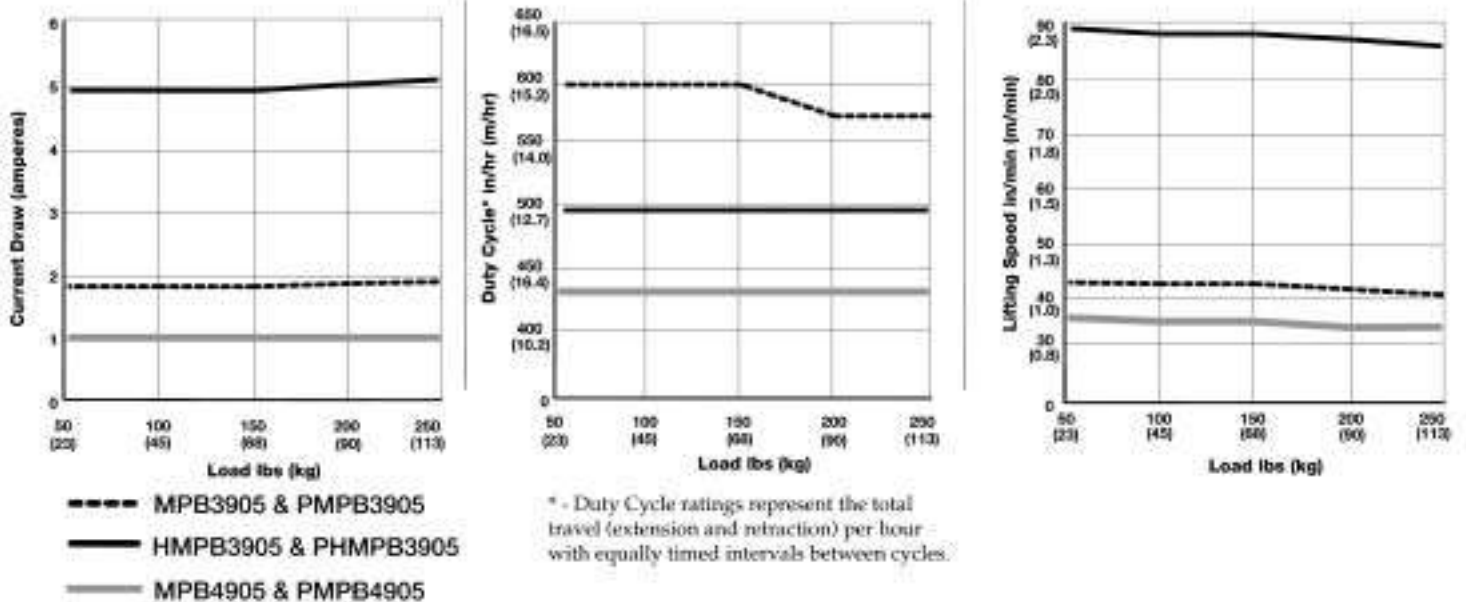



Model Number

**MPD 3405**

*12 VDC with Clutch*

**MPD 3404**

*24 VDC with Clutch*

**HMPD 3405**

*12 VDC High Speed  
with Clutch*

**Specifications**

<b>Stroke Lengths</b>	3, 6, 12 and 18 inch 75, 150, 300, 450 mm	<b>Drive</b>	Double Lead Screw
<b>Motor Protection</b>	Automatic reset thermal overload	<b>Housing</b>	Aluminum alloy
<b>Temperature Range</b>	-20° F to 120° F Ambient -29° C to 50° C	<b>Clutch</b>	Load Limiting Friction Disc
		<b>Standard Mounting</b>	Double Clevis
		<b>Restraining Torque</b>	60 in-lbs; 6.78 N-m
		<b>Brake</b>	Patented Spring Type

12 VDC motor is a totally enclosed, weather resistant, permanent magnet type. Magnets act as a secondary brake for added safety. This type of motor is smaller, cooler running, more efficient and has higher duty cycles than series-wound motors. Lower current draw provides for longer battery life. The motor is also equipped with a thermal overload device that opens and resets automatically. The rotation is reversible by reversing the two color coded leads, and torque is the same in either direction.

24 VDC motor is a totally enclosed, weather resistant, permanent magnet type. This type of motor is smaller, cooler running, more efficient and has higher duty cycles than series wound motors. Lower current draw provides for longer battery life. Rotation is reversible by reversing the two color coded leads. Torque is the same in either direction.

**CONTROLS:**

- Duff-Norton Controls are also available for those actuator models as follows:
- Control Package PDC-1R - MPD3405 and HMPD3405
  - Control Package PDC-2R - MPD3404

**NOTE:**

- Some actuator surfaces may reach 230°F during operation at or near maximum duty cycle. All ratings are nominal and based on the actuator being broken-in for approximately 2500 inches of travel.
- The thermal overload relay resets in 10 minutes



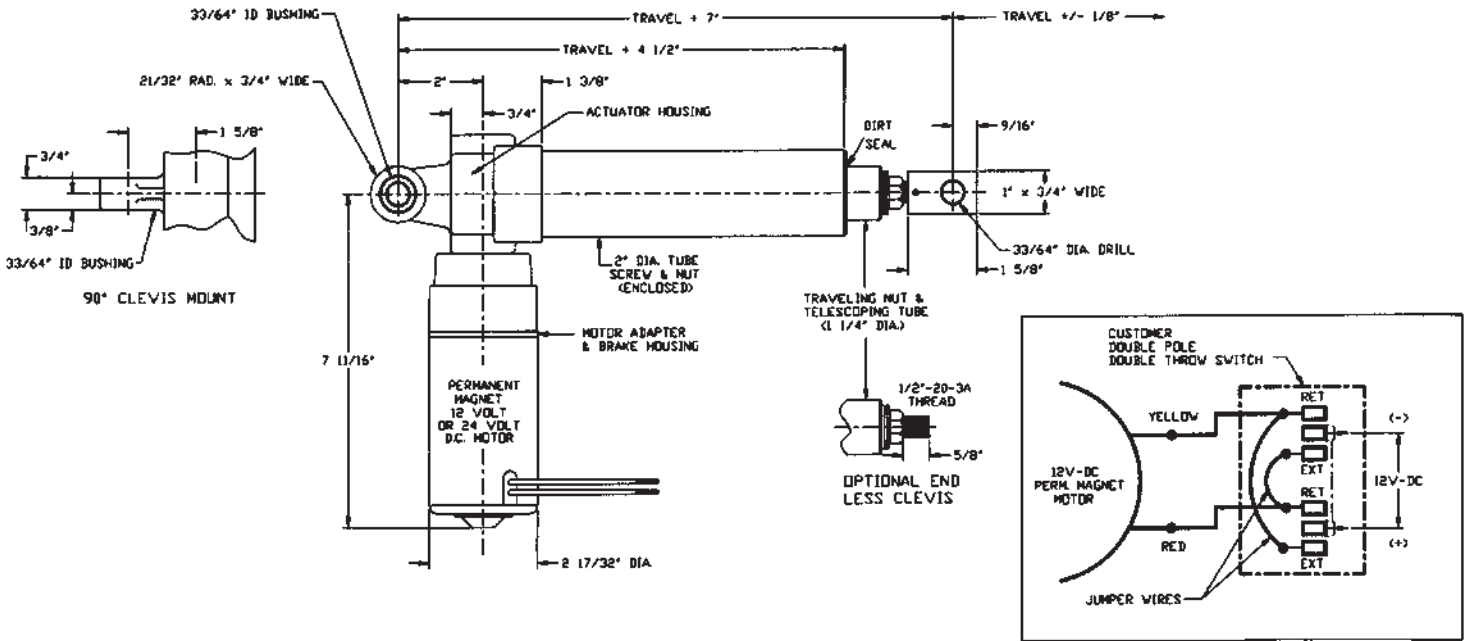

## Performance Characteristics

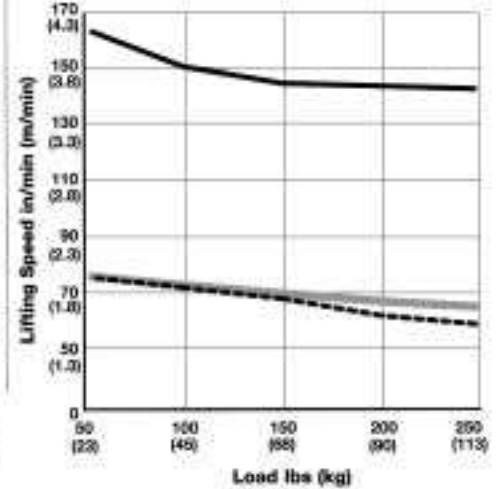
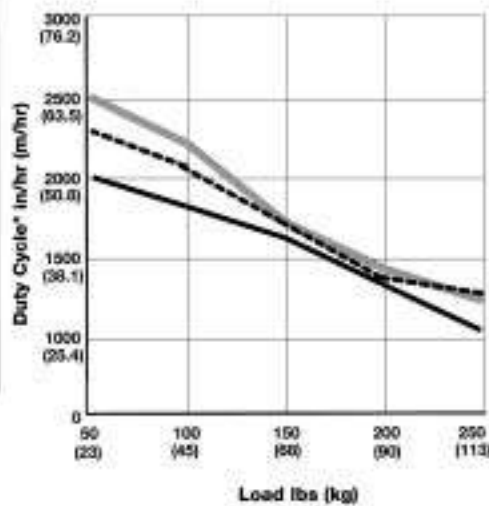
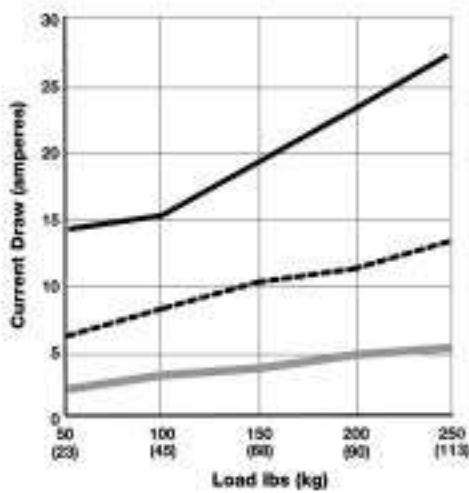

- MPD3405
- HMPD3405
- MPD3404

\* - Duty Cycle ratings represent the total travel (extension and retraction) per hour with equally timed intervals between cycles.



Model Number

**MPD 3905**

*12 VDC with Limit Switches*

**MPD 3904**

*24 VDC with Limit Switches*

**HMPD 3905**

*12 VDC High Speed  
 Limit Switches*

**Specifications**

<b>Stroke Lengths*</b>	3, 6, 12 and 18 inch 75, 150, 300, 450 mm	<b>Drive</b>	Double Lead Screw
<b>Motor Protection</b>	Automatic reset thermal overload	<b>Housing</b>	Aluminum alloy
<b>Temperature Range</b>	-20° F to 120° F Ambient -29° C to 50° C	<b>Clutch</b>	Load Limiting Friction Disc
		<b>Standard Mounting</b>	Double Clevis
		<b>Restraining Torque</b>	60 in-lbs; 6.78 N-m
		<b>Brake</b>	Patented Spring Type

\* IMPORTANT - Stroke lengths are between fixed interval stops. Limit switch should be set at least .250" before stops.

12 VDC motor is a totally enclosed, weather resistant, permanent magnet type. Magnets act as a secondary brake for added safety. This type of motor is smaller, cooler running, more efficient and has higher duty cycles than series-wound motors. Lower current draw provides for longer battery life. The motor is also equipped with a thermal overload device that opens and resets automatically. The rotation is reversible by reversing the two color coded leads, and torque is the same in either direction.

24 VDC motor is a totally enclosed, weather resistant, permanent magnet type. This type of motor is smaller, cooler running, more efficient and has higher duty cycles than series wound motors. Lower current draw provides for longer battery life. Rotation is reversible by reversing the two color coded leads. Torque is the same in either direction.

**CONTROLS:**

- Duff-Norton Controls are also available for those actuator models as follows:
- Control Package PDC-1R - MPD3405 and HMPD3405
  - Control Package PDC-2R - MPD3404

**NOTE:**

- Some actuator surfaces may reach 230°F during operation at or near maximum duty cycle. All ratings are nominal and based on the actuator being broken-in for approximately 2500 inches of travel.
- The thermal overload relay resets in 10 minutes
- Duff-Norton PDC series control box or 2 SPDT Relays (supplied by customer) are required to operate the actuator

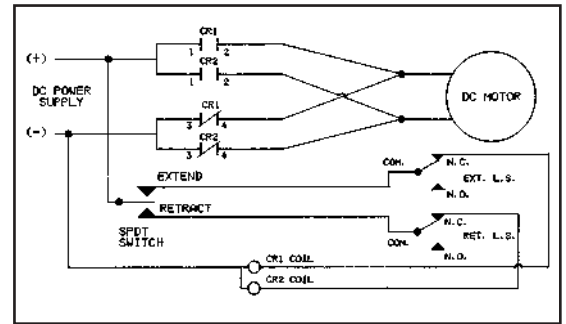
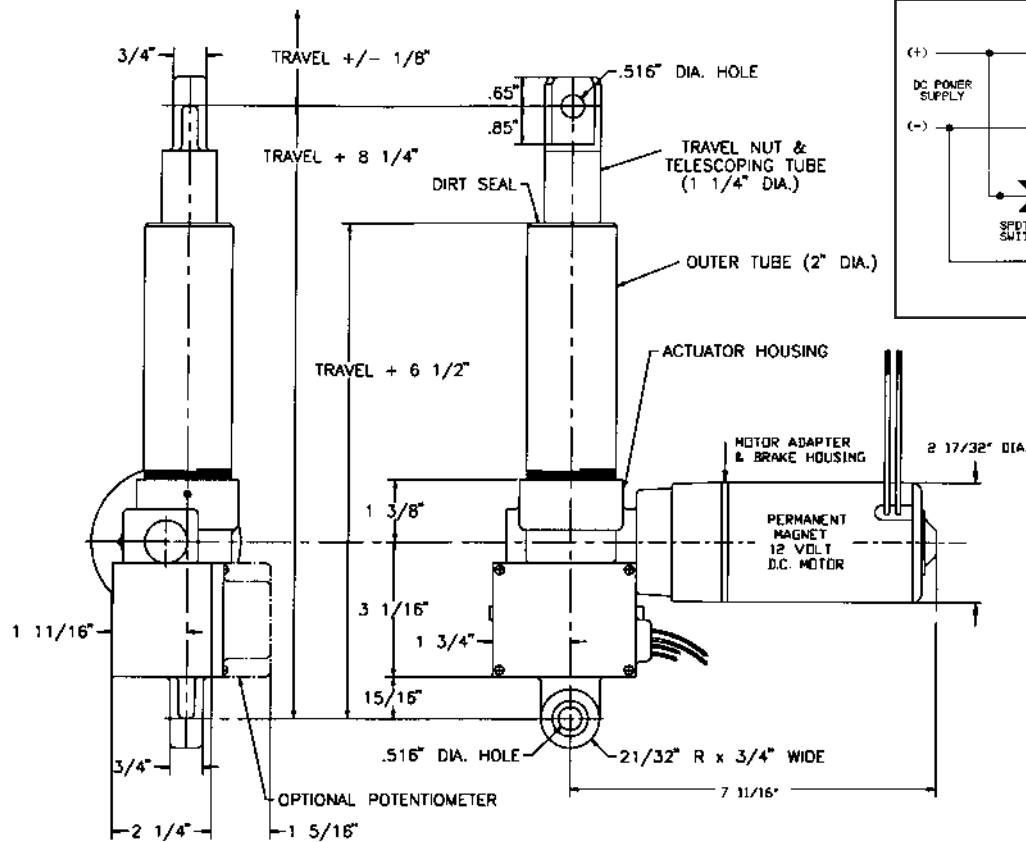

250 Pound Capacity

## Performance Characteristics

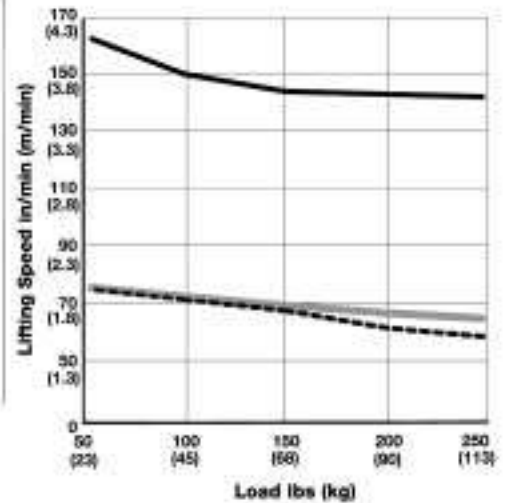
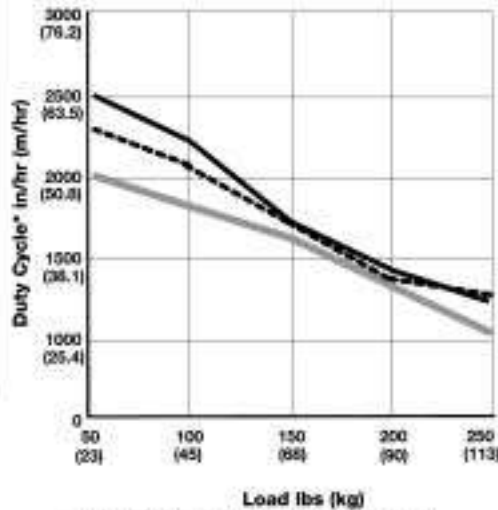
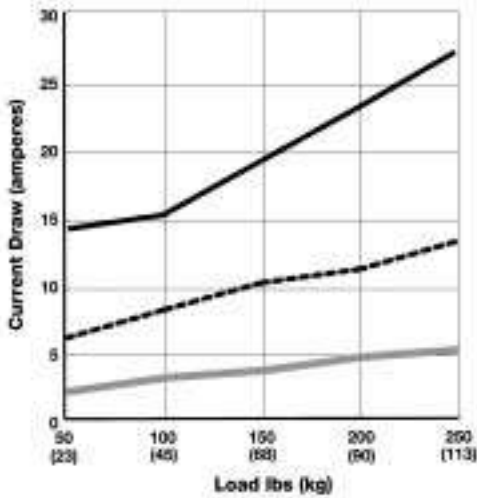

- MPD3905
- HMPD3905
- MPD3904

\* - Duty Cycle ratings represent the total travel (extension and retraction) per hour with equally timed intervals between cycles.

Model Number

**SPB 6405**

*115 VAC (60 Hz) with Clutch*

**SPB 7405**

*220 VAC (50 Hz) with Clutch*

**HSPB 6405**

*115 VAC (60 Hz) High Speed  
with Clutch*



**Specifications**

<b>Stroke Lengths</b>	3, 6, 12 and 18 inch 75, 150, 300, 450 mm	<b>Housing</b>	Aluminum alloy
<b>Motor Protection</b>	Automatic reset thermal overload in motor	<b>Cable Entrance</b>	1/2" NPT
<b>Temperature Range</b>	-20° F to 120° F Ambient -29° C to 50° C	<b>Clutch</b>	Load Limiting Friction Disc
<b>Drive</b>	Double Lead Screw	<b>Standard Mounting</b>	Double Clevis
		<b>Restraining Torque</b>	60 in-lbs; 6.78 N-m
		<b>Brake</b>	Bi-Directional Ball Type

115 VAC motor is an enclosed, permanent split capacitor induction type. Load/no-load speeds are approximately equal. The motor is equipped with a thermal overload device that opens and resets automatically. Standard motor requires 28-33 µfd capacitor supplied by either the customer, or Duff-Norton (SK6405-7-1) at extra cost, for loads up to 250 pounds. High speed motors require a 64-72 ufd capacitor, also available from Duff-Norton (SK6405-7-3). A capacitor box (SK6505-154A) is available on AC models only.

220 VAC motor is a totally enclosed, permanent split capacitor induction type. Load/no-load speeds are approximately equal. Equipped with thermal overload device that opens and resets automatically. Standard motor requires 10 µfd 440VAC, 60/50 Hz metalized polypropylene capacitor supplied by Duff-Norton

**CONTROLS:**

Duff-Norton Controls are also available for these actuator models as follows:

- Control Package BAC-1C for SPB6405
- Control Package BAC-2C for SPB7405

**NOTE:**

- Some actuator surfaces may reach 230°F during operation at or near maximum duty cycle. All ratings are nominal and based on the actuator being broken-in for approximately 2500 inches of travel.
- The thermal overload relay resets in 10 minutes

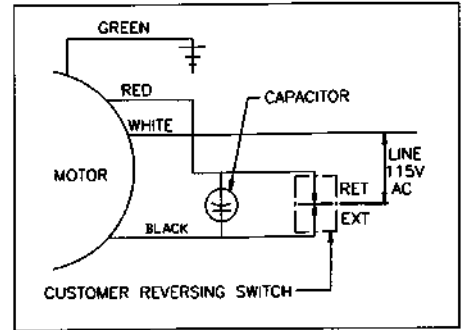
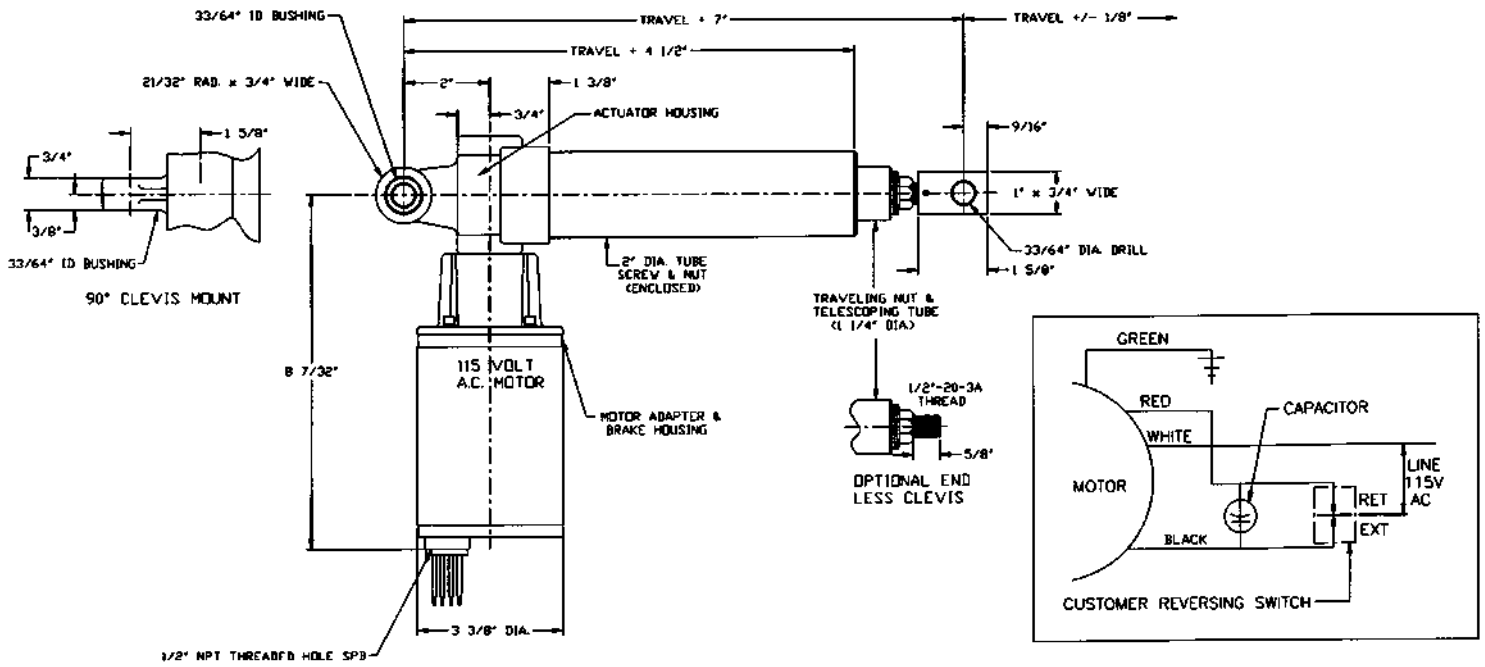

500 Pound Capacity

## Performance Characteristics

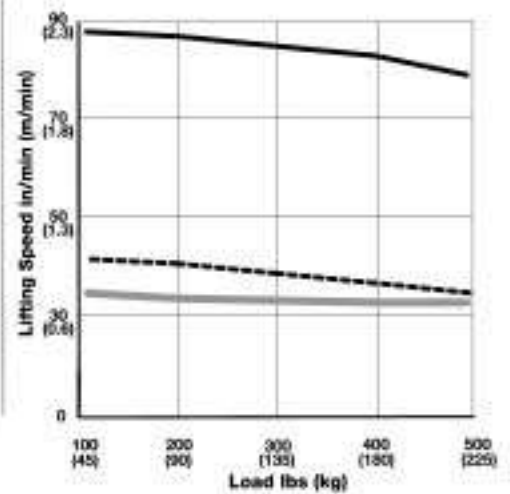
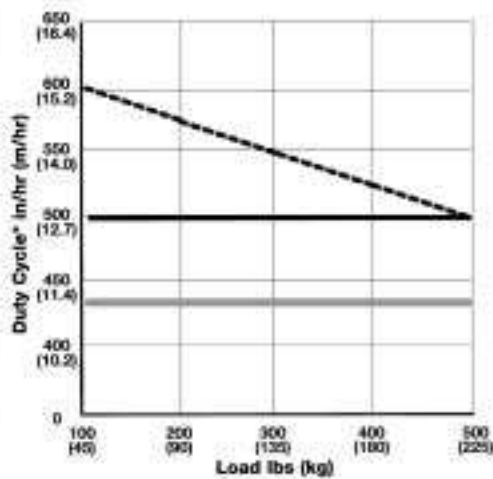
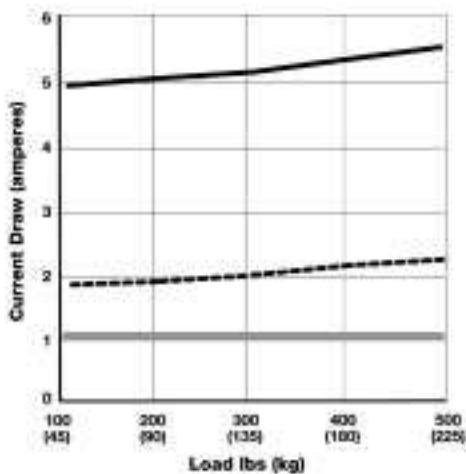

\* - Duty Cycle ratings represent the total travel (extension and retraction) per hour with equally timed intervals between cycles.

- SPB6405
- HSPB6405
- SPB7405



Model Number

**MPB 6905**

*115 VAC (60 Hz) with Limit Switches*

**MPB 7905**

*220 VAC (50 Hz) with Limit Switches*

**HMPB 6905**

*115 VAC (60 Hz) High Speed  
with Limit Switches*

**PMPB 6905**

*115 VAC (60 Hz) with Limit Switches and Potentiometer*

**PMPB 7905**

*220 VAC (50 Hz) with Limit Switches and Potentiometer*

**PHMPB 6905**

*115 VAC (60 Hz) High Speed  
with Limit Switches and Potentiometer*



**Specifications**

<b>Stroke Lengths*</b>	3, 6, 12 and 18 inch 75, 150, 300 and 450 mm	<b>Drive</b>	Double Lead Screw
<b>Motor Protection</b>	Automatic reset thermal overload in motor	<b>Housing</b>	Aluminum alloy
<b>Limit Switches</b>	Dual adjustable	<b>Cable Entrance</b>	1/2" NPT
<b>Temperature Range</b>	-20° F. to 120° F Ambient -29° C to 50° C	<b>Standard Mounting</b>	Double Clevis
		<b>Restraining Torque</b>	60 in-lbs; 6.78 N-m
		<b>Feedback</b>	Potentiometer
		<b>Brake</b>	Bi-Directional Ball Type

\* IMPORTANT - Stroke lengths are between fixed interval stops. Limit switch should be set at least .250" before stops.

**115 VAC** motor is an enclosed, permanent split capacitor induction type. Load/no-load speeds are approximately equal. The motor is equipped with a thermal overload device that opens and resets automatically. Standard motor requires 28-33 µfd capacitor supplied by either the customer, or Duff-Norton (SK6405-7-1) at extra cost, for loads up to 250 pounds. High speed motors require a 64-72 ufd capacitor, also available from Duff-Norton (SK6405-7-3). A capacitor box (SK6505-154A) is available on AC models only.

**220 VAC** motor is a totally enclosed, permanent split capacitor induction type. Load/no-load speeds are approximately equal. Equipped with thermal overload device that opens and resets automatically. Standard motor requires 10 µfd 440VAC, 60/50 Hz metalized polypropylene capacitor supplied by Duff-Norton

**CONTROLS:**

Duff-Norton Controls are also available for these actuator models as follows:

- Control Package BAC-1C for 6905 Series (std. speed)
- Control Package BAC-2C for 7905 Series (std. speed)

**NOTE:**

- Some actuator surfaces may reach 230°F during operation at or near maximum duty cycle. All ratings are nominal and based on the actuator being broken-in for approximately 2500 inches of travel.
- The thermal overload relay resets in 10 minutes

## MPB-6905

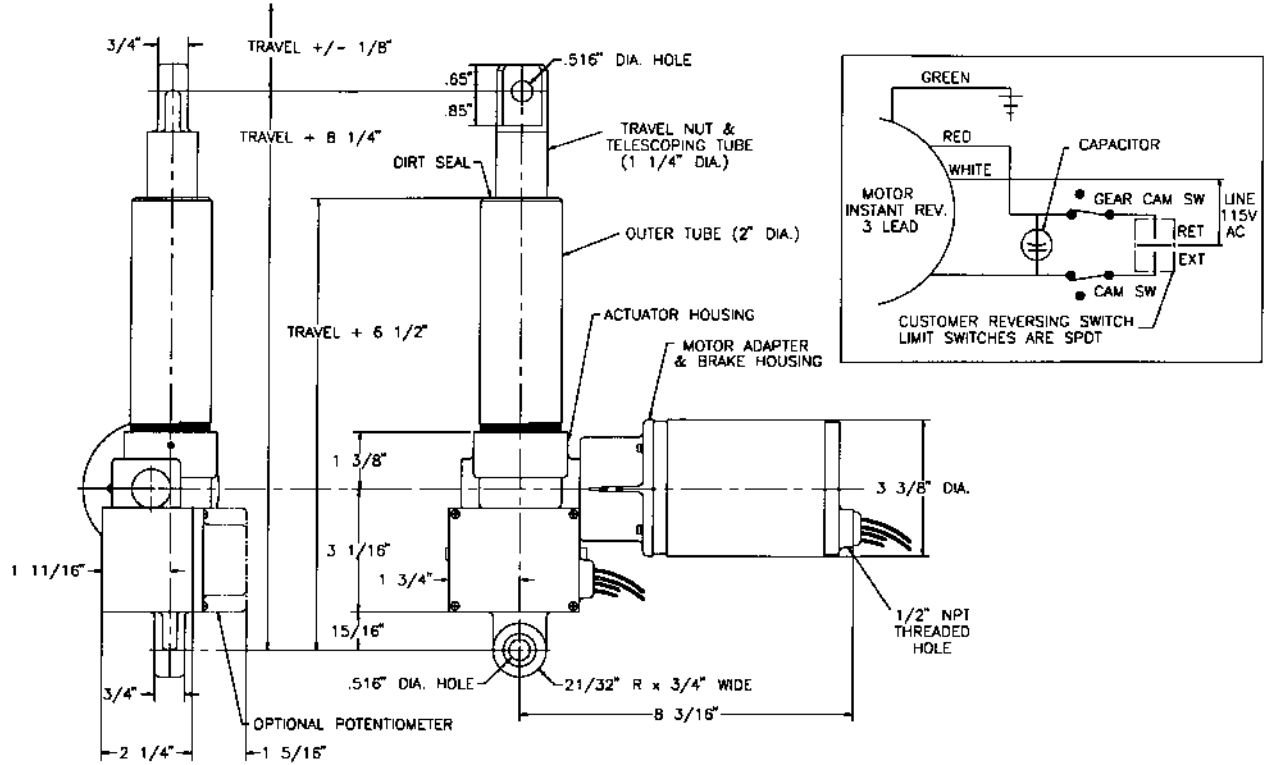

500 Pound Capacity

# Performance Characteristics

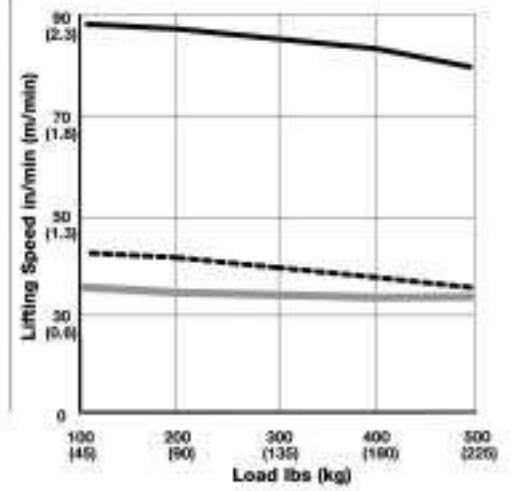
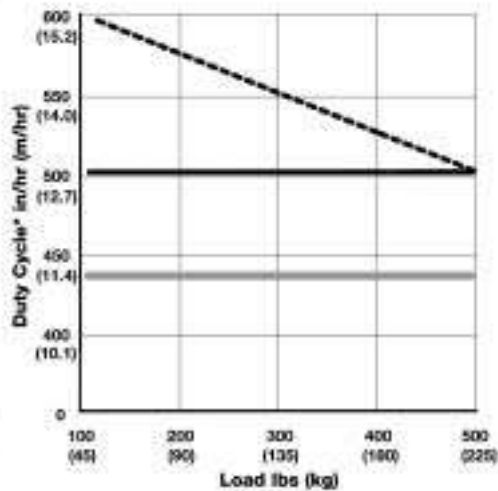
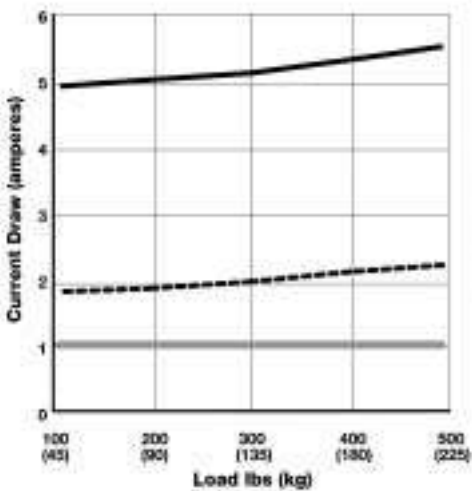

- MPB6905 & PMPB6905
- HMPB6905 & PHMPB6905
- MPB7905 & PMPB7905

\* - Duty Cycle ratings represent the total travel (extension and retraction) per hour with equally timed intervals between cycles.

Model Number

**MPD 6405**  
*12 VDC with Clutch*

**MPD 6404**  
*24 VDC with Clutch*



**Specifications**

<b>Stroke Lengths</b>	3, 6, 12 and 18 inch 75, 150, 300, 450 mm	<b>Drive Housing</b>	Double Lead Screw Aluminum alloy
<b>Motor Protection</b>	Automatic reset thermal overload	<b>Clutch</b>	Load Limiting Friction Disc
<b>Temperature Range</b>	-20° F to 120° F Ambient -29° C to 50° C	<b>Standard Mounting</b>	Double Clevis
		<b>Restraining Torque</b>	60 in-lbs; 6.78 N-m
		<b>Brake</b>	Patented Spring Type

12 VDC motor is a totally enclosed, weather resistant, permanent magnet type. Magnets act as a secondary brake for added safety. This type of motor is smaller, cooler running, more efficient and has higher duty cycles than series-wound motors. Lower current draw provides for longer battery life. The motor is also equipped with a thermal overload device that opens and resets automatically. The rotation is reversible by reversing the two color coded leads, and torque is the same in either direction.

24 VDC motor is a totally enclosed, weather resistant, permanent magnet type. This type of motor is smaller, cooler running, more efficient and has higher duty cycles than series wound motors. Lower current draw provides for longer battery life. Rotation is reversible by reversing the two color coded leads. Torque is the same in either direction.

**CONTROLS:**

Duff-Norton Controls are also available for those actuator models as follows:

- Control Package PDC-1R - MPD6405
- Control Package PDC-2R - MPD6404

**NOTE:**

- Some actuator surfaces may reach 230°F during operation at or near maximum duty cycle. All ratings are nominal and based on the actuator being broken-in for approximately 2500 inches of travel.
- The thermal overload relay resets in 10 minutes

500 Pound Capacity

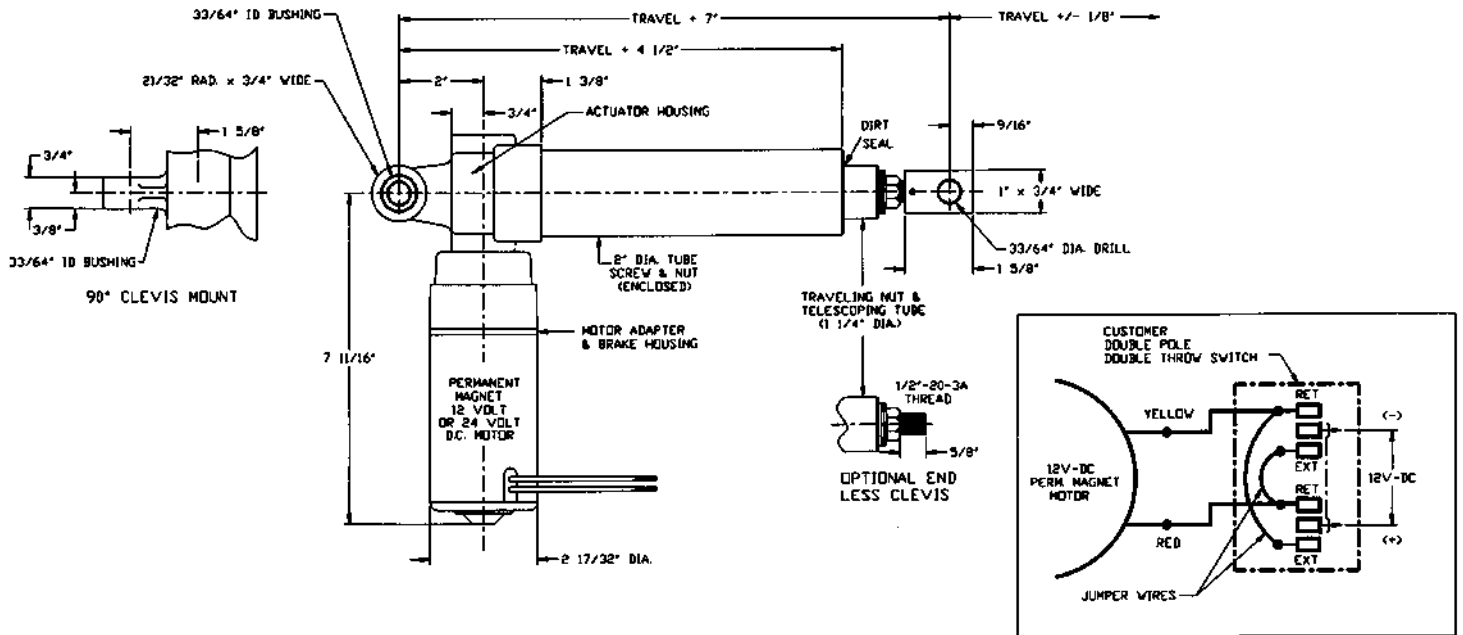

500 Pound Capacity

## Performance Characteristics

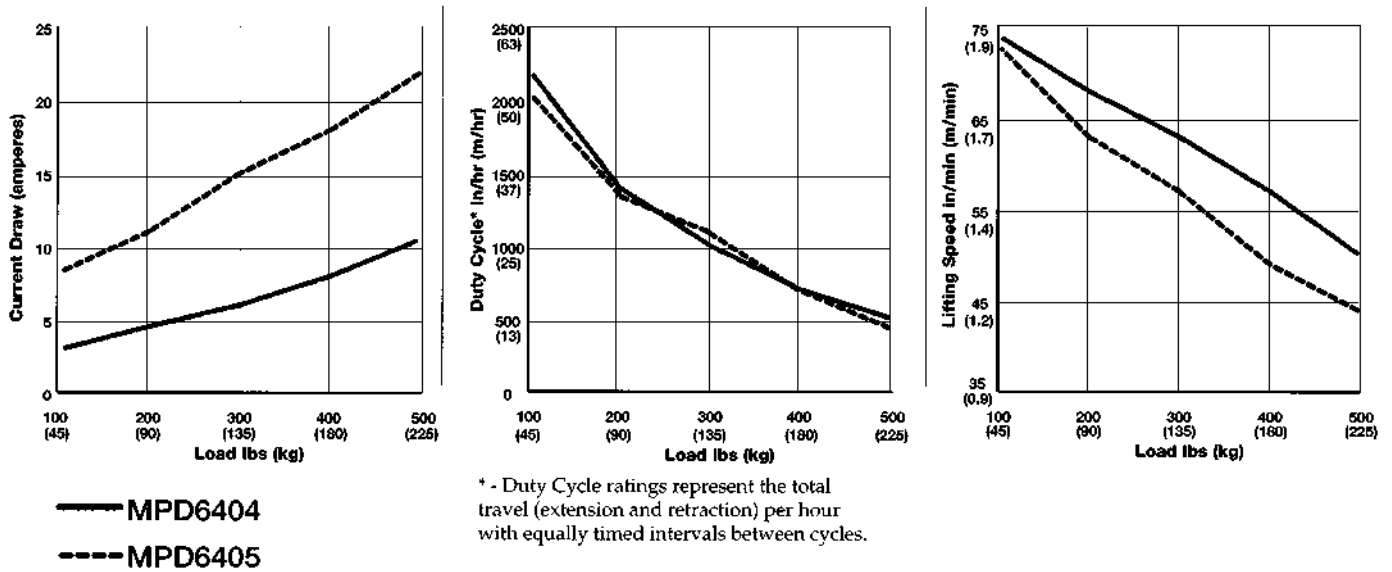



Model Number

**MPD 6905**

*12 VDC with Limit Switches*

**MPD 6904**

*24 VDC with Limit Switches*

**Specifications**

<b>Stroke Lengths*</b>	3, 6, 12 and 18 inch 75, 150, 300, 450 mm	<b>Drive</b>	Double Lead Screw
<b>Motor Protection</b>	Automatic reset thermal overload	<b>Housing</b>	Aluminum alloy
<b>Temperature Range</b>	-20° F to 120° F Ambient -29° C to 50° C	<b>Clutch</b>	Load Limiting Friction Disc
		<b>Standard Mounting</b>	Double Clevis
		<b>Restraining Torque</b>	60 in-lbs; 6.78 N-m
		<b>Brake</b>	Patented Spring Type

\* IMPORTANT - Stroke lengths are between fixed interval stops. Limit switch should be set at least .250" before stops.

12 VDC motor is a totally enclosed, weather resistant, permanent magnet type. Magnets act as a secondary brake for added safety. This type of motor is smaller, cooler running, more efficient and has higher duty cycles than series-wound motors. Lower current draw provides for longer battery life. The motor is also equipped with a thermal overload device that opens and resets automatically. The rotation is reversible by reversing the two color coded leads, and torque is the same in either direction.

24 VDC motor is a totally enclosed, weather resistant, permanent magnet type. This type of motor is smaller, cooler running, more efficient and has higher duty cycles than series wound motors. Lower current draw provides for longer battery life. Rotation is reversible by reversing the two color coded leads. Torque is the same in either direction.

**CONTROLS:**

Duff-Norton Controls are also available for those actuator models as follows:

- Control Package PDC-1R - MPD6905
- Control Package PDC-2R - MPD6904

**NOTE:**

- Some actuator surfaces may reach 230°F during operation at or near maximum duty cycle. All ratings are nominal and based on the actuator being broken-in for approximately 2500 inches of travel.
- The thermal overload relay resets in 10 minutes
- Duff-Norton PDC series control box or 2 SPDT Relays (supplied by customer) are required to operate the actuator

500 Pound Capacity

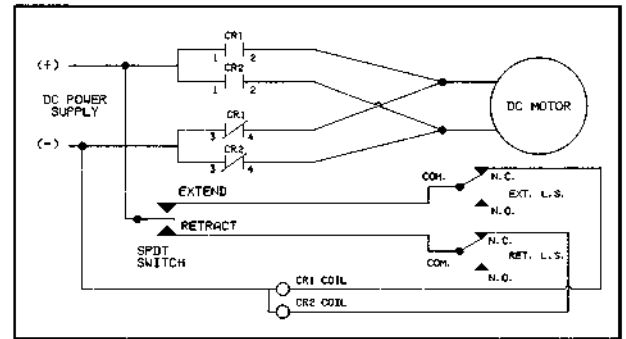
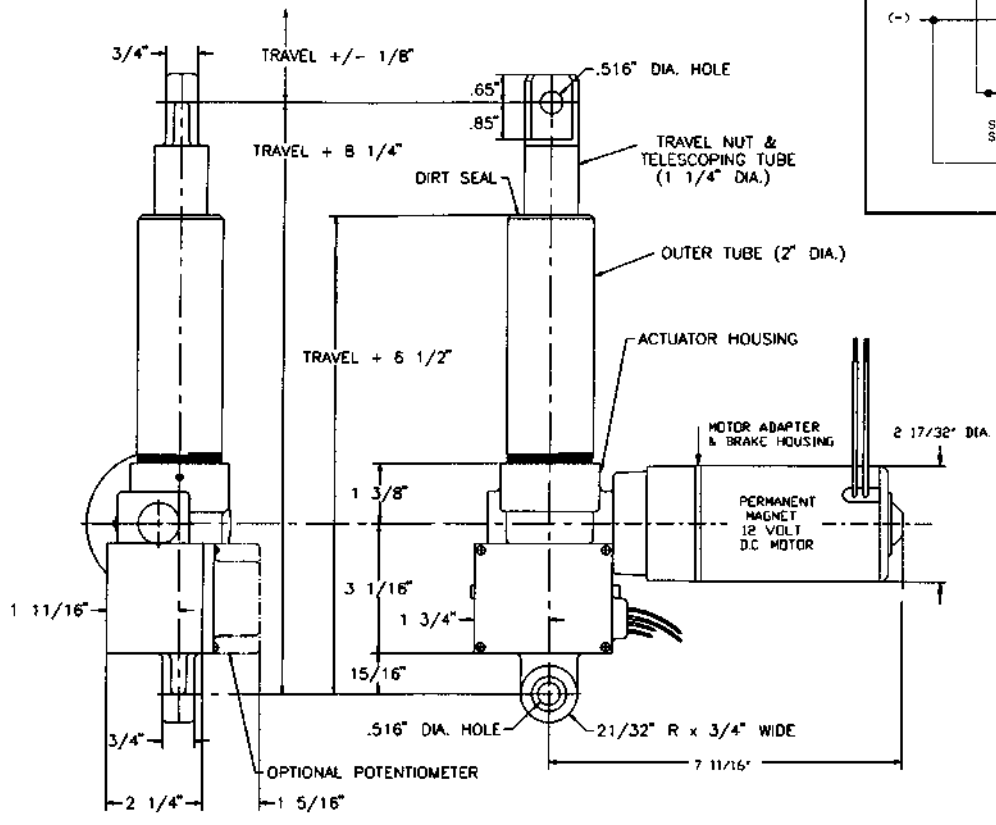

500 Pound Capacity

## Performance Characteristics

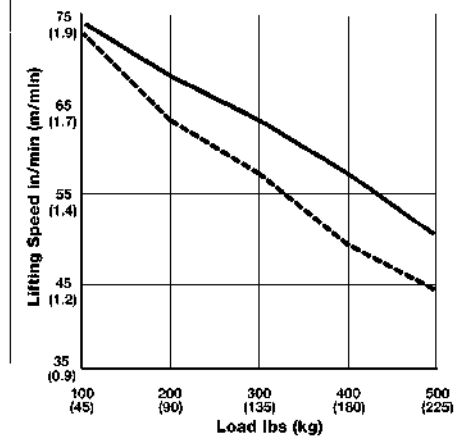
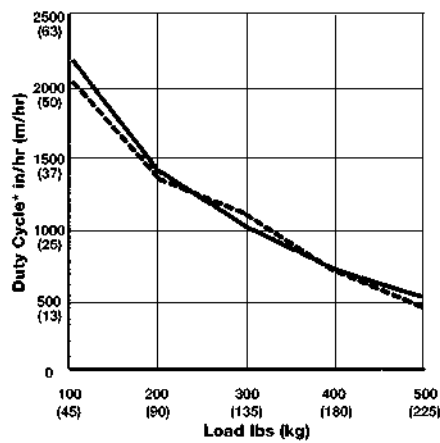
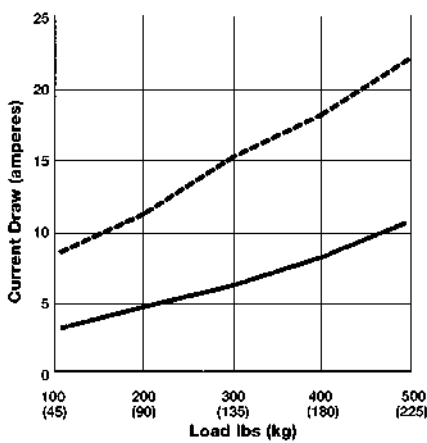

----- MPD6905  
 ———— MPD6904

\* - Duty Cycle ratings represent the total travel (extension and retraction) per hour with equally timed intervals between cycles.



Model Number



**TAL05-1A10**

*115 VAC (60 Hz) with Limit Switches*

**TAP05-1A10**

*115 VAC (60 Hz) with Limit Switches and Potentiometer*

**TAL05-2A10**

*220/230 VAC (50/60 Hz) with Limit Switches*

**TAP05-2A10**

*220/230 VAC (50/60 Hz) with Limit Switches and Potentiometer*

**TAC05-1D20**

*12 VDC with Clutch*

**TAC05-2D20**

*24 VDC with Clutch*

**Specifications**

- Capacity** . . . . . 500 lbs (227 Kgf, 2224N), tension or compression
- Static Load** . . . . . 1000 pounds maximum.
- Motor** . . . . . AC - TENV, permanent - split - capacitor design requiring externally mounted motor run capacitor.  
 DC - Permanent magnet. (Note: All models use automatically resetting thermal protectors)
- Construction** . . . . . Aluminum housing and outer tube, stainless steel translating tube with urethane wiper. Fully sealed and gasketed. Permanently lubricated and maintenance free in normal operation.
- Mounting** . . . . . Clevis each end.
- Drive** . . . . . All-metal gear drive with self-locking Acme screw. Bronze lifting nut.
- Limit Switches** . . . . . (TAL & TAP models): Internal, fully adjustable. With terminal strip for all wiring connections.
- Potentiometer** . . . . . (TAP models): 5000Ω. Approx. 100Ω per inch change.
- Clutch** . . . . . (TAC models): Internal to gearbox; provides overload and jam protection.
- Temperature Range** . . . . . -20 to 120°F (-29 to 49°C)

500 Pound Capacity

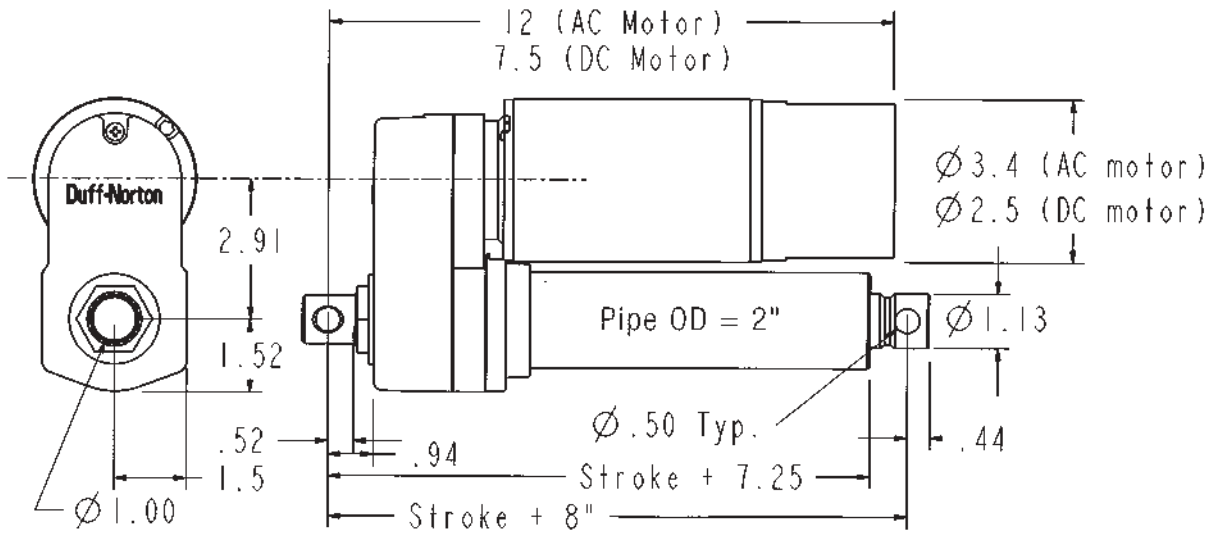

500 Pound Capacity

## Performance Characteristics

Performance at Rated Load

Available Models	Clutch	Limit Switch	Potentiometer	Voltage	Speed	Amps	Duty
TAL05-1A10-#		✓		115Vac, 60 Hz.	52 in/min	4.0 amps	17.5%
TAP05-1A10-#		✓	✓				
TAL05-2A10-#		✓		230Vac, 60 Hz.	54 in/min	2.0 amps	17%
TAP05-2A10-#		✓	✓	[220Vac, 50 Hz]	[45 in/min]	[2.5 amps]	[14%]
TAC05-1D20-#	✓			12 Vdc	27 in/min	10 amps	40%
TAC05-2D20-#	✓			24 Vdc	27 in/min	5 amps	40%

# = Actuator stroke. Standard strokes are 4, 8, and 12 inches [101, 203, and 305mm]. Custom stroke lengths are available.  
 250 Pound rated models (Series TA250) available with double the above speeds.  
 Performance figures at rated load. Data is approximate.

## Wiring

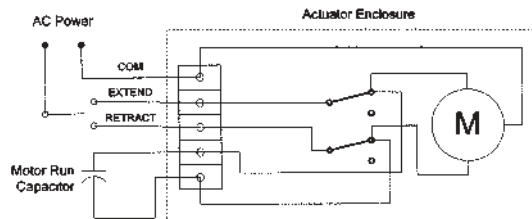

AC Motor Capacitors		
Voltage	Rating	Stock No.
115	50mfd, 370vac	SK6405-7-15
230	15mfd, 440vac	SK6405-7-14

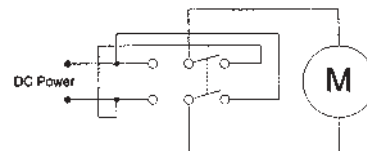

Model Number

**TAL10-1A20**

*115 VAC (60 Hz) with Limit Switches*

**TAP10-1A20**

*115 VAC (60 Hz) with Limit Switches  
and Potentiometer*

**TAL10-2A20**

*220/230 VAC (50/60 Hz) with Limit  
Switches*

**TAP10-2A20**

*220/230 VAC (50/60 Hz) with Limit Switches  
and Potentiometer*



**Specifications**

- Capacity** . . . . . 1000 lbs (454 Kgf, 4448N), tension or compression
- Motor** . . . . . AC - TENV, permanent - split - capacitor design requiring externally mounted motor run capacitor. (Note: All models use automatically resetting thermal protectors)
- Construction** . . . . . Aluminum housing and outer tube, stainless steel translating tube with urethane wiper. Fully sealed and gasketed. Permanently lubricated and maintenance free in normal operation.
- Mounting** . . . . . Clevis each end.
- Drive** . . . . . All-metal gear drive with self-locking Acme screw. Bronze lifting nut.
- Limit Switches** . . . . . Internal, fully adjustable. With terminal strip for all wiring connections.
- Potentiometer** . . . . . (TAP models): 5000Ω. Approx. 200Ω per inch change.
- Temperature Range** . . . . -20 to 120°F (-29 to 49°C)

1000 Pound Capacity

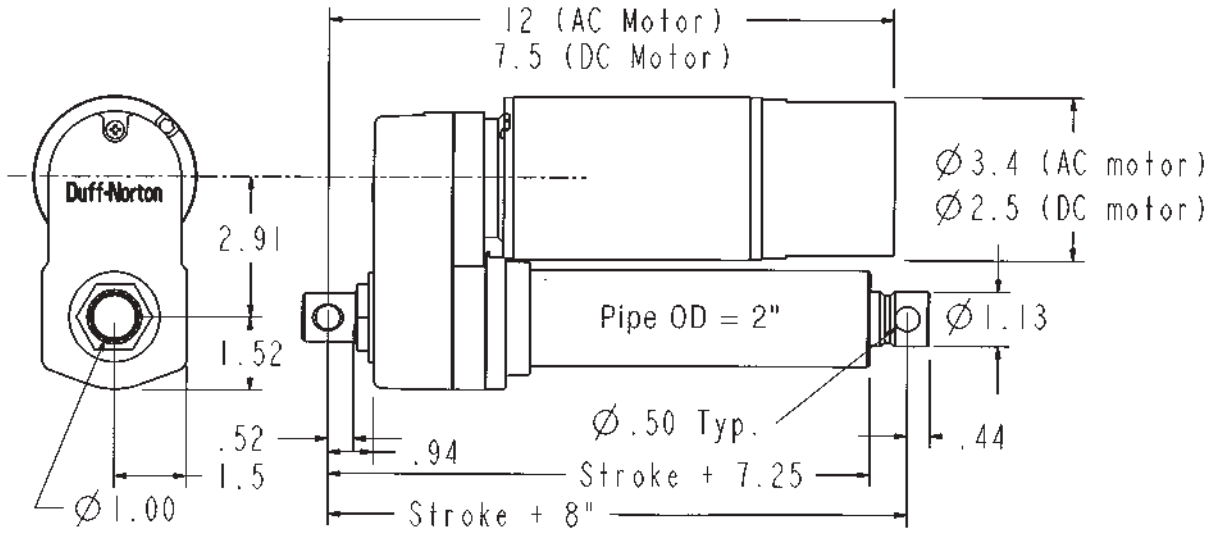

1000 Pound Capacity

## Performance Characteristics

### Performance at Rated Load

Available Models	Limit Switch	Potentiometer	Voltage	Speed	Amps	Duty
TAL10-1A20-#	✓		115Vac, 60 Hz.	26 in/min	4.0 amps	17.5%
TAP10-1A20-#	✓	✓				
TAL10-2A20-#	✓		230Vac, 60 Hz.	27 in/min	2.0 amps	17%
TAP10-2A20-#	✓	✓	[220Vac, 50 Hz]	[22 in/min]	[2.5 amps]	[14%]

# = Actuator stroke. Standard strokes are 4, 8, and 12 inches [101, 203, and 305mm]. Custom stroke lengths are available. Performance figures at rated load. Data is approximate.

## Wiring

AC Motor Capacitors		
Voltage	Rating	Stock No.
115	50mfd, 370vac	SK6405-7-15
230	15mfd, 440vac	SK6405-7-14

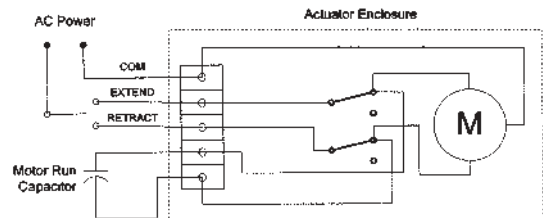

Model Number



**SPA 3410**

*115 VAC (60 Hz) with Limit Switches*

**SPA 4410**

*220 VAC (50 Hz) with Limit Switches*

**PSPA 3410**

*115 VAC (60 Hz) with Limit Switches and Potentiometer*

**PSPA 4410**

*220 VAC (50 Hz) with Limit Switches and Potentiometer*

**Specifications**

<b>Stroke Lengths</b>	3, 6, 12, 18 and 24 inch 75, 150, 300, 450, 610 mm	<b>Drive</b>	Ball Screw
<b>Motor Protection</b>	Automatic reset thermal overload in motor	<b>Housing</b>	Zinc Aluminum die casting
<b>Limit Switches</b>	independent, externally adjustable	<b>Cable Entrance</b>	1/2" NPT and 3/4" NPT
<b>Temperature Range</b>	-20° F. to 120° F Ambient -29° C to 50° C	<b>Standard Mounting</b>	Double Clevis
		<b>Restraining Torque</b>	100 in lbs 11.30 N-m
		<b>Feedback</b>	Potentiometer
		<b>Brake</b>	Electric

**115 VAC** motor is an enclosed, permanent split capacitor induction type. Load/no-load speeds are approximately equal. The motor is equipped with a thermal overload device that opens and resets automatically. The standard motor requires 40 mfd capacitor supplied by either customer, or Duff-Norton(D-N part number: SK-6405-7-12) at extra cost, for loads up to 1000 pounds.

**220 VAC** motor is a totally enclosed, permanent split capacitor induction type. Load/no-load speeds are approximately equal. Equipped with thermal overload device that opens and resets automatically. Standard motor requires 10 µfd 440VAC, 60/50 Hz metalized polypropylene capacitor supplied by either the customer or Duff-Norton (D-N part number: SK-6405-7-10) at extra cost.

**CONTROLS**

- Duff-Norton Controls are also available for these actuator models as follows:
  - Control Package PAC-1CR = PSPA 3410
  - Control Package PAC-2CR =PSPA 4410

**NOTE:**

- Some actuator surface temperatures may reach 230°F at or near maximum allowable duty cycle.
- The thermal overload resets in 10 minutes
- All ratings are normal and based on the actuator being broken in for approximately 2500 inches of travel
- 2 DPST-NO relays (supplied by customer) are required to operate the actuator if the Duff-Norton Controls are not used

1000 Pound Capacity

# Dimensions

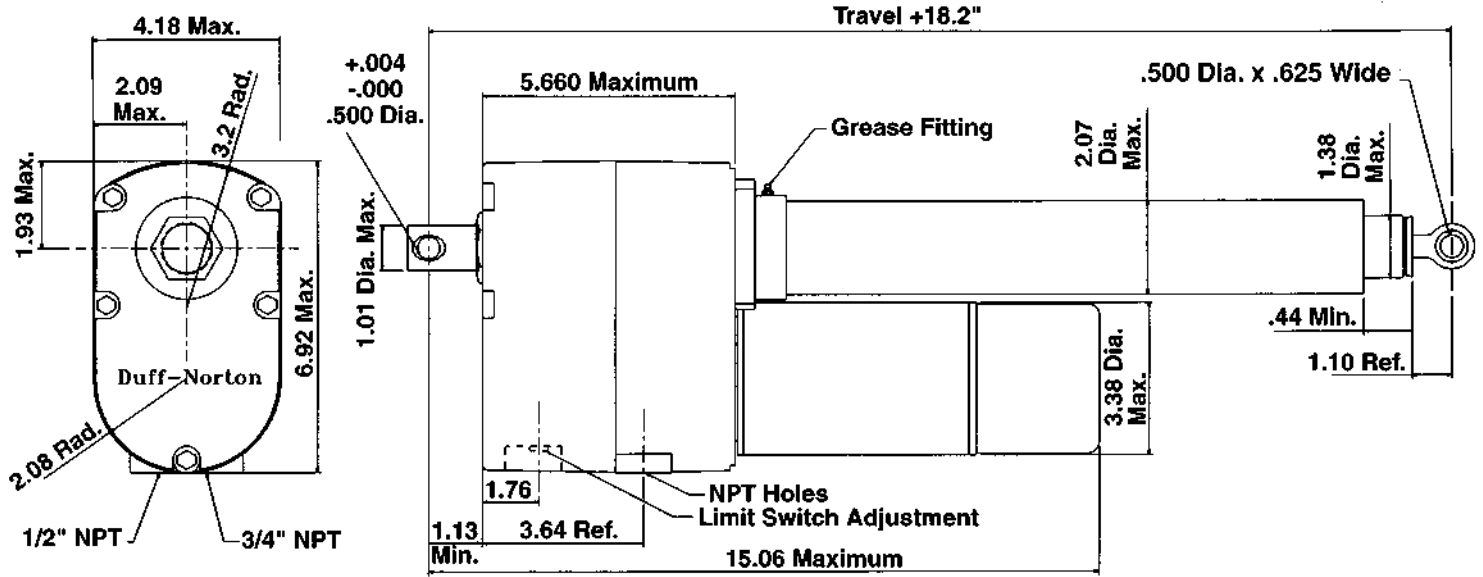

# Wiring

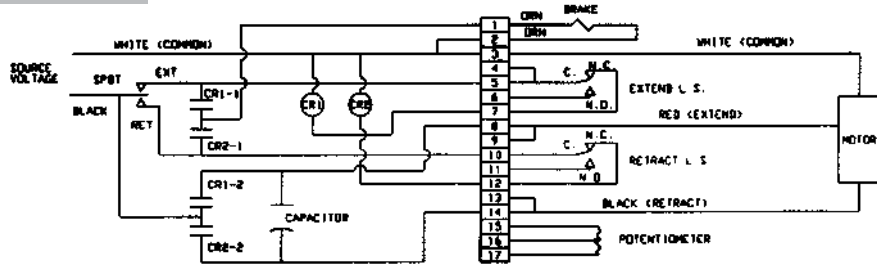

# Performance Characteristics

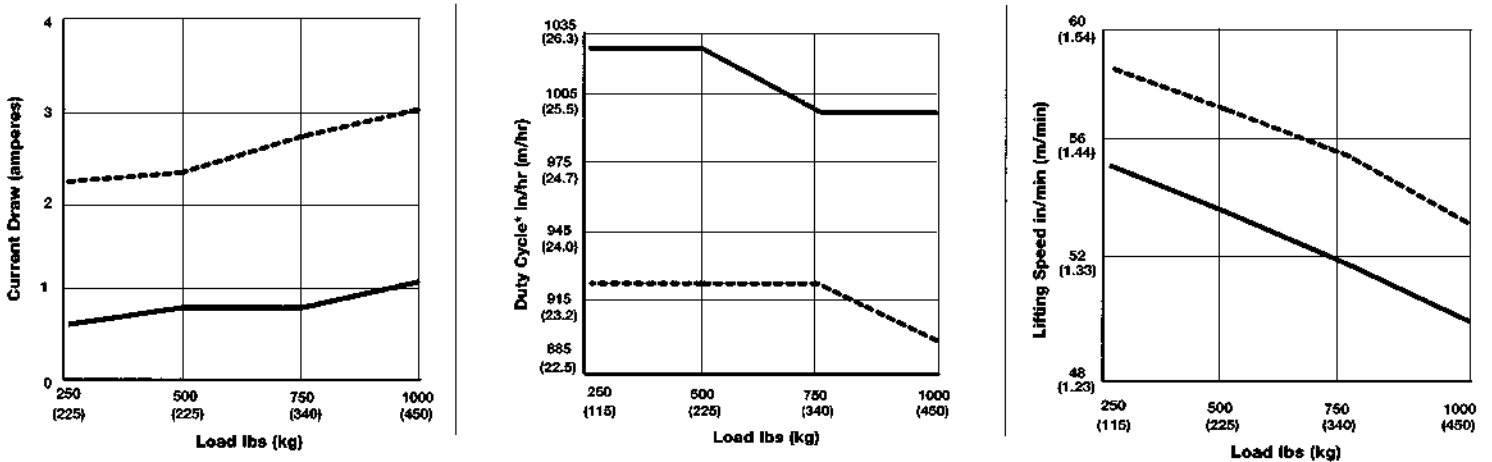

----- PSPA3410  
 ——— PSPA4410

1000 Pound Capacity



## Model Number

### **SPA 6415**

*115 VAC (60 Hz) with Limit Switches*

### **SPA 7415**

*220 VAC (50 Hz) with Limit Switches*

### **PSPA 6415**

*115 VAC (60 Hz) with Limit Switches  
and Potentiometer*

### **PSPA 7415**

*220 VAC (50 Hz) with Limit Switches  
and Potentiometer*



## Specifications

<b>Stroke Lengths</b>	3, 6, 12, 18 and 24 inch 75, 150, 300, 450, 610 mm	<b>Housing</b>	Aluminum alloy
<b>Motor Protection</b>	Automatic reset thermal overload in motor	<b>Cable Entrance</b>	1/2" NPT
<b>Limit Switches</b>	Dual adjustable	<b>Standard Mounting</b>	Double Clevis
<b>Temperature Range</b>	-20° F. to 120° F Ambient -29° C to 50° C	<b>Restraining Torque</b>	190 in lbs. 21.47 N-m
<b>Drive</b>	Double lead screw	<b>Feedback</b>	Potentiometer
		<b>Brake</b>	Bi-Directional Spring Type

**115 VAC** motor is an enclosed, permanent split capacitor induction type. Speeds remain approximately constant regardless of the load. The motor is equipped with a thermal overload device that opens and resets automatically. The standard motor requires 72-88 mfd capacitor supplied by Duff-Norton.

**220 VAC** motor is a totally enclosed, permanent split capacitor induction type. Load/no-load speeds are approximately equal. Equipped with thermal overload device that opens and resets automatically. Standard motor requires 20 µfd 440VAC, 60/50 Hz metalized polypropylene capacitor supplied by Duff-Norton.

### **Note:**

- Some actuator surface temperatures may reach 230°F at or near maximum allowable duty cycle.
- Do not operate actuator before setting limit switches.
- Position hooded vent to prevent moisture and dirt from entering the actuator.
- Actuators are not recommended for applications where the unit can be jammed. Examples of jamming include over traveling the limit switches and jamming the nut and screw internally at the extreme ends of the stroke, or driving the actuator against an immovable object causing the actuator to overload severely.

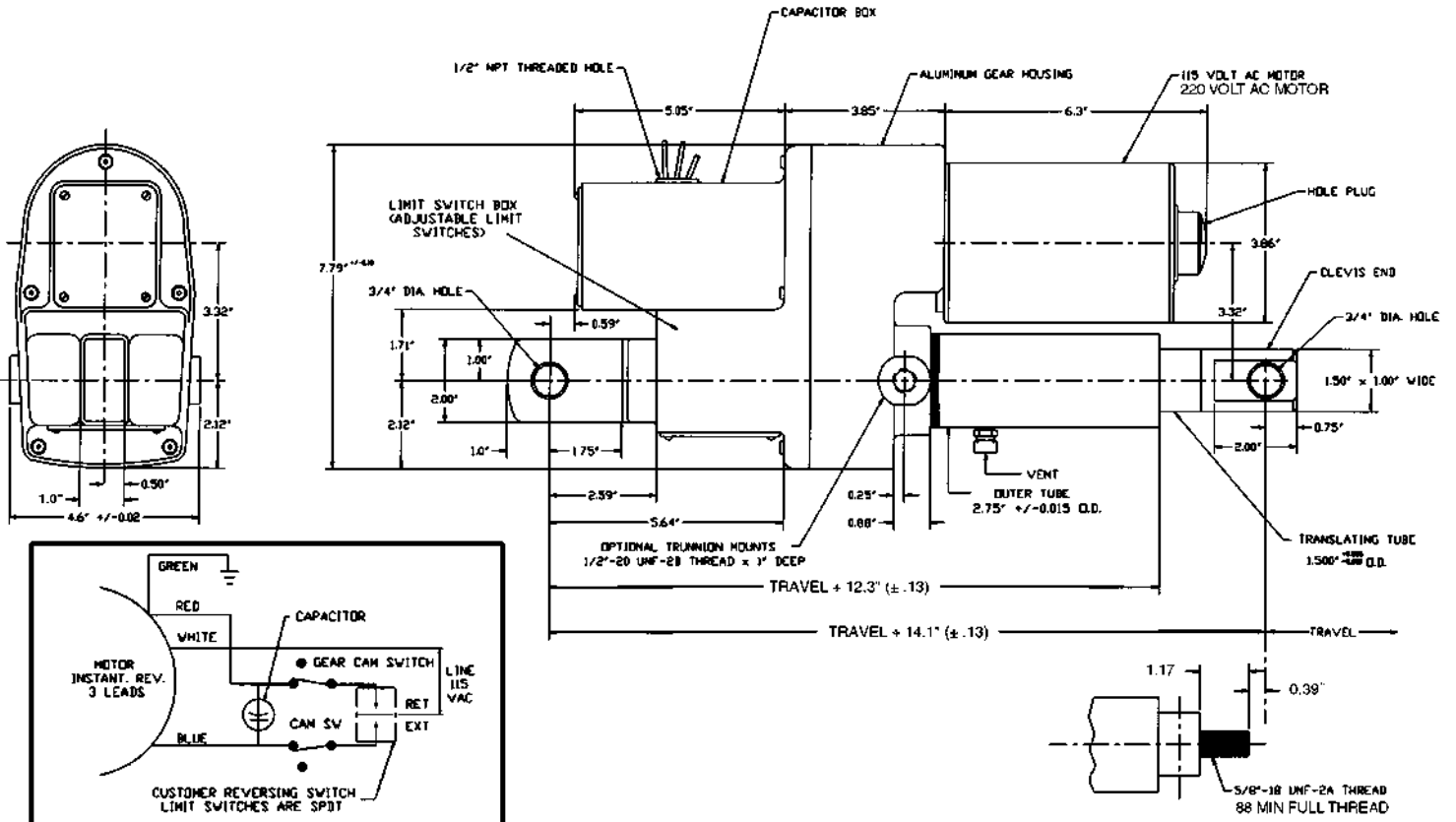

## Performance Characteristics

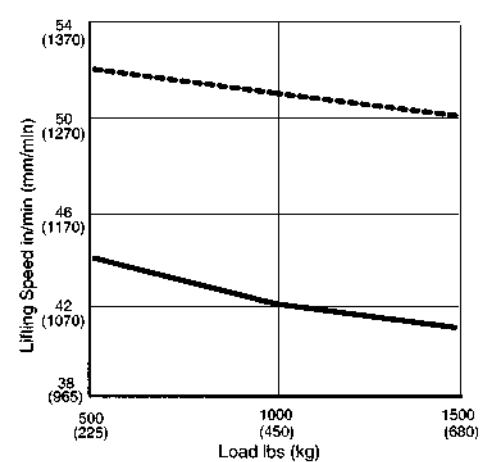
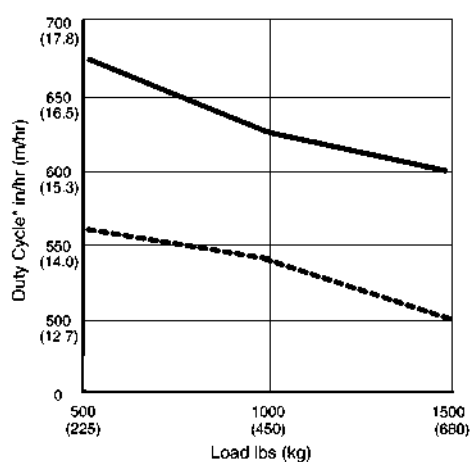
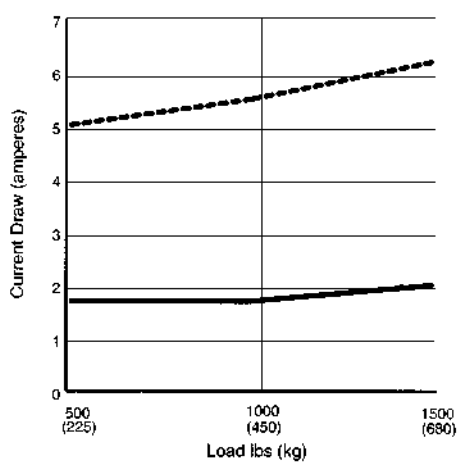

- SPA6415 & PSPA6415
- SPA7415 & PSPA7415

\* - Duty Cycle ratings represent the total travel (extension and retraction) per hour with equally timed intervals between cycles.

1500 Pound Capacity



## Model Number

**SPD 6415**  
*12 VDC with Clutch*

## Specifications

<b>Stroke Lengths</b>	3, 6, 12, 18 and 24 inch 75, 150, 300, 450, 610 mm	<b>Housing</b>	Aluminum alloy
<b>Motor Protection</b>	Thermal protection provided by fuse	<b>Clutch</b>	Load Limiting Friction Disc
<b>Temperature Range</b>	-20° F. to 120° F Ambient -29° C to 50° C	<b>Standard Mounting</b>	Double Clevis
<b>Drive</b>	Double lead screw	<b>Restraining Torque</b>	190 in lbs. 21.47 N-m
		<b>Brake</b>	Bi-Directional Spring Type

**12 VDC** motor is a totally enclosed, weather resistant, permanent magnet type. Magnets act as a secondary brake for added safety. This type of motor is smaller, cooler running, more efficient and has higher duty cycles than series-wound motors. Lower current draw provides for longer battery life. The motor is also equipped with a thermal overload device that opens and resets automatically. The rotation is reversible by reversing the two color coded leads, and torque is the same in either direction.

### Controls

Duff-Norton Controls are also available for the actuator model as follows:  
 - Control Package PDC-1R for SPD 6415

### Note:

- Some actuator surface temperatures may reach 230°F at or near maximum allowable duty cycle.  
 All ratings are nominal and based on the actuator being broken-in for approximately 2500 inches of travel.

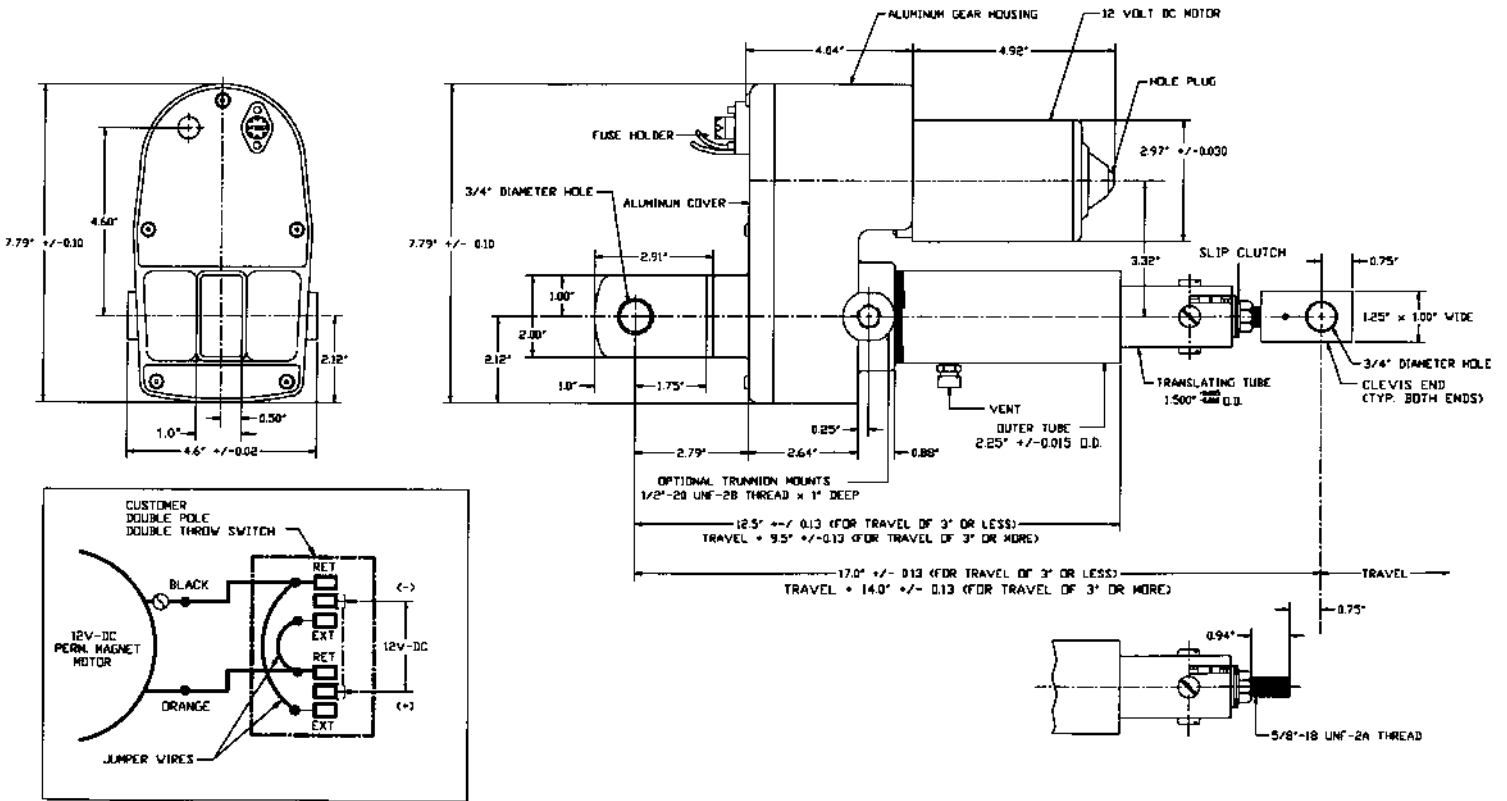

## Performance Characteristics

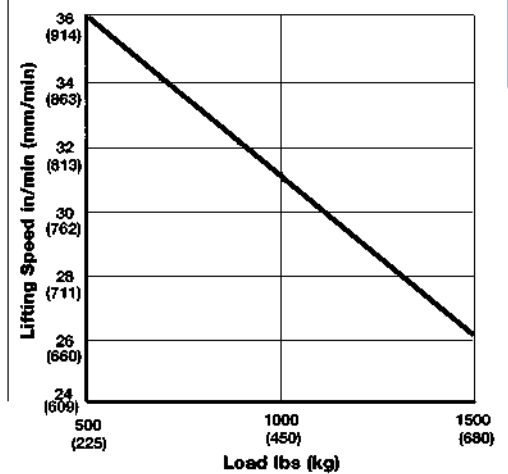
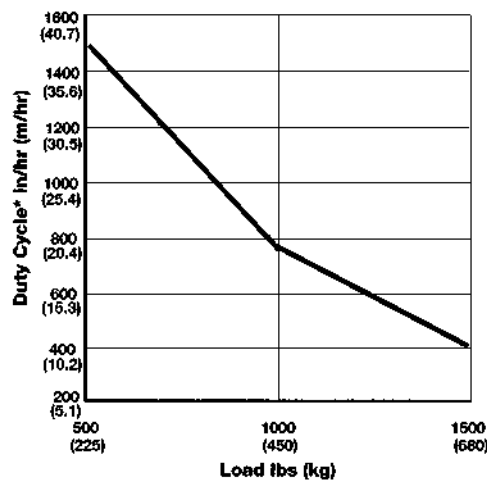
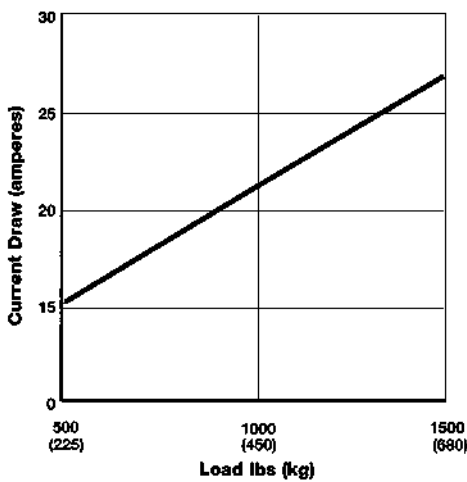

**SPD6415**

\* - Duty Cycle ratings represent the total travel (extension and retraction) per hour with equally timed intervals between cycles.



## Model Number

**LSPD 6415**

*12 VDC with Limit Switches*

## Specifications

<b>Stroke Lengths</b>	3, 6, 12, 18 and 24 inch 75, 150, 300, 450, 610 mm	<b>Housing</b>	Aluminum alloy
<b>Motor Protection</b>	Thermal protection provided by fuse	<b>Standard Mounting</b>	Double Clevis
<b>Temperature Range</b>	-20° F. to 120° F Ambient -29° C to 50° C	<b>Restraining Torque</b>	190 in lbs 21.47 N-m
<b>Drive</b>	Double Lead Screw	<b>Brake</b>	Bi-Directional Spring Type
		<b>Limit Switch</b>	Dual Adjustable
		<b>Cable Entrance</b>	1/2" NPT

12 VDC motor is a totally enclosed, weather resistant, permanent magnet type. Magnets act as a secondary brake for added safety. This type of motor is smaller, cooler running, more efficient and has higher duty cycles than series-wound motors. Lower current draw provides for longer battery life. The motor is also equipped with a thermal overload device that opens and resets automatically. The rotation is reversible by reversing the two color coded leads, and torque is the same in either direction.

### Controls

Duff-Norton Controls are also available for those actuator models as follows:

- Control Package PDC-1R for LSPD6415

### NOTE:

- Some actuator surfaces may reach 230°F during operation at or near maximum duty cycle. All ratings are nominal and based on the actuator being broken-in for approximately 2500 inches of travel.
- Duff-Norton PDC series control box or 2 SPDT Relays (supplied by customers) are required to operate the actuator

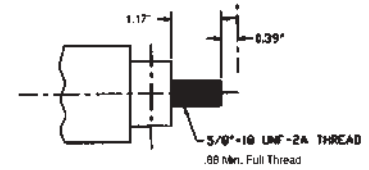
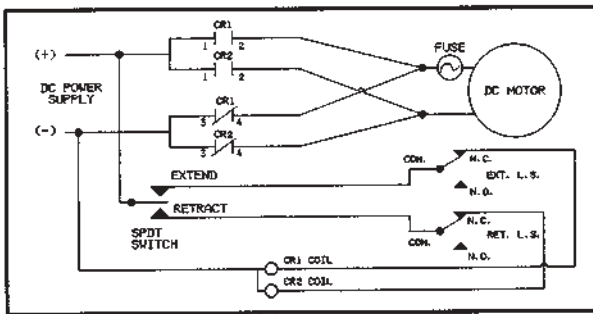
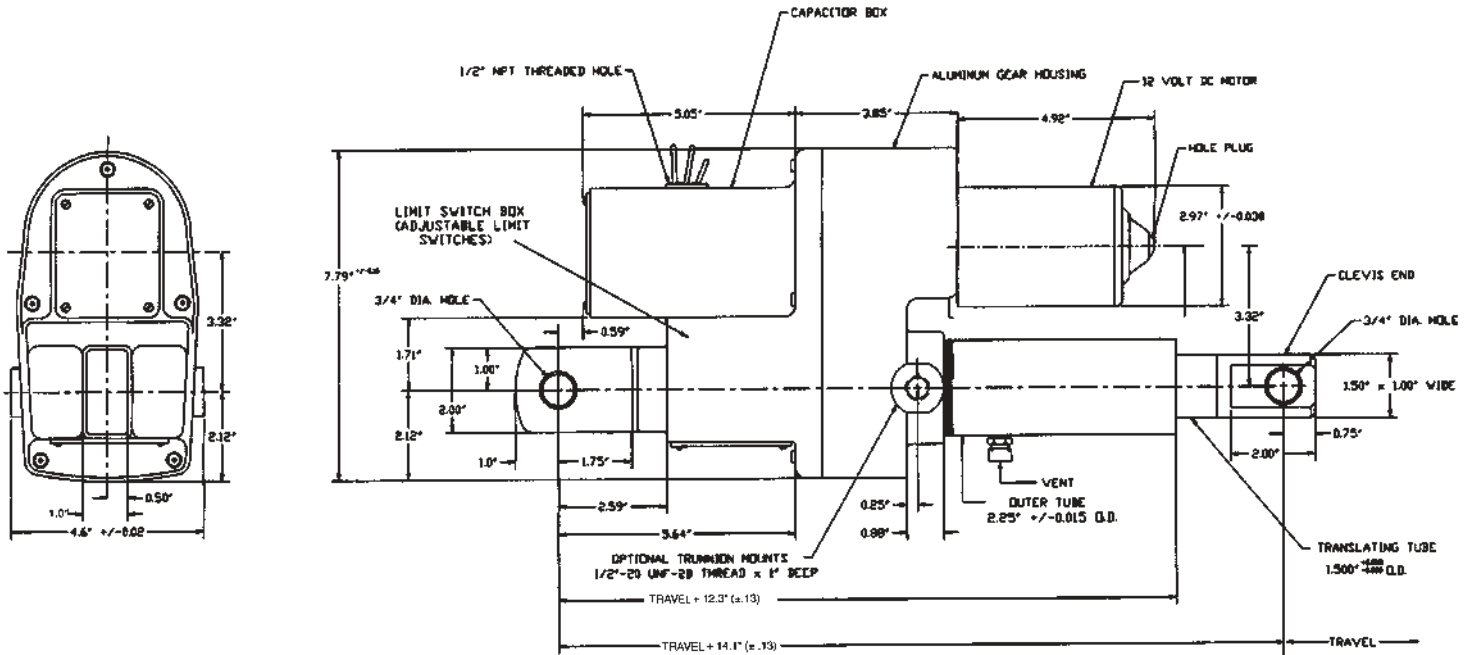

## Performance Characteristics

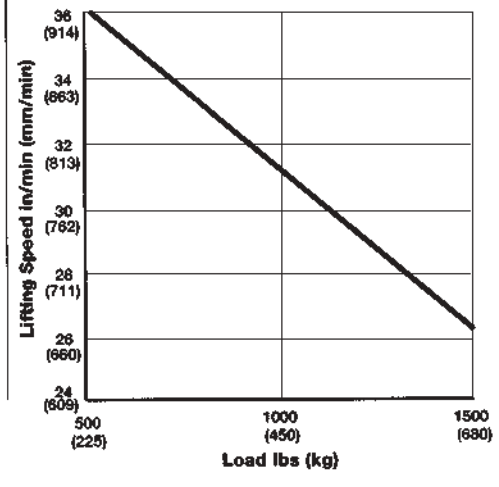
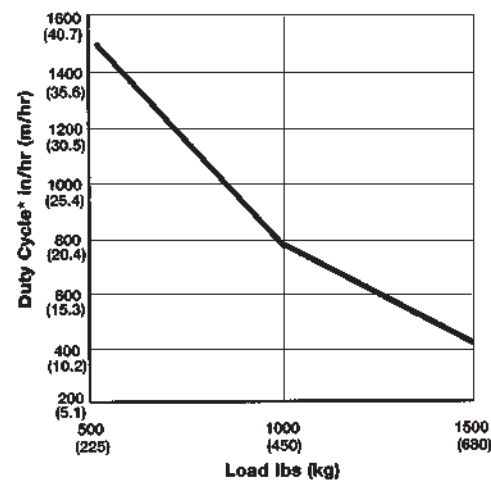
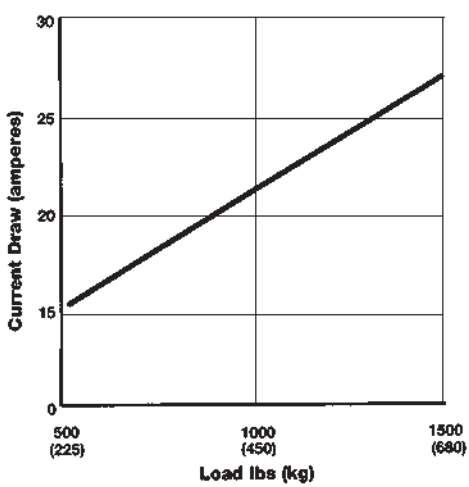

\* - Duty Cycle ratings represent the total travel (extension and retraction) per hour with equally timed intervals between cycles.

**LSPD6415**

TMDL1500-SP

1500 Pound Capacity



## Model Number

### **SPA 6420**

*115 VAC (60 Hz) with Limit Switches*

### **SPA 7420**

*220 VAC (50 Hz) with Limit Switches*

### **PSPA 6420**

*115 VAC (60 Hz) with Limit Switches  
and Potentiometer*

### **PSPA 7420**

*220 VAC (50 Hz) with Limit Switches  
and Potentiometer*



## Specifications

<b>Stroke Lengths</b>	3, 6, 12, 18 and 24 inch 75, 150, 300, 450, 610 mm
<b>Motor Protection</b>	Automatic reset thermal overload in motor
<b>Limit Switches</b>	Dual adjustable
<b>Temperature Range</b>	-20° F. to 120° F Ambient -29° C to 50° C
<b>Drive</b>	Ball Screw and Nut

<b>Housing</b>	Aluminum alloy
<b>Cable Entrance</b>	1/2" NPT
<b>Standard Mounting</b>	Double Clevis
<b>Restraining Torque</b>	190 in lbs. 21.47 N-m
<b>Feedback</b>	Potentiometer
<b>Brake</b>	Automatic Set Spring Type

**115 VAC** motor is an enclosed, permanent split capacitor induction type. Speeds remain approximately constant regardless of the load. The motor is equipped with a thermal overload device that opens and resets automatically. The standard motor requires 72-88 mfd capacitor supplied by Duff-Norton.

**220 VAC** motor is a totally enclosed, permanent split capacitor induction type. Load/no-load speeds are approximately equal. Equipped with thermal overload device that opens and resets automatically. Standard motor requires 20 µfd 440VAC, 60/50 Hz metalized polypropylene capacitor supplied by Duff-Norton.

### **Note:**

- Some actuator surface temperatures may reach 230°F at or near maximum allowable duty cycle.
- Do not operate actuator before setting limit switches.
- Position hooded vent to prevent moisture and dirt from entering the actuator.
- Actuators are not recommended for applications where the unit can be jammed. Examples of jamming include over traveling the limit switches and jamming the nut and screw internally at the extreme ends of the stroke, or driving the actuator against an immovable object causing the actuator to overload severely.

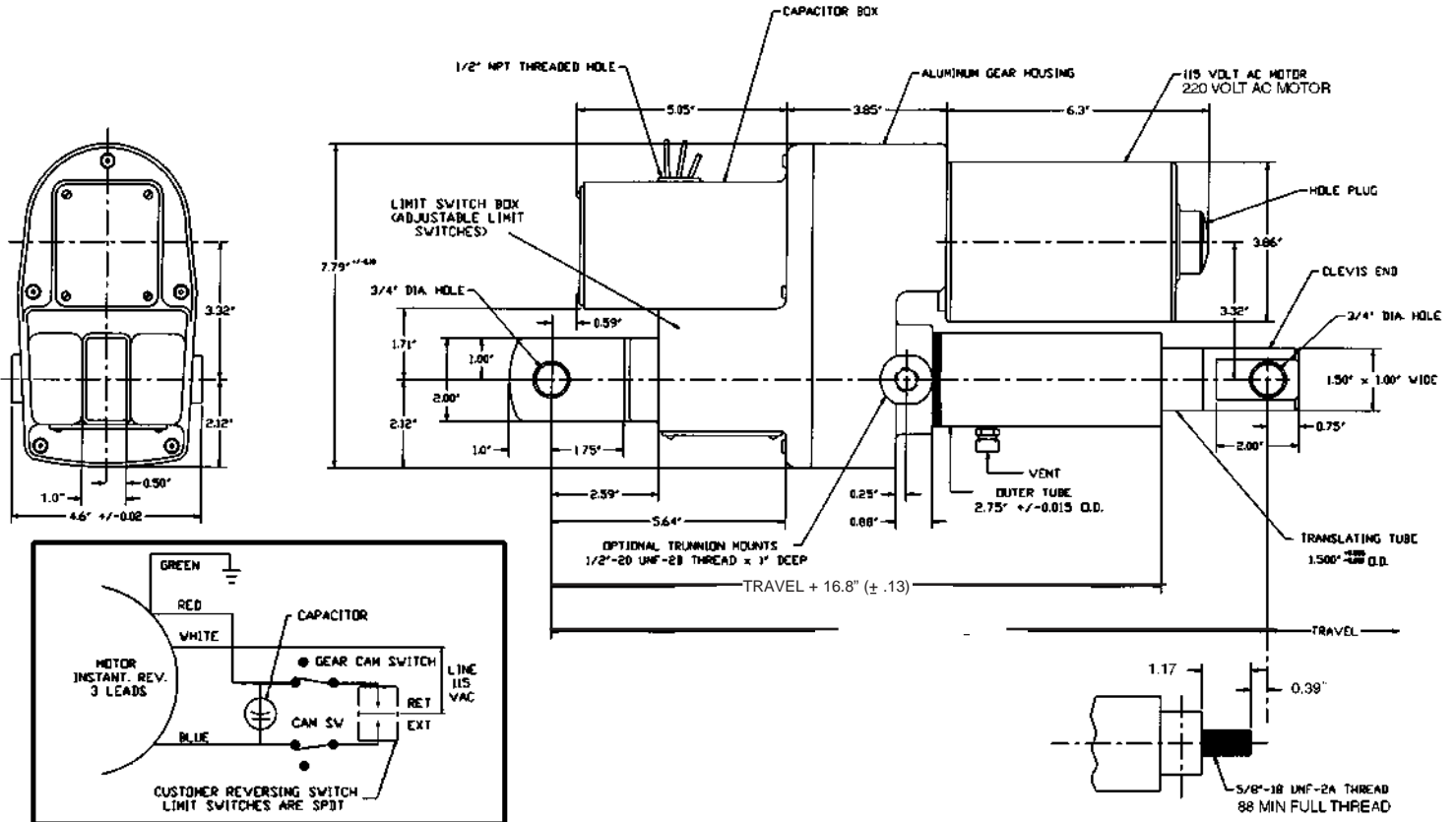

## Performance Characteristics

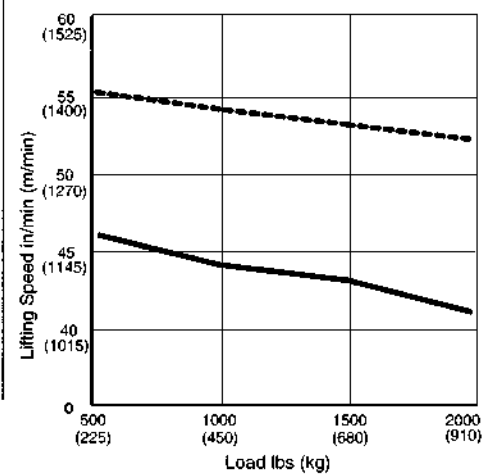
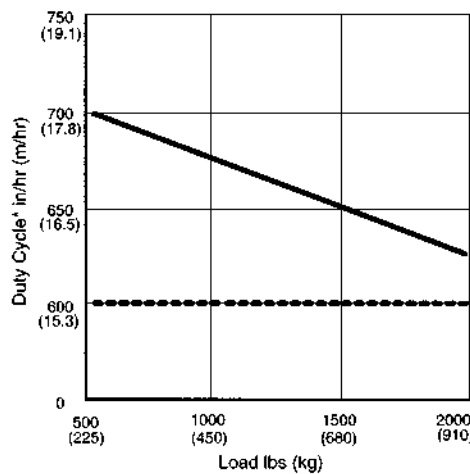
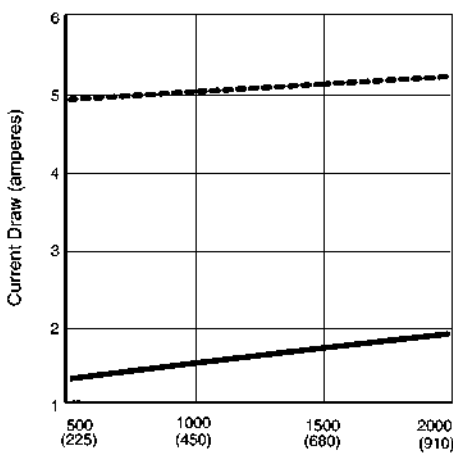

--- SPA6420 & PSPA6420

— SPA7420 & PSPA7420

2000 Pound Capacity



## Model Number

### *Rotating Machine Screw*

**M-2462**  
**M-2463**

### *Translating Tube Machine Screw*

**M-2464**  
**M-2465**

### *Rotating Ball Screw*

**BM-2462**  
**BM-2463**

### *Translating Tube Ball Screw*

**BM-2464**  
**BM-2465**

## Specifications

- Integral housing flange engineered for NEMA 56 frame motor. C-face mounting. (NEMA 42 and 48 and IEC 71 frame motor C-face mounting options available).
- Four basic models: 2 rotating screw with traveling lift nut; 2 translating tube, with protective aluminum outer sleeve.
- Rated loads to 2,000 lbs., depending on actuator gear ratio and motor horsepower.
- Choice of 5:1 or 20:1 worm gear ratios.
- Lift speeds to 170 inches per minute (varies with load and hp/rpm of motor).
- Standard travel up to 24 inches. (Consult Duff-Norton engineering for longer travel options).
- Housing base bolt pattern will accept standard hydraulic and pneumatic accessories.
- Can be tandem-coupled for synchronous operation. Optional motors, limit switches and position indicating transducer available.
- Clevis attachment accessories available for mounting: eye bracket, clevis bracket and pivot pin.

Duff-Norton modular actuators allow design flexibility in matching standard actuator models with drive units specifically selected to meet special or unusual operating conditions. Without time-consuming searches for

"specials," designers can combine standard Duff-Norton modular actuators with AC or DC electric, air, hydraulic or explosion-proof motors to meet a wide range of application conditions.

Each modular actuator (drive motor optional) incorporates a housing mounting flange which will accept NEMA 56 C-face motor mounts (other face options are available).

The rotating screw models, featuring a traveling lift nut, permit reliable load positioning in locations which are relatively free of dust, dirt and moisture. Translating tube units, with an enclosed lifting screw and translating tube, are ideally employed when environmental contamination is anticipated. The availability of optional limit switches and a position indicating transducer (indicates the percent of lift screw travel utilized) enhances the versatility of these actuators in adjusting and precisely positioning rated loads up to 2,000 pounds.

Warning: These actuators are intended for industrial use only and should not be used to lift, support or otherwise transport people unless you have a written statement from Duff-Norton Company which authorizes the specific actuator unit, as used in your application, as suitable for moving people.

Clevis attachments are available for modular actuators. Attachments are suitable for either housing end or translating tube end. Mounting hardware is not included.

## Eye Bracket SK2465-60EB

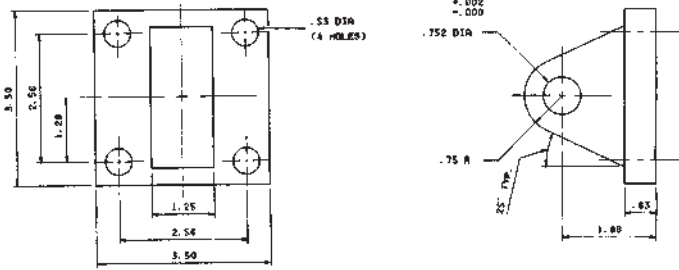

## Clevis Bracket SK2465-61CB

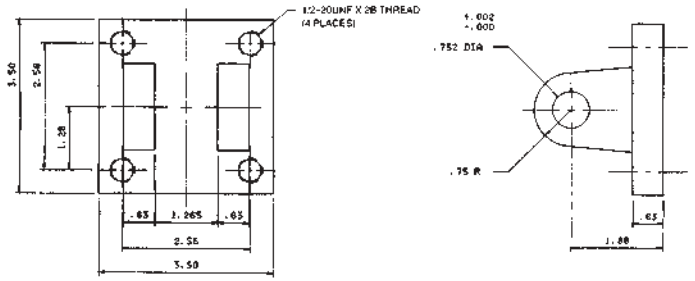

## Pivot Pin SK2465-62PP

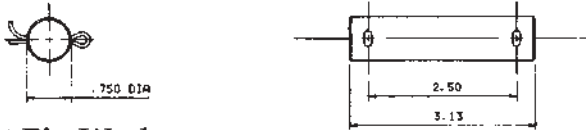

## Pivot Pin Washer H4211C

# Ordering Information

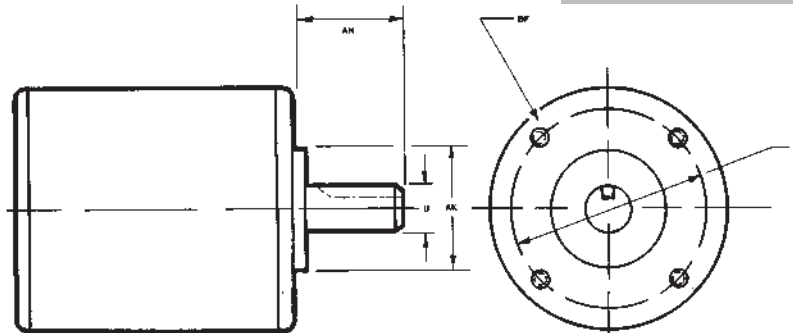

Required Motor Information							
Manufacturer	Type	AH	AK	AJ	U	Key Size	BF

# Limit Switch

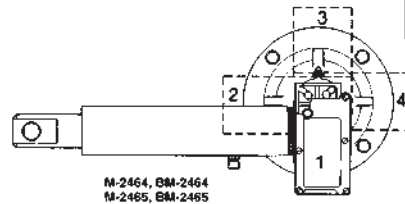
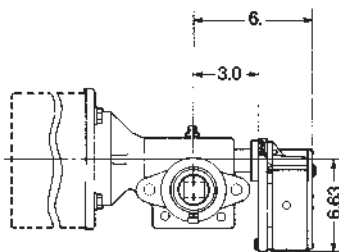

POSITION	1	2	3	4
M-2462, M-2463, BM-2462, BM-2463	C	A	D	C
M-2464, M-2465, BM-2464, BM-2465	C	X	D	C

- (A) MINIMUM POSITION OF NUT MAY BE AFFECTED
- (C) ROTARY LIMIT SWITCH EXTENDS BELOW BASE OF ACTUATOR UNIT.
- (D) SEALED ELECTRIC ELBOW WOULD EXTEND BELOW BASE OF ACTUATOR UNIT.
- (X) RECOMMENDED
- (-) NOT RECOMMENDED

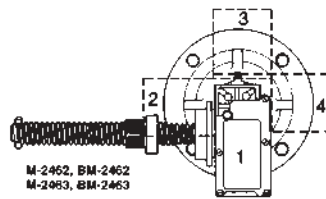

POSITION NO. OF SWITCH

M2400 / BM2400

# Rotating Machine Screw Models

## Dimensions

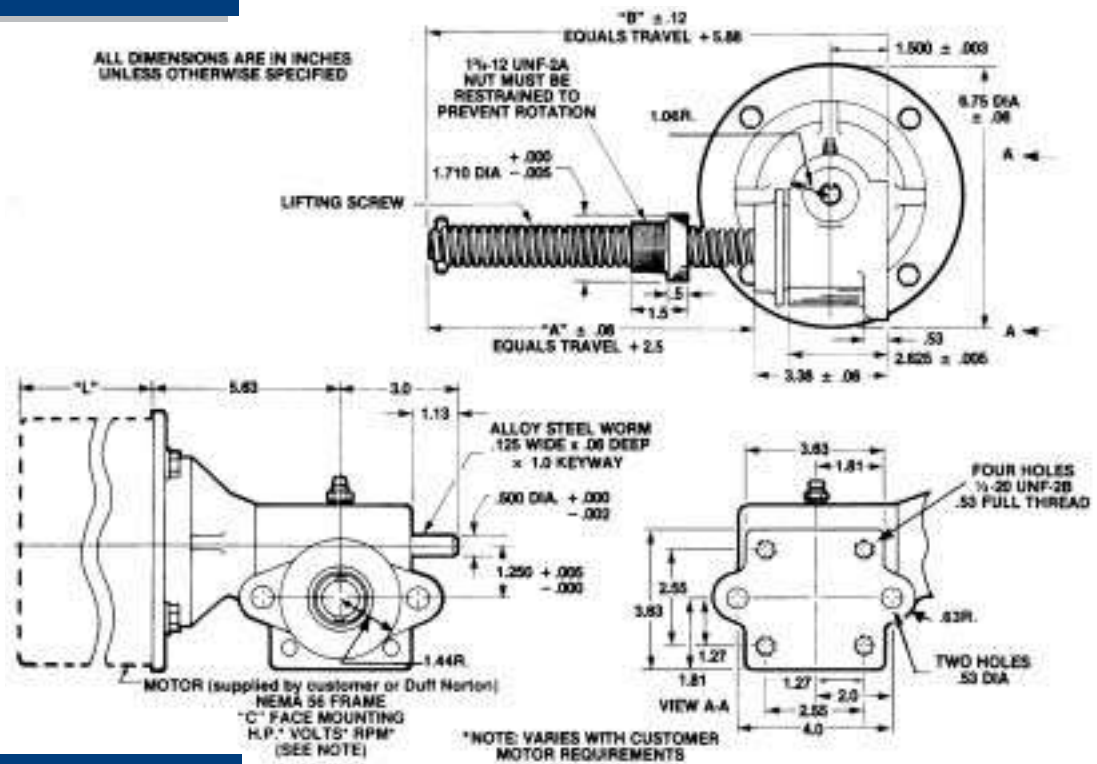

## Specifications

Model No.	"T" Screw Dia.	Turns of Worm/1" Travel		Torque lb./in. @ 1000 lb. Load		Motor RPM	Rated Loads (lbs.)						Lifting Speed in./min./	
		Ratio		Ratio			1/3 HP Motor		1/2 HP Motor		3/4 HP Motor		Ratio	
		5:1	20:1	5:1	20:1		5:1	20:1	5:1	20:1	5:1	20:1	5:1	20:1
M-2462	.875 Dia. Acme .25 Pitch R.H. Double	10	40	39	18	1725	300	700	500	1000	700	1500	170	43
						1140	450	1000	700	1500	1100	2000	114	28
M-2463	1.0 Dia. Acme .25 Pitch R.H. Single	20	80	29	14	1725	400	900	600	1400	900	2000	86	21
						1140	600	1400	900	2000	1400	2000	57	14

- Note:
1. Model M-2462 is self-lowering and a motor brake should be used.
  2. Model M-2463 may drift .75 in. (20:1 ratio) to 2.0 in. (5:1 ratio) when motor is shut off. If this is undesirable, a motor brake should be employed.
  3. When ordering other than 56 C-face actuators, refer to drawing and chart on page 47.

### General Features: Rotating Screw and Translating Tube Models

- Integral 56 frame, C-face mounting flange.
- Three-piece flexible coupling for easy motor assembly (included).
- Four threaded holes in base for standard hydraulic cylinder, clevis end accessory attachment. Tapped  $\frac{1}{4}$ -20 UNF-2B.
- Steel worm and bronze gear set for quiet operation. Available in 5:1 and 20:1 ratios.
- Rolled thread lifting screw, with work-hardened finish, reduces coefficient of friction between screw and lifting nut. Provides smooth, efficient operation and long service.
- Rugged, lightweight aluminum housing is corrosion-resistant.
- Bronze lifting nut for longer life.
- Standard grease fitting on housing for easy lubrication of worm gear.
- Stop-pin at end of lifting screw prevents inadvertent run-off of lifting nut.



## Dimensions

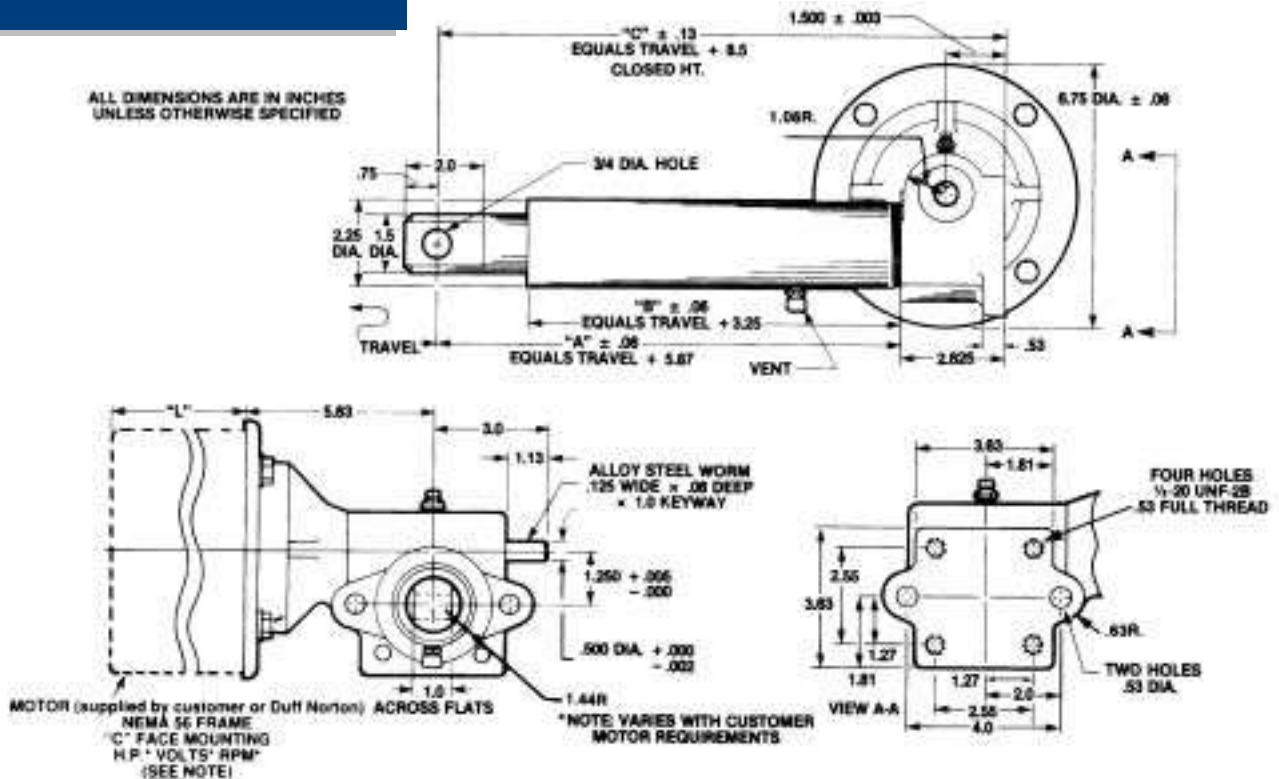

## Specifications

Model No.	"T" Screw Dia.	Turns of Worm/1" Travel		Torque lb./in. @ 1000 lb. Load		Motor RPM	Rated Loads (lbs.)						Lifting Speed in./min/	
		Ratio		Ratio			1/3 HP Motor		1/2 HP Motor		3/4 HP Motor		Ratio	
		5:1	20:1	5:1	20:1		5:1	20:1	5:1	20:1	5:1	20:1	5:1	20:1
M-2464	.875 Dia. Acme .25 Pitch R.H. Double	10	40	39	18	1725	300	700	500	1000	700	1500	170	43
						1140	450	1000	700	1500	1100	2000	114	28
M-2465	1.0 Dia. Acme .25 Pitch R.H. Single	20	80	29	14	1725	400	900	600	1400	900	2000	86	21
						1140	600	1400	900	2000	1400	2000	57	14

- Note:
- Model M-2464 is self-lowering and a motor brake should be used.
  - Model M-2465 may drift .75 in. (20:1 ratio) to 2.0 in. (5:1 ratio) when motor is shut off. If this is undesirable, a motor brake should be employed.
  - When ordering other than 56 C-face actuators, refer to drawing and chart on page 47.

### General Features: Translating Tube Models

- Outer aluminum tube is corrosion-resistant and protects translating tube, lifting screw and nut.
- Wiper-scraper seal in end of outer tube keeps dirt out and lubricants in.
- Bronze guide bushing inside of outer tube reduces lateral movement of translating screw.
- Translating tube is zinc-coated for weather-resistance.
- Single or double lead lifting screw and nut for high efficiency and long wear.
- Vent in outer tube prevents pressure build-up in the actuator.
- Furnished with standard clevis end.
- Threaded end is available; and on special order, depending on application, any type of threaded connection may be substituted.



# Rotating Ball Screw Models

## Dimensions

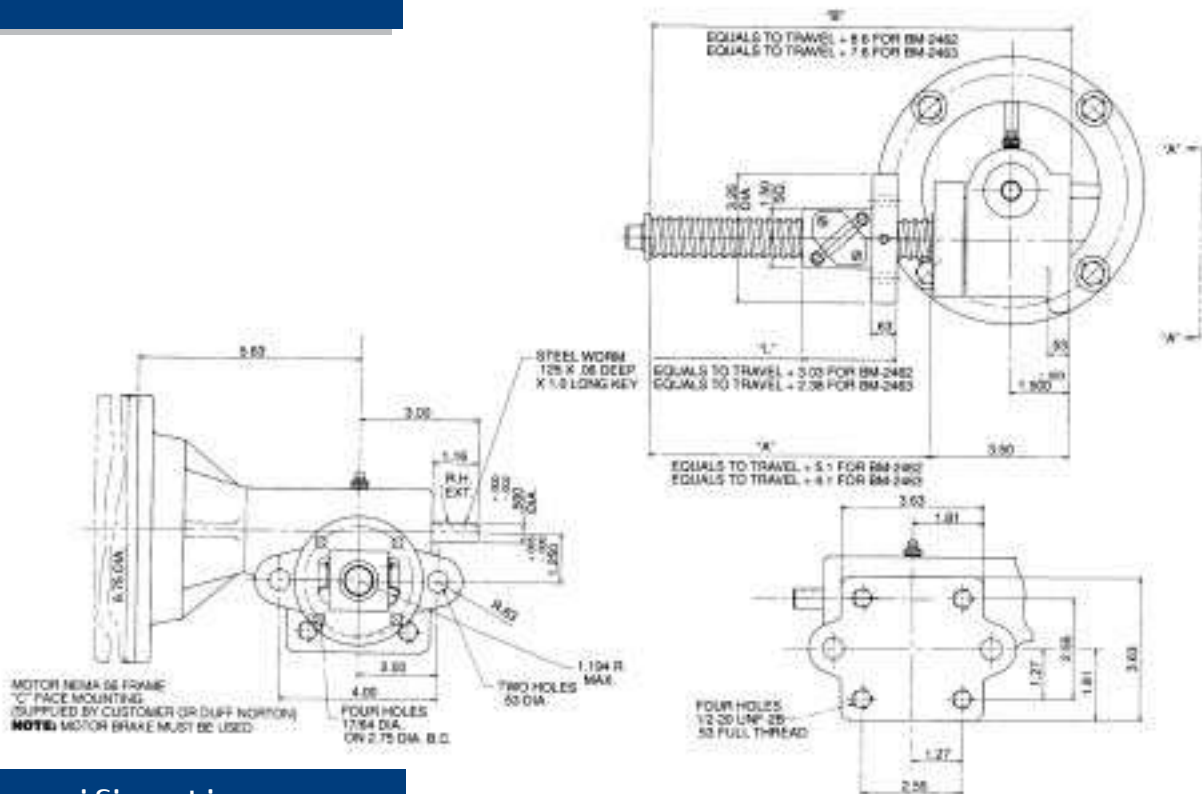

## Specifications

Model No.	"T" Lifting Screw	Turns of Worm/1" Travel				Torque lb./in. per 100 lb. Load				Motor RPM	Rated Loads (lbs.)								Lifting Speed in./min	
		Ratio		Ratio		Ratio		Ratio			Ratio		Ratio		Ratio		Ratio			
		5:1	20:1	5:1	20:1	1/4 HP Motor	1/3 HP Motor	1/2 HP Motor	3/4 HP Motor		5:1	20:1	5:1	20:1	5:1	20:1	5:1	20:1		
BM-2462	1.00 Dia. x 1.000 Lead Ball Screw	5	---	0.3	---	1725	100	---	200	---	300	---	500	---	345	---				
						1140	200	---	300	---	500	---	700	---	228	---				
BM-2463	1.0 Dia. x .250 Lead Ball Screw	20	80	1.3	0.6	1725	600	1500	900	2000	1300	---	2000	---	85	21				
						1140	1000	---	1300	---	2000	---	---	---	---	---	57	14		

- Note:
1. Model BM-2462 and BM-2463 are self-lowering and a motor brake should be used.
  2. Due to the high travel speed of BM-2462, it is important that a brake with a minimum response time be used. An independently controlled direct acting brake (6 ft/lb for 1/2 HP motors and 3 ft/lb for smaller motors) is recommended.
  3. When ordering other than 56 C-face actuators, refer to drawing and chart on page 47.

### General Features: Rotating Ball Screw and Translating Tube Ball Screw Models

- Integral 56 frame, C-face mounting flange.
- Three-piece flexible coupling for easy motor assembly (included).
- Four threaded holes in base for standard clevis end accessory attachment. Tapped 1/2 -20 UNF-2B.
- Steel worm and bronze gear set for quiet operation. Available in 5:1 and 20:1 ratios.
- Ball-bearing type heat-treated screw and mating nut with rolling contact reduces friction to a minimum providing capability for higher speed and longer life with less power requirement.
- Rugged, lightweight aluminum housing is corrosion-resistant.
- Standard grease fitting on housing for easy lubrication of worm gear.
- Stop-disc at end of lifting screw prevents inadvertent run-off of ball nut.

## Dimensions

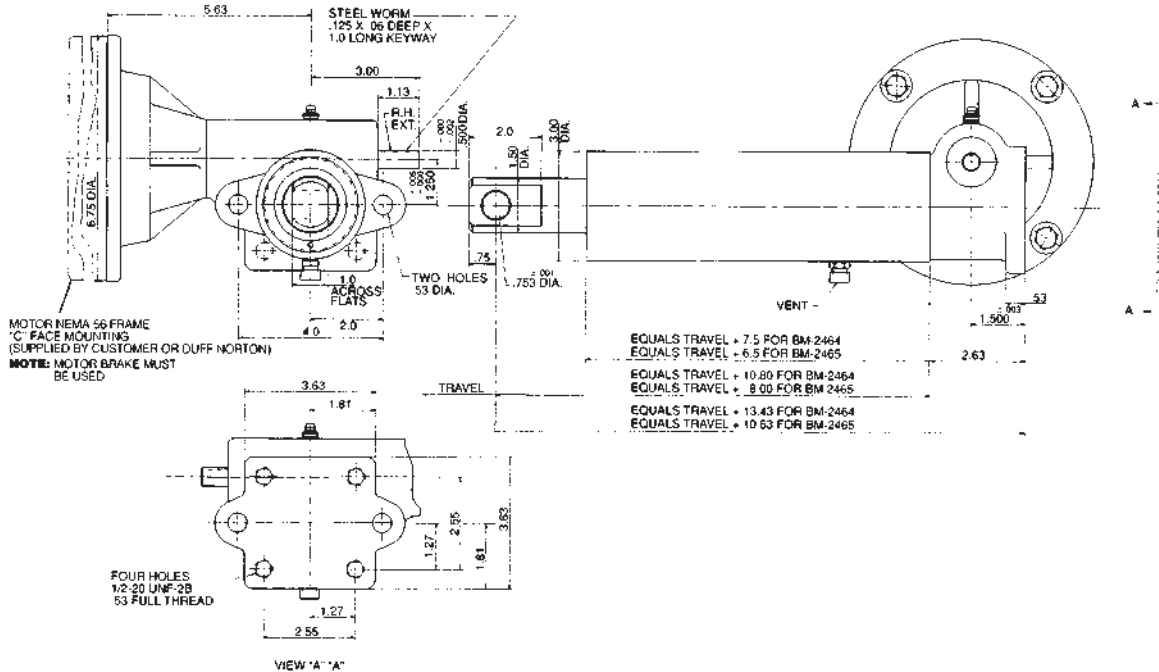

## Specifications

Model No.	"T" Lifting Screw	Turns of Worm/1" Travel		Torque lb./in. per 100 lb. Load		Motor RPM	Rated Loads (lbs.)								Lifting Speed in./min/ Ratio	
		Ratio		Ratio			1/4 HP Motor		1/3 HP Motor		1/2 HP Motor		3/4 HP Motor		Ratio	
		5:1	20:1	5:1	20:1		5:1	20:1	5:1	20:1	5:1	20:1	5:1	20:1	5:1	20:1
BM-2464	1.00 Dia. x 1.000 Lead Ball Screw	5	—	5.3	—	1725	100	—	200	—	300	—	500	—	345	—
						1140	200	—	300	—	500	—	700	—	220	—
BM-2465	1.0 Dia. x .250 Lead Ball Screw	20	80	1.3	0.6	1725	600	1500	900	2000	1300	—	2000	—	86	21
						1140	1000	—	1300	—	2000	—	—	—	57	14

- Note:
1. Model BM-2464 and BM-2465 are self-lowering and a motor brake must be used.
  2. Due to the high travel speed of BM-2464, it is important that a brake with a minimum response time be used. An independently controlled direct acting brake (6 ft/lb for 1/2 HP motors and 3 ft/lb for smaller motors) is recommended.
  3. When ordering other than 56 C-face actuators, refer to drawing and chart on page 47.

### General Features: Translating Tube Ball Screw Models

- Outer aluminum tube is corrosion-resistant and protects translating tube, lifting screw and nut.
- Wiper-scraper seal in end of outer tube keeps dirt out and lubricants in.
- Bronze guide bushing inside of outer tube reduces lateral movement of translating screw.
- Translating tube is zinc coated for weather resistance.
- Single or quadruple lead ball-bearing type lifting screw and nut for high efficiency and long life.
- Vent in outer tube prevents pressure build-up in the actuator.
- Furnished with standard clevis end. Threaded end is available; and on special order, depending on application, any type of threaded connection may be substituted.

**Model No. PS1260  
 Power Supply**

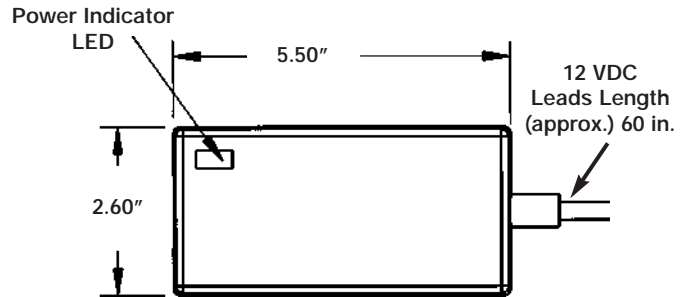

- For use with TMD01, PTD01, TMD02 and PTD02 12 VDC actuators
- Input Voltage: 115 VAC, 60 Hz
- Output Voltage: 12 VDC, 6 amps at 25% duty cycle
- ETL (C and US), CE Approved

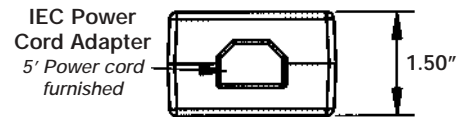



**Model No. EM1010-58**  
**Extend / Retract Control**

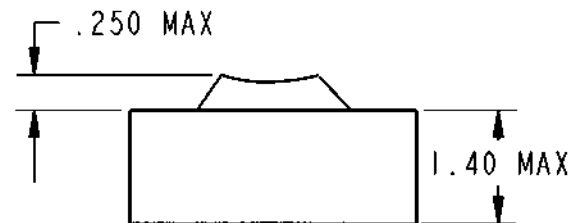
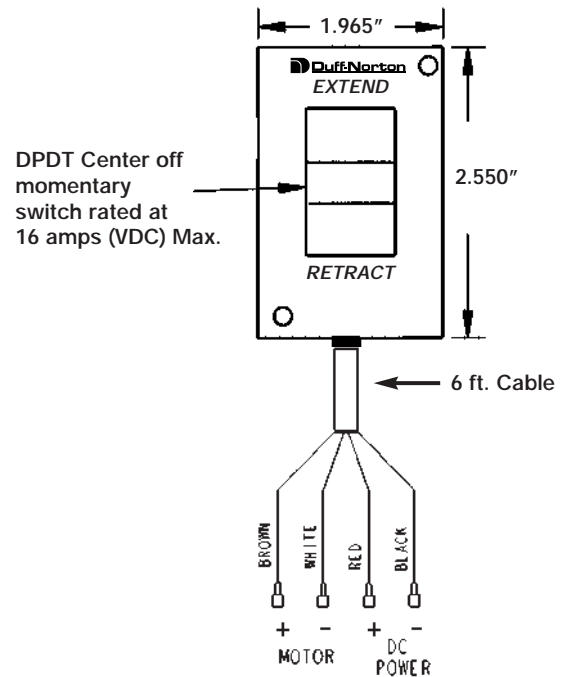

- For use with TMD01, PTD01, TMD02 and PTD02 12 VDC and 24 VDC actuators
- NEMA 1 polycarbonate enclosure
- Can be used as a handheld pendant station or surface mounted

**Model No. EM534**  
**Reversing Switch**

- Use for Forward-Off-Reverse switching of DC motors
- Switch has momentary action with spring return to Off
- Rated 15 amps max
- Has built in jumpers for easy 2-wire-in, 2-wire-out connection
- #6 screw terminals
- Use with models TMD, PTD, MPD, TAC or other actuators with direct connections to motor leads



Controls

**EMCP-1**

For TMA & TMAL 250/500 lb. Series  
 AC Units • Standard Speed



Model Number

**BAC-1C**

*115 VAC with Capacitor*

**BAC-2C**

*220 VAC with Capacitor*

**Specifications**

<b>Dimensions</b>	6 x 6 x 4 inch 152 x 152 x 102 mm	<b>Finish</b>	ANSI 61 Gray Polyester Powder Coating
<b>Enclosure</b>	NEMA 12 and 13 CSA Type 12	<b>Housing</b>	16 Gauge Steel
<b>Extend/Retract Switch</b>	Illuminated Rocker type- momentary contact with power-on indicator light	<b>Hinge</b>	Continuous
		<b>Gasket</b>	Oil Resistant
		<b>Mounting</b>	External Feet

**NOTE:**

- All Packaged Controls include a terminal strip and are internally wired and ready for connection to the power source and actuator
- All connections must be made according to the instructions accompanying each control package

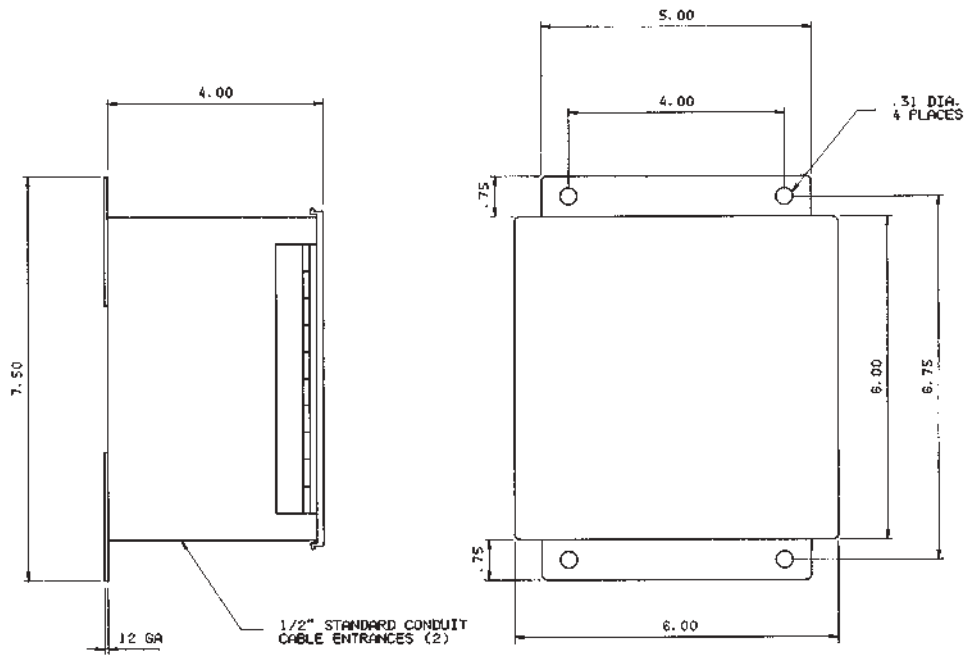

## Wiring Diagrams

### Model BAC-1C and BAC-2C

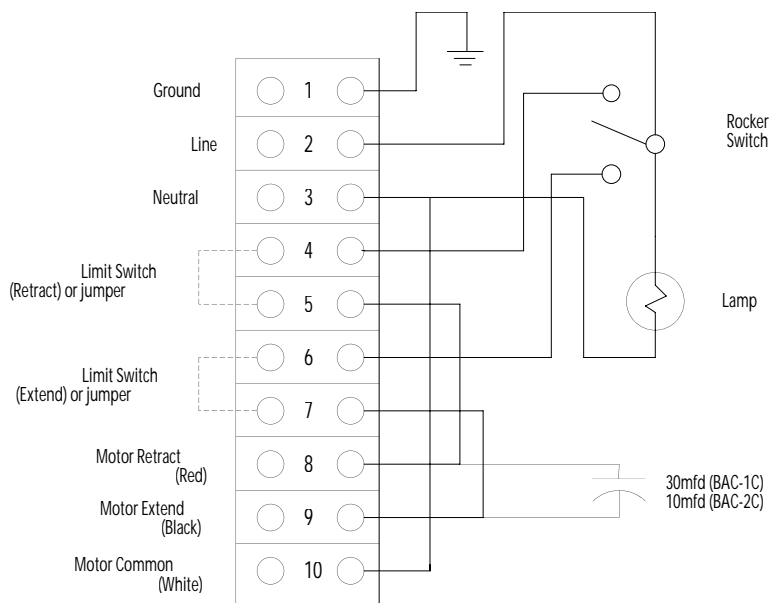



Model Number

**PAC-1CR**

*115 VAC with Capacitor and Relays*

**PAC-2CR**

*220 VAC with Capacitor and Relays*

**Specifications**

<b>Dimensions</b>	6 x 6 x 4 inch 152 x 152 x 102 mm	<b>Finish</b>	ANSI 61 Gray Polyester Powder Coating
<b>Enclosure</b>	NEMA 12 and 13 CSA Type 12	<b>Housing</b>	16 Gauge Steel
<b>Extend/Retract Switch</b>	Illuminated Rocker type- momentary contact with power-on indicator light	<b>Hinge</b>	Continuous
		<b>Gasket</b>	Oil Resistant
		<b>Mounting</b>	External Feet

**NOTE:**

- All Packaged Controls include a terminal strip and are internally wired and ready for connection to the power source and actuator
- All connections must be made according to the instructions accompanying each control package



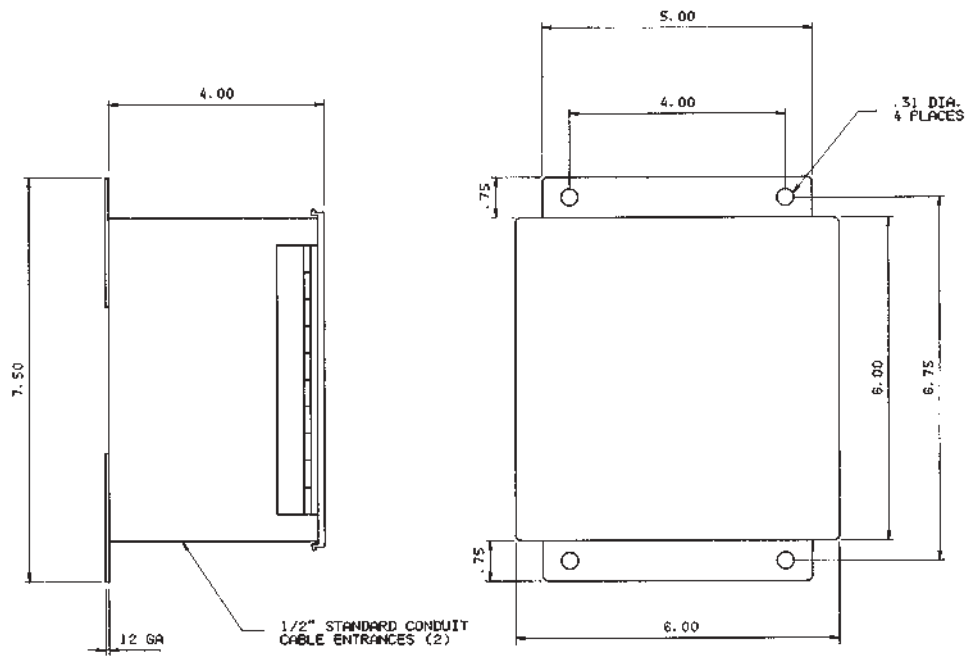

## Wiring Diagrams

### Model PAC-1CR and PAC-2CR

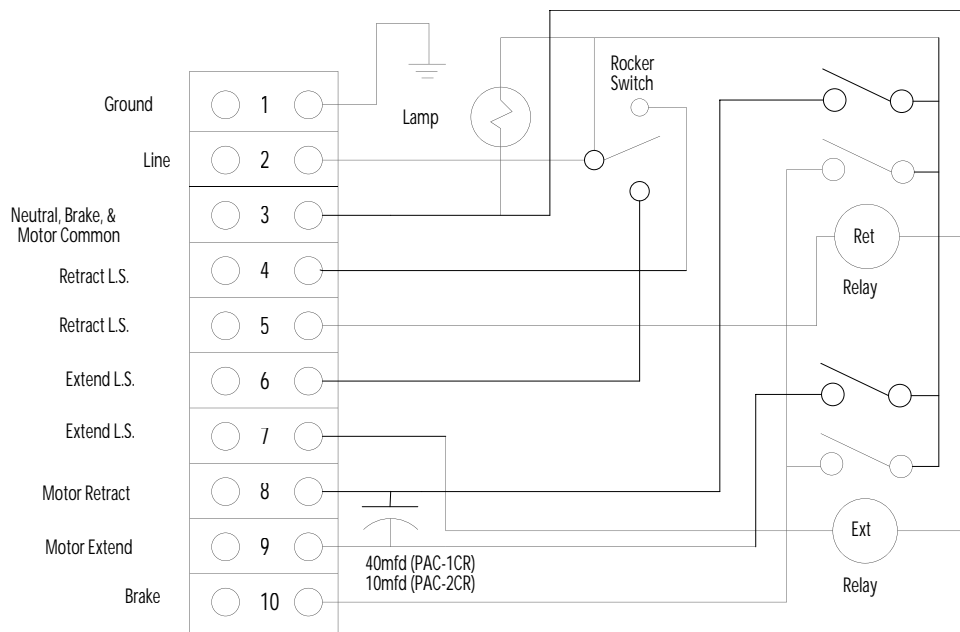



Model Number

**BAC-1**

*115 VAC*

**BAC-2**

*220 VAC*

**Specifications**

<b>Dimensions</b>	6 x 6 x 4 inch 152 x 152 x 102 mm	<b>Finish</b>	ANSI 61 Gray Polyester Powder Coating
<b>Enclosure</b>	NEMA 12 and 13 CSA Type 12	<b>Housing</b>	16 Gauge Steel
<b>Extend/Retract Switch</b>	Illuminated Rocker type- momentary contact with power-on indicator light	<b>Hinge</b>	Continuous
		<b>Gasket</b>	Oil Resistant
		<b>Mounting</b>	External Feet

**NOTE:**

- All Packaged Controls include a terminal strip and are internally wired and ready for connection to the power source and actuator
- All connections must be made according to the instructions accompanying each control package

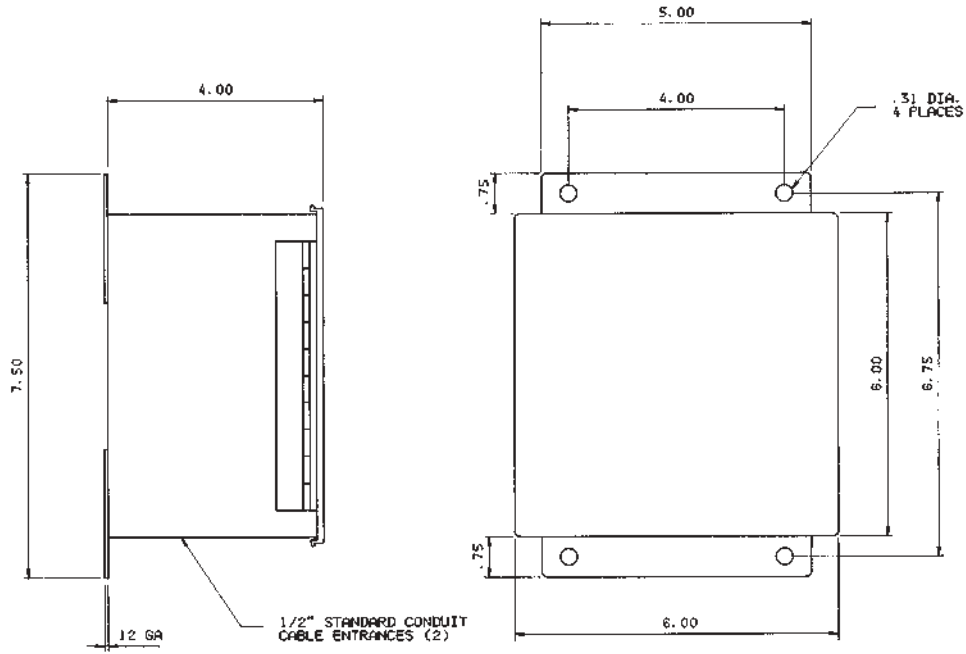

## Wiring Diagrams

### Model BAC-1 and BAC-2

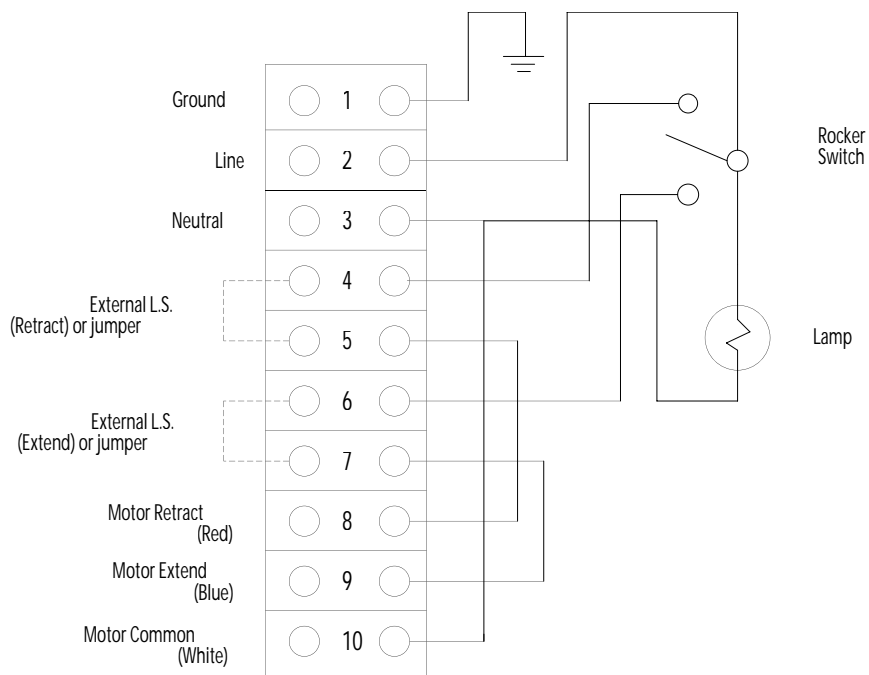



Model Number

**PDC-1R**

*12 VDC with Wired Relays*

**PDC-2R**

*24 VDC with Wired Relays*

**Specifications**

<b>Dimensions</b>	6 x 6 x 4 inch 152 x 152 x 102 mm	<b>Finish</b>	ANSI 61 Gray Polyester Powder Coating
<b>Enclosure</b>	NEMA 12 and 13 CSA Type 12	<b>Housing</b>	16 Gauge Steel
<b>Extend/Retract Switch</b>	Illuminated Rocker type- momentary contact with power-on indicator light	<b>Hinge</b>	Continuous
		<b>Gasket</b>	Oil Resistant
		<b>Mounting</b>	External Feet

**NOTE:**

- All Packaged Controls include a terminal strip and are internally wired and ready for connection to the power source and actuator
- All connections must be made according to the instructions accompanying each control package

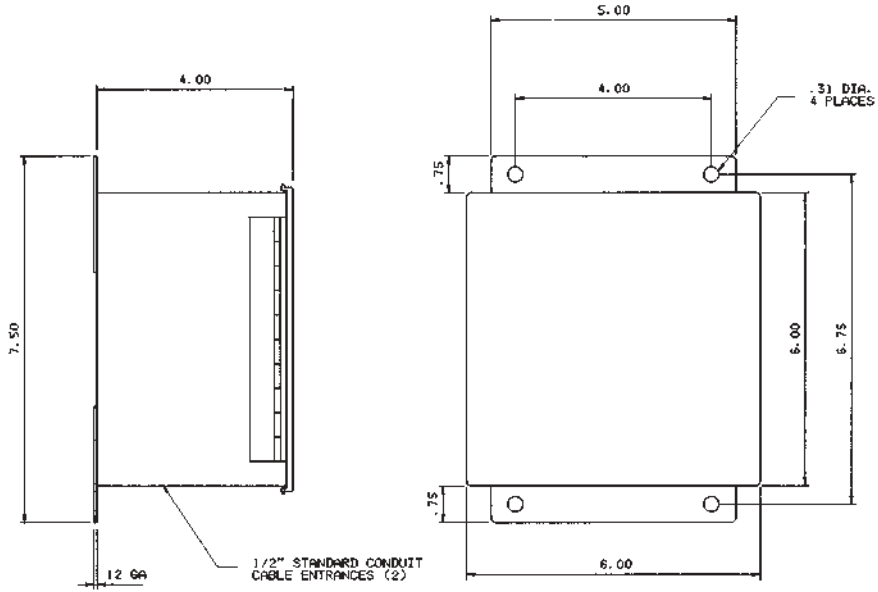

## Wiring Diagrams

### Model PDC-1R and PDC-2R

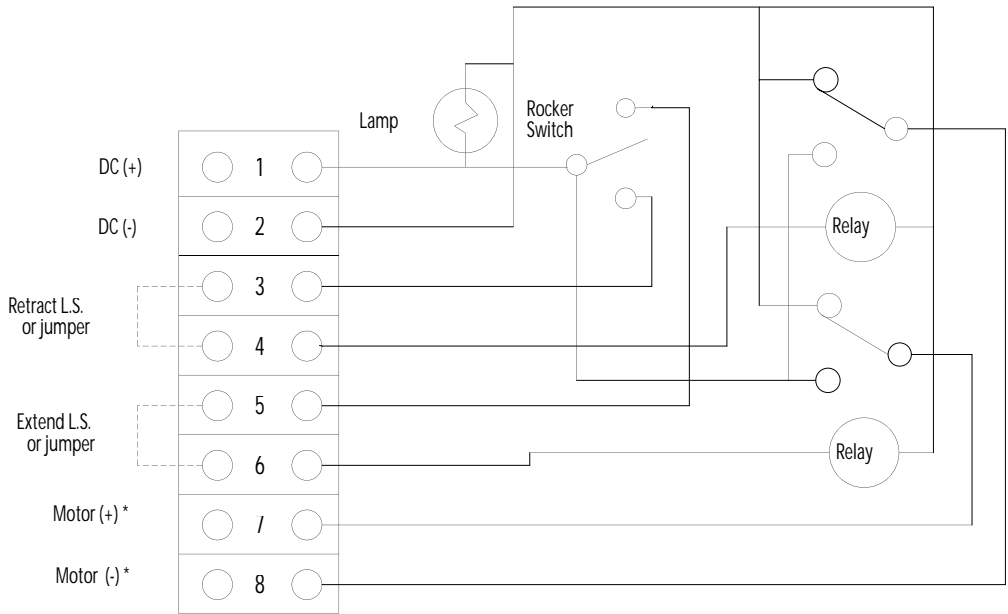

\* 250&500 Lb units: Yellow(+), Red(-)  
 1500&2000 Lb units: Orange(+), Black(-)  
 1000 Lb units: Yellow(+), Red(-). Attach brake to motor leads.

# Digital Position Indicator

Model Number

**SK6300-4K**



Digital Position Indicator

The Duff-Norton model SK6300-4K Digital Position Indicator processes a feedback signal from a 1K-ohm to 10K-ohm potentiometer to provide position readout with user selectable scaling factor. By running the actuator to two positions in its stroke and keying in the desired readout at each point, the indicator automatically scales the input signal to provide linear readout over the full travel of the actuator.

The SK6300-4K has a universal, 85-250 Vac power input and generates a regulated 24vdc excitation signal to the potentiometer. The SK6300-4K operates seamlessly with any potentiometer equipped Duff-Norton actuator.

## DIMENSIONS In Inches (mm)

Note: Recommended minimum clearance (behind the panel) for mounting clip installation is 2.1" (53.4) H x 5.0" (127) W.

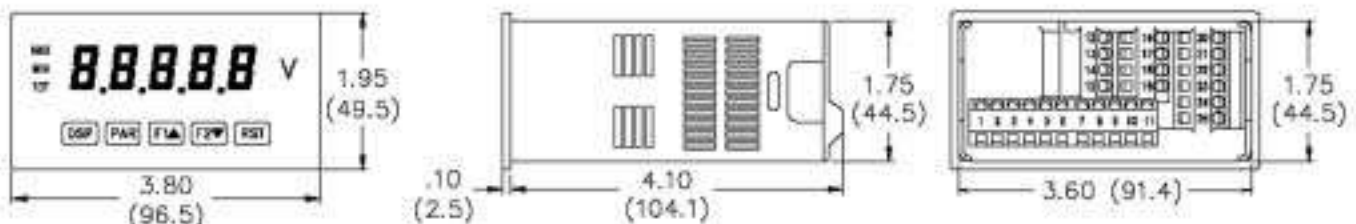



**Axial Load** - A load whose center of gravity runs through the axis of the actuator screw

**Ball Brake** - Used on smaller AC motor units, the ball brake is a bi-directional brake that limits drift when the unit is under a full load

**Cantilever Mount** - A pin mount where the pin is not supported on both sides. Deflection of the pin can cause binding. This type of mount is unacceptable

**Clevis Mount** - A flat sided fitting, or part, that is drilled to allow for mounting with a pin or bolt

**Compression Load** - A load that presses on an actuator along the axis of its screw

**Current Draw** - Amount of current (amperes) required by a motor to move a load. It increases as the load increases

**Cycle** - A complete sequence of full extension and retraction by the actuator

**Double Lead Screw** - A double lead screw has two separate threads that wrap around the outside diameter of the screw. The advantage of this type of screw is the lifting nut will travel twice the distance with each single turn of the screw

**Duty Cycle** - Percentage of time an actuator is in motion relative to total time. Example: If the total running time for an actuator is 20 seconds in every minute, the duty cycle is 33%

**Eccentric Load** - A load whose center of gravity does not go through the screw axis. Off-center loads cause binding and shorten the actuators life

**Evoloid Gear** - Evoloid gears are used to connect parallel shafts. The primary advantage over spur gearing is it allows the use of 1,2,3 or 4 tooth pinions. This has the ability to provide a large reduction in a very small package.

**Extension/Retraction Rate** - The speed at which an actuator extends and retracts. In DC models the speed can depend on the load

**Jog** - To move the actuator in short increments

**Limit Switch** - A device used to limit the extension or retraction of an actuator to a pre-set position

**Load** - Material to be moved by the actuator

**Overload Clutch** - A built-in device that slips when the actuator reaches a pre-determined load limit preventing damage to the unit

**Peak Load** - The maximum momentary load that an actuator can control

**Pivot Mount** - A clevis mount that allows the actuator to pivot while in operation

**Potentiometer** - A device that provides position feedback information from an actuator

**Screw Pitch** - The screw pitch is the distance from a point on a screw thread to the equivalent point on an adjacent thread

**Side Load** - A load exerted on the side of the actuator housing or translating tube. Side loading can shorten the life of an actuator. Also called radial load

**Spring Brake** - A bi-directional no-back type brake that is automatically activated by pinion torsion and released when the motor turns

**Spur Gear** - A gear wheel with radial teeth parallel to its axis

**Static Load** - The maximum load an actuator can hold when not operating

**Stroke Length** - The total travel of the translating tube from retracted to fully extended

**Superoid Gear** - Gears that are used to connect non-intersecting and non-parallel shafts. The worm gear is conical in shape and the gear is a face type (has gears on the face rather than the outside diameter). This type gearing allows for very high gear ratios in a compact design

**Tension Load** - A load that pulls on the actuator along the axis of its screw

**Torque Restriction** - Amount of torque exerted on the mounting brackets during operation

**Translating Tube** - The tube that extends in and out of the actuator

**Wiper Seal** - A seal between the actuator housing and the translating tube to keep contaminants out of the actuator. Also called a scraper seal

## What are the advantages of using Duff-Norton electromechanical actuators over other linear motion solutions?

Duff-Norton electromechanical actuators offer a packaged solution to your motion requirements. The integration of the actuator and motor simplifies the process of specifying and purchasing components for your motion system.

Also, Duff-Norton linear actuators offer many advantages over hydraulic cylinders when low maintenance, installation and operating costs and environmental impact are considerations.

Regardless of how simple your requirements or how complex, Duff-Norton Controls are available for all electromechanical actuators and can be customized to suit your application. In addition, Duff-Norton's application engineers can help you determine which actuator best suits your application and environment.

## Can two or more Duff-Norton electromechanical actuators be synchronized?

Tandem actuators can be used in certain applications. Small differences in motor speed may cause the actuators to get out of synchronization. Use of clutch models allows alignment when actuator is fully extended or retracted. Contact Duff-Norton application engineers to discuss your application.

## What is the difference between static load and dynamic load?

Dynamic, working, or lifting load is the force that will be applied to the actuator while it is in motion. Static load, also called holding load, is the force that will be applied to the actuator when it is not in motion.

## What's duty cycle and how is it calculated?

Duty cycle, measured in inches per hour, is the

total distance an actuator may travel (extension and retraction) in an hour with equally spaced intervals between each cycle. Duty cycle may also be expressed as a percentage, which is simply the ratio of on time to total time (on and off time).

AC actuators operate between no load and rated load with very little change in duty cycle. In DC models, duty cycle is approximately inversely proportional to load (percent of rated capacity).

## Are Duff-Norton limit switches pre-set?

Duff-Norton does not pre-set limit switches on its electromechanical actuators. Limit switches allow you the flexibility to set the limits of travel on your actuator to fit your particular application. Easy to follow instructions are included in the installation manual, and you may phone the factory if further assistance is required. The customer is responsible for properly setting the limit switch in the unit. If the limit switches are not set, or are improperly set, the unit may be damaged during operation. In addition, limit switches may require resetting if the translating tube of your actuator is rotated manually, as this will change the limit switch setting.

## What are side loading and eccentric loading, and why should they be avoided?

Side loading, or radial loading, is a force applied perpendicular to the actuator centerline. Eccentric loading is any force whose center of gravity does not act through the longitudinal axis of the actuator. Both side loading and eccentric loading should always be avoided as they can cause binding and shorten the life of the actuator.

## How is backdriving prevented in Duff-Norton electromechanical actuators?

All of Duff-Norton's electromechanical actuators include a mechanical or electrical brake to prevent the load from backdriving the actuator.

## What are the “Do’s” and “Don’ts” of mounting Duff-Norton electromechanical actuators?

Duff-Norton electromechanical actuators can be used in tension, compression, or combination applications. Eccentric and side loading should be avoided. Please consult the technical data sheets to ensure that all hardware used in conjunction with the actuator can withstand the maximum restraining torque.

## What are the most common factors in the failure of an electromechanical actuator?

Improper loading, failure to set limit switches, excessive duty and extreme environments may contribute to premature actuator failure.

## Can I adjust the speed of a Duff-Norton electromechanical actuator in the field?

Typical lifting speeds at various capacities within the operating range of each actuator are graphed on the technical data sheets. Should you have an application which requires lower speed, our application engineers can recommend another model or, if required, one that is customized for your application.

## Can Duff-Norton actuators perform complex tasks?

Yes. Complex positioning tasks can be managed through the use of position feedback devices and electronic controls.

## What does the clutch do?

The friction disk clutch in Duff-Norton electromechanical actuators is set to slip when the rated load limit of the actuator is exceeded. This is to prevent damage to the actuator due to

jamming, or overheating resulting from an excessive load. The load will be held securely should the clutch slip. The clutch also allows end of travel protection, but is not designed to be slipped repeatedly. Select a Duff-Norton actuator with internal limit switches or install external limit switches.

## Do Duff-Norton electromechanical actuators require maintenance?

Maintenance is minimal but Duff-Norton recommends periodic lubrication to maintain optimal performance. The installation and maintenance guide will give you specific instructions for your model.

## Does Duff-Norton make larger electromechanical actuators?

Duff-Norton’s electromechanical linear actuators and motor cylinders are rated for capacities up to 100 tons. Duff-Norton also offers a full line of mechanical actuators with capacities up to 250 tons and motorized actuators up to 35 tons. In addition, Duff-Norton also offers customizable controls that may be used in conjunction with any actuation system.

## How can I determine which Duff-Norton electromechanical actuator is best suited for my application?

Technical information pertaining to each model is contained in individual technical data sheets (see enclosed literature request form.) Should you require any further assistance in selecting the proper actuator for your application, please call your local stocking distributor, or Duff-Norton’s application engineering department at (800) 477-5002.

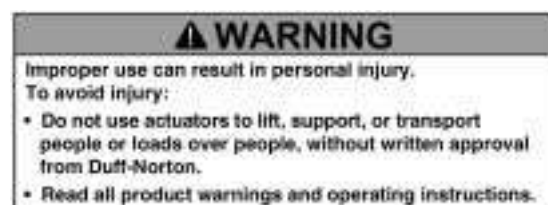

# Terms of Sale

Supersedes all previously published terms

All sales by Seller are made pursuant to the following terms. No other or additional terms or conditions are or will be accepted.

## **ACCEPTANCE OF ORDERS -**

All orders, whether placed directly or through an agent, and all subsequent amendments thereto, are subject to a final approval and acceptance by Seller's main office.

## **LIMITATION OF WARRANTIES, REMEDIES AND DAMAGES -**

THE WARRANTY STATED BELOW IS GIVEN IN PLACE OF ALL OTHER WARRANTIES, EXPRESS OR IMPLIED, OF MERCHANTABILITY, FITNESS FOR A PARTICULAR PURPOSE OR OTHERWISE. NO PROMISE OR AFFIRMATION OF FACT MADE BY ANY AGENT OR REPRESENTATIVE OF SELLER SHALL CONSTITUTE A WARRANTY BY SELLER OR GIVE RISE TO ANY LIABILITY OR OBLIGATION.

Seller warrants that on the date of its delivery to carrier the goods are free from defects in workmanship and materials.

SELLER'S SOLE OBLIGATION IN THE EVENT OF BREACH OF WARRANTY OR CONTRACT OR FOR NEGLIGENCE OR OTHERWISE WITH RESPECT TO GOODS SOLD SHALL BE EXCLUSIVELY LIMITED TO REPAIR OR REPLACEMENT, F.O.B. SELLER'S POINT OF SHIPMENT, OF ANY PARTS WHICH SELLER DETERMINES TO HAVE BEEN DEFECTIVE or if Seller determines that such repair or replacement is not feasible, to a refund of the purchase price upon return of the goods to Seller.

Any action against Seller for breach of warranty, negligence or otherwise must be commenced within one year after such cause of action accrues.

NO CLAIM AGAINST SELLER FOR ANY DEFECT IN THE GOODS SHALL BE VALID OR ENFORCEABLE UNLESS BUYER'S WRITTEN NOTICE THEREOF IS RECEIVED BY SELLER WITHIN ONE YEAR FROM THE DATE OF SHIPMENT.

Seller shall not be liable for any damage, injury or loss arising out of the use of the goods if, prior to such damage, injury or loss, such goods are (1) damaged or misused following Seller's delivery to carrier; (2) not maintained, inspected, or used in compliance with applicable law and Seller's written instructions and recommendations; or (3) installed, repaired, altered or modified without compliance with such law, instructions or recommendations.

UNDER NO CIRCUMSTANCES SHALL SELLER BE LIABLE FOR INCIDENTAL OR CONSEQUENTIAL DAMAGES AS THOSE TERMS ARE DEFINED IN SECTION 2-715 OF THE UNIFORM COMMERCIAL CODE.

## **TERMS OF PAYMENT -**

Unless otherwise stated herein, payment of each invoice is required within thirty (30) days after date of shipment. Any balance unpaid after the required payment date shall be subject to a service charge of 1% per month from such date.

## **PRICE ADJUSTMENTS -**

Amendments made by the Buyer to orders already placed shall, without formal notice to the Buyer, be subject to extra charges. If the estimated shipping date for the goods is more than sixty (60) days after date of order, the price of the goods are subject to increase by Seller.

## **TAXES -**

Any sales, use, excise, and other taxes applicable to this transaction and the goods and/or services furnished by Seller are not included in the price and shall be paid by Buyer when due. If Seller pays any such taxes, Buyer shall reimburse Seller upon demand.

## **INDEMNIFICATION AND SAFE OPERATION -**

Buyer shall comply with and require its employees to comply with directions set forth in instructions and manuals furnished by Seller and shall use and require its employees to follow such instructions and manuals and to use reasonable care in the use and maintenance of the goods. Buyer shall not remove or permit anyone to remove any warning or instruction signs on the goods. In the event of personal injury or damage to property or business arising from the use of the goods, Buyer shall, within forty-eight (48) hours thereafter, give Seller written notice of such injury or damage. Buyer shall cooperate with Seller in investigating any such injury or damage and in the defense of any claims arising therefrom.

If Buyer fails to comply with this section or if any injury or damage is caused, in whole or in part, by Buyer's failure to comply with applicable federal or state safety requirements, Buyer shall indemnify and hold Seller harmless against any claims, loss or expense for injury or damage arising from the use of the goods.

## **GOVERNING LAW -**

This agreement shall be governed by and construed under the laws of the State of New York.

## **DELIVERY AND DELAYS -**

Unless otherwise specified herein, deliveries shall be F.O.B. Seller's point of shipment and risk of loss shall pass to Buyer upon Seller's delivery to carrier. All shipping dates are approximate and Seller shall not be liable for loss or damage because of delays occasioned by labor disputes, damage to facilities, or failure of suppliers or subcontractors to meet scheduled deliveries or any other cause beyond Seller's reasonable control or making its performance commercially impracticable.

Notwithstanding other provisions hereof, if shipment is delayed at Buyer's request, the goods shall be deemed to be stored at Buyer's risk and expense and Seller may thereupon bill Buyer for the full price and storage costs. Buyer shall pay such bill within 30 days after mailing thereof.

## **BUYER'S INSPECTION UPON RECEIPT OF SHIPMENT -**

Buyer shall inspect the goods as soon as received. If any loss or damage is discovered, Buyer must notify both the carrier and Seller at once. Seller will cooperate with Buyer in filing claims with the carrier.

## **CHANGES AND CANCELLATION -**

Seller reserves the right to change or cancel any order whenever circumstances require allocation of production or delivery or Seller deems change or cancellation to be necessary to comply with applicable laws, ordinances, regulations, directives or administrative actions. Seller reserves the right to make changes in materials or design which it determines appropriate for the goods.

## **SECURITY INTEREST AND REPOSSESSION -**

Until full payment has been made therefor, Seller shall have a security interest in goods shipped to Buyer and the goods shall remain personal property. Upon request Buyer shall execute and deliver to Seller security agreements and financing statements further evidencing Seller's security interest. Buyer authorizes Seller to file a financing statement or statements relating to the goods, without Buyer's signature thereon, as Seller may deem appropriate and appoints Seller as Buyer's attorney-in-fact for the limited purpose of executing (without requiring Seller to do so) financing statements in Buyer's name and performing other acts which Seller deems appropriate to perfect and continue its security interest and to protect and preserve the goods.

In the event Buyer defaults in making any payment due Seller, Seller in addition to any other rights or remedies provided by law, shall have the right, with or without legal process, to enter the place where said goods are located and to repossess the goods in accordance with the Uniform Commercial Code.

## **ASSURANCES -**

Shipment by Seller shall at all times be subject to the prior approval of its credit personnel and Seller may, at any time, decline to make shipment except upon receipt of prior payment or upon other terms and conditions or security satisfactory to such personnel.

## **PATENTS -**

Except as to goods manufactured according to design supplied by Buyer, Seller will defend and hold Buyer free and harmless in a suit or proceeding brought against Buyer insofar as it is based on a claim that use of the goods by Buyer constitutes an infringement of any existing U.S. Patents, provided, however, that Buyer gives Seller prompt written notice of such suit or proceeding; permits Seller, through its counsel, to defend and/or settle the same; and gives Seller all necessary information, assistance and authority to enable Seller to do so. If Buyer's use of the goods is held to constitute infringement and further use is enjoined, Seller shall, at its option, either (i) procure for Buyer the right to continue using the goods; or (ii) replace the goods with non-infringing goods; or (iii) modify the goods to non-infringing goods. The foregoing states Seller's entire liability for patent infringement and shall not be construed to render Seller liable for damages based on product output.

## **MISCELLANEOUS -**

This instrument constitutes the entire agreement between Seller and Buyer, superseding all previous understandings and writings regarding this transaction. Any amendment or modification of this Agreement shall be void unless in writing and signed by Seller.

No delay or omission by Seller in exercising any right or remedy hereunder shall be a waiver thereof or of any other right or remedy, and no single or partial exercise thereof shall preclude any other or further exercise thereof or the exercise of any other right or remedy. All rights and remedies of Seller are cumulative.

Sales made pursuant to this Agreement shall be governed by the Uniform Commercial Code as the same may from time to time be construed and in effect in the state wherein Seller has its main office.

## **ARBITRATION -**

All disputes that may arise between the parties regarding the interpretation of the contract and the legal effect of the contract shall, to the exclusion of any court of law, be arbitrated and determined in accordance with the latest Commercial Arbitration Rules of the American Arbitration Association. The arbitration proceeding shall be held in the city in that state where the principal office of the Seller is located. The parties recognize and consent to the above mentioned arbitration association's jurisdiction over each and every one of them.

# Notes



Duff-Norton  
P.O. Box 7010  
Charlotte, NC 28241-1070  
Ph: 800-477-5002 • 704-588-0510  
Fax: 704-588-1994  
WebSite: [www.duffnorton.com](http://www.duffnorton.com)  
Email: [duffnorton@cmworks.com](mailto:duffnorton@cmworks.com)



EMCAT  
10M 4/05  
© Duff-Norton 2005