

EC-3000/3400 Series

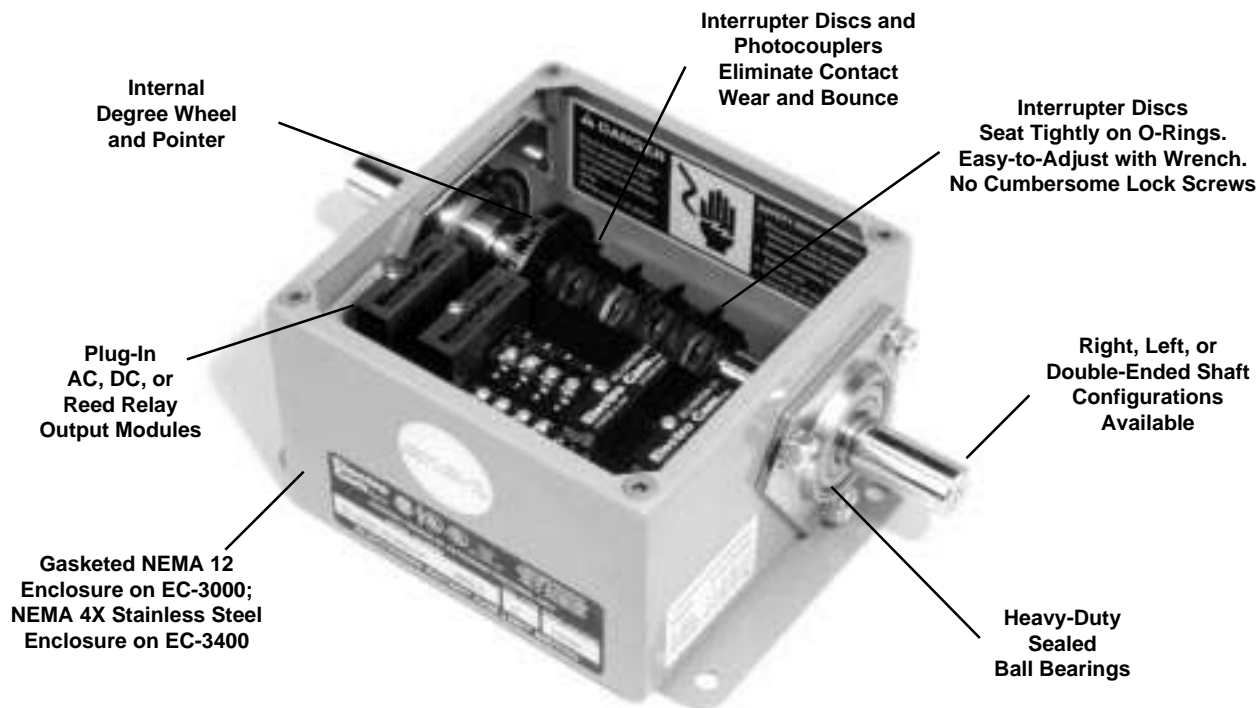

Solid State Rotary Cam Limit Switches



Description

EC-3000 Series and **EC-3400 Series** Rotary Cam Limit Switches use interrupter discs and photocouplers instead of traditional cams and mechanical limit switches, eliminating contact wear and bounce. They provide on/off control of devices such as glue guns, solenoids, air cylinders, or relays on shaft-driven machinery. Electronic Cam Limit Switches can be used as stand-alone switches, or they can be interfaced to programmable logic controllers (PLC's) or other logic circuitry.

Although generally used for applications which do not require setpoint adjustment for speed changes or product changeover, EC-3000 Series and EC-3400 Series switches can accommodate multiple setpoint schemes by assigning groups of interrupters to different product configurations. For product changeover, simply activate the appropriate group of interrupters.

Typical applications for EC-3000 Series and EC-3400 Series switches include cartoners and case packers, palletizers, gluing machines, high-speed presses, automatic assembly, pick and place equipment, and similar machinery.

Features

- Available with 4, 8, or 12 fused, optically-isolated outputs.
- Heavy-duty construction for industrial environments.
- Plug-in modules for AC or DC outputs; replaceable input/output fuses, easily removed and installed with a needle nose pliers.
- LED's indicate output status.
- EC-3000 units housed in NEMA 12 enclosures; EC-3400 units housed in NEMA 4X stainless steel enclosures.
- Sealed ball bearings.
- Internal degree wheel and pointer located on shaft for easy and accurate adjustment.
- Right, left, or double-ended shaft extensions with a #606 Woodruff key provision; double-ended stainless steel shaft standard with NEMA 4X models.
- Available options include multi-pulse discs, external degree wheel and pointer, sprocket disengagement clutch, high-vibration models, and special shafts.
- Standard EC-3000 and EC-3400 UL listed, CSA certified; 240 VAC models not UL listed.

Theory of Operation

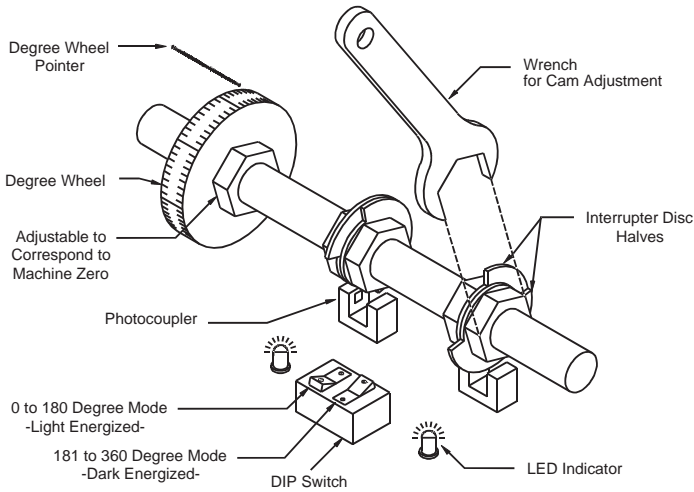

Figure 1

As shown in Figure 1, each output switch is controlled by two-part interrupter discs which break the beam of light in a photocoupler. If the DIP switch associated with a photocoupler is in the “0° to 180°,” or Light Energized mode, the output will be switched on when the beam is unbroken. If the DIP switch is in the “181° to 360°,” or Dark Energized mode, the output will be switched on when the interrupter breaks the beam.

The gap, or open window in the interrupter is adjusted by using a wrench to turn the disc halves. Shown below in Figure 2 is a chart showing a few examples of setting “on” times, by adjusting the gap and the DIP switch positions.

Disc halves seat tightly to the shaft with O-rings. The discs are easy to adjust with a wrench, requiring no cumbersome locking screws or other devices.

SWITCH MODE	ENERGIZED BY	ON TIME	EXAMPLE CAM SETTINGS			
0° - 180° Light Energized	Photocopler Light Beam -PASSING-	Fully Adjustable 1° to 180°	From 0° to 170° ON for 170°	From 45° to 180° ON for 135°	From 90° to 135° ON for 45°	From 312° to 322° ON for 7°
181° - 360° Dark Energized	Photocopler Light Beam -BLOCKED-	Fully Adjustable 181° to 359°	From 170° to 0° ON for 190°	From 180° to 45° ON for 225°	From 135° to 90° ON for 315°	From 322° to 315° ON for 353°

Figure 2

†SINKING or SOURCING (as pertaining to Electro Cam Corp. products)

Sinking means that when the logic is true and the output (or input device) is ON, the output (or input device) is providing a DC common or ground to the connected device.

Sourcing means that when the logic is true and the output (or input device) is ON, the output (or input device) is providing a +DC voltage to the connected device.

This information is important when interfacing an Electro Cam Corp. product with another electronic device. The terms **SINKING / SOURCING** are not used in the same context by all manufacturers. If you are using an Electro Cam Corp. product input to an Allen-Bradley 1746-IN16 “sinking” input card* or similar A-B device, you have to supply a +DC voltage to this card, NOT a DC common or ground. In these cases, **Sinking** is what the card does with the input voltage; sinks it to common or ground.

* Other manufacturers include, but not limited to: Koyo (formerly GE Series 1, Texas Instruments, or Siemens SIMATIC PLS’s) that use descriptions similar to Allen-Bradley.

Standard Models

All EC-3000 Series units are housed in NEMA 12 enclosures. All EC-3400 Series units are housed in NEMA 4X stainless steel enclosures. All units have either right, left, or double-ended shaft extensions with a #606 Woodruff Key provision; Nema 4X models have a double-ended stainless steel shaft. The cover plate on the EC-3400 Series units is secured with clamps to avoid contamination.

Five standard EC-3000 Series and four standard EC-3400 Series models are available:

Model	Outputs	Standard Shafts*
EC-3004/EC-3404	4	Right, left, or double
EC-3008/EC-3408	8	Right, left, or double
EC-3012/EC-3412	12	Right, left, or double

*See dimensional drawings for shaft illustrations. Special shafts can be supplied. Please enclose shaft drawing and specs with your order. All NEMA 4X units are ONLY available in double-ended shafts.



Model EC-3004-10-ARO

Options

Pulse Generating Discs

Multi-output pulse generating discs are an option offered for applications requiring multiple outputs per revolution. These discs are most often used to generate timing pulses for tachometers, motion detection, glue stitching, or wherever multi-pulse signals are required. Glue stitching patterns on carton and case sealing equipment is an example of an application that benefits from pulse generating discs. Standard pulse discs are available with 1, 2, 3, 4, 6, 7, 10, 16, 20, 32, 60, and 64 slots per revolution, allowing for quick changeover. Pulse generating discs must be ordered with the unit. The discs are factory mounted on the cam shaft, and each disc replaces one set of adjustable cams. See Publication 107B for more detailed information.

Sprocket Disengagement Clutch

The sprocket disengagement clutch is essential in situations where the shaft needs to be easily disconnected from the sprocket without removing the chain. The clutch not only allows for disengagement of one station of the machine to check operation without jogging the entire machine, but it simplifies the adjustment of the rotary cam limit switch. The clutch automatically locks back in the home position after one revolution. The clutch has a 3/4 inch bore with the provision for a #606 Woodruff key. There are five standard and numerous special sprockets available. See Publication 108B for more detailed information.

External Degree Wheel and Pointer

An internal degree wheel and pointer is included with each EC-3000 and EC-3400 unit for reference during cam adjustment. To visually determine shaft position without removing the cover, an optional external degree wheel and pointer is available. This option must be ordered with the unit, and requires a double-ended shaft for mounting. Specify mounting on left- or right-hand shaft (see mounting dimensions), and clockwise or counterclockwise rotation as viewed from end of shaft.

CFX for High Shock / Vibration

For extremely high shock or vibration, such as punch press applications, a CFX option may be needed on the EC-3000 or EC-3400 units. The CFX option adds clear conformal coating on both sides of the printed circuit board and removable jumpers replace the DIP switch. The jumpers eliminate the possibility of intermittent connection to the DIP switch or the accidental changing of the DIP switch setting through shock or vibration.

CF for Highly Contaminating Environments

For highly contaminating environments, the CF option may be ordered with the EC-3000 units. The CF option adds clear conformal coating to both sides of the printed circuit board. This option is standard on all EC-3400 units.

Mounting and Shaft Connection

The shaft can be coupled to the machine using a chain and sprocket, timing pulley and belt, or a direct in-line shaft-to-shaft coupling.

If a shaft-to-shaft coupling is used, Electro Cam Corp. recommends the use of a flexible coupling. Flexible couplings available through Electro Cam Corp. are listed on the Rotary Cam Switch Price List, Lit. #111.



CAUTION

Using a solid coupling with shaft misalignment greater than 0.005" (T.I.R.) may damage the unit. Because of tolerance stackups, this will require shimming of the individual unit to its mounting surface.

Specifications

Max Speed:	3000 RPM, clockwise or counterclockwise rotation		
Max Phase Shift:	1°/1000 RPM		
Ambient Temp:	0° to 60°C (32° to 140°F)		
Input Voltage:	120 VAC (108 to 132 VAC), 50 or 60 Hz. 12 VDC, 24 VDC or 240 VAC units available		
Input Power:	EC-3004/EC-3404	3 VA Max	
	EC-3008/EC-3408	6 VA Max	
	EC-3012/EC-3412	6 VA Max	
Shaft:	3/4" diameter shaft extensions. The shaft is rated at 32,000 PSI yield and necked down to 0.500" internally. Power transmission through shaft should be based on these figures.		
Max Side Load:	100 lbs. at speeds up to 1800 RPM / 200 lbs. at speeds up to 500 RPM		
Bearing Life:	10 years (87,660 hours) continuous running with 75 lbs. side load at 1000 RPM Note: Consult factory if higher speeds or larger loads are required.		
Enclosures:	EC-3000—NEMA 12 steel housing EC-3400—NEMA 4X stainless steel housing		
Printed Circuit Board:	EC-3000—conformal coating on top only EC-3400—conformal coating on top and bottom		
Net Weight:	EC-3004/EC-3404:	9.0 lbs.	4.0 kg
	EC-3008/EC-3408:	13.5 lbs.	6.1 kg
	EC-3012/EC-3412:	15.0 lbs.	6.8 kg

Output Module Specifications

The EC-3000 Series and the EC-3400 Series units offer plug-in modules for DC, AC, and Reed Relay outputs. **One output module must be purchased for each output desired.** For further information, please consult the factory.

DC Output:	EC-ODC5, Red	AC Outputs:	EC-OAC5A-11, Black/Gray
Output Voltage:	0 to 60 VDC	Output Voltage:	24 to 132 VAC
Output Current:	1.0 Amp @ 35°C (95°F) Derate 35.7 mA/°C above 35°C (95°F)	Output Current:	0.8 Amp @ 35°C (95°F) Derate 50 mA/°C above 35°C (95°F)
DC Output:	EC-ODC5A, Red	Reed Relay:	EC-ORR5, White
Output Voltage:	0 to 200 VDC	Output Type:	Reed Relay Contacts
Output Current:	0.5 Amp Derate .018 amp/°C above 45°C (113°F)	DC Rating:	0 to 24 VDC 0 to 100 mA DC (resistive loads only)
		AC Rating:	0 to 120 VAC 0 to 30 mA AC (resistive loads only)

Terminal and Component Identification

The following three drawings are component layouts.

EC-3400 Series Units

All EC-3400 Series units have the same component layout as the EC-3000 Series units except a stainless steel double-ended shaft extension and stainless steel enclosure with clamps to secure the cover are standard.

Figure 3
EC-3004 Unit

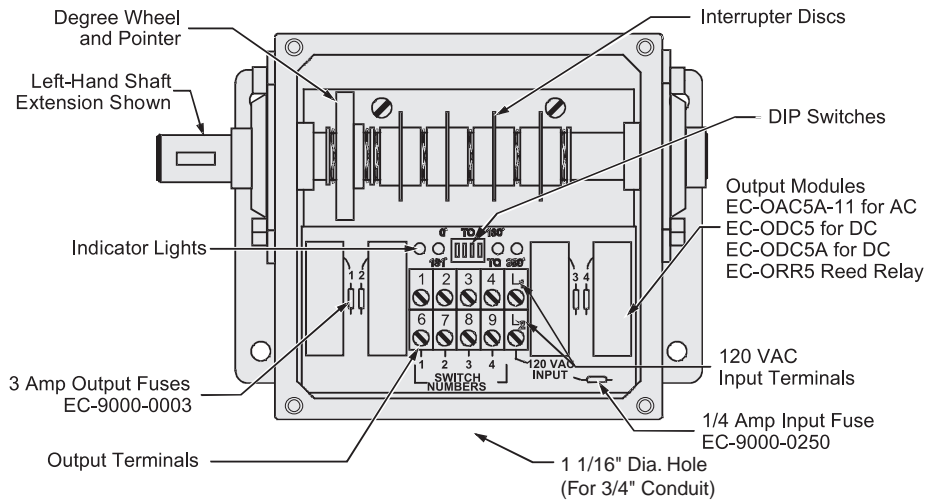

Figure 4
EC-3008 Unit

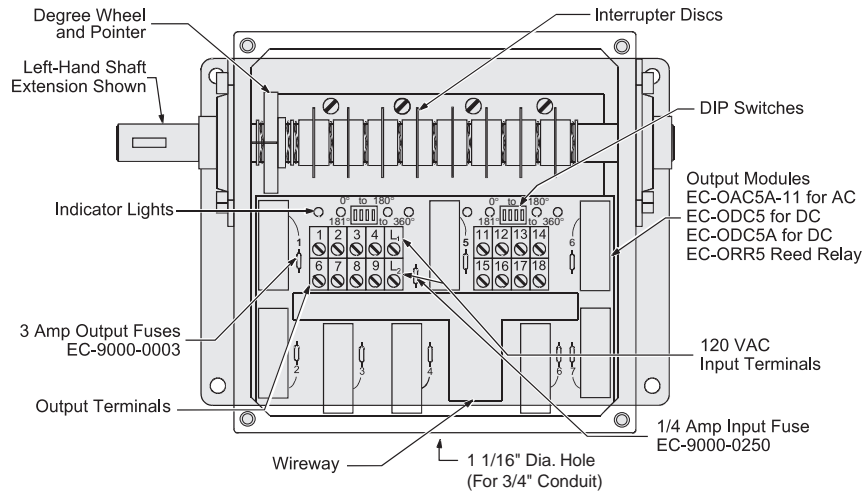
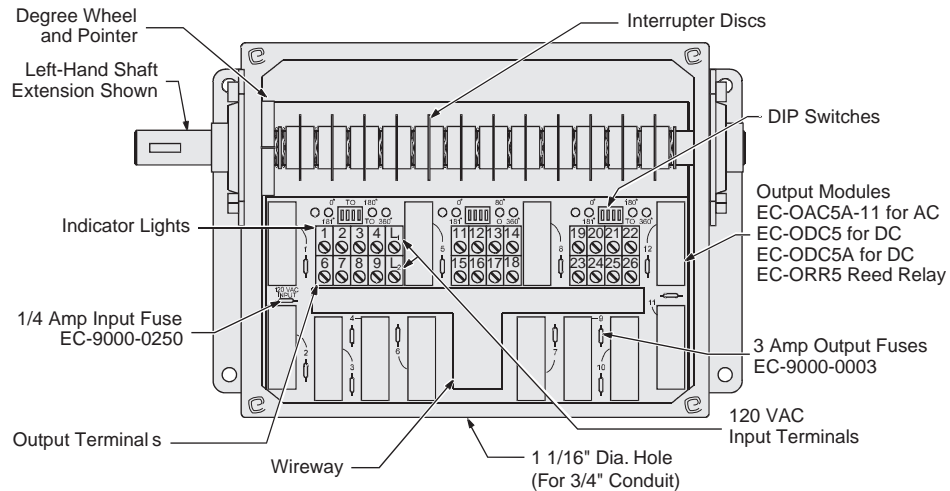

Figure 5
EC-3012 Unit



Mounting Dimensions - EC-3004, EC-3008 & EC-3012

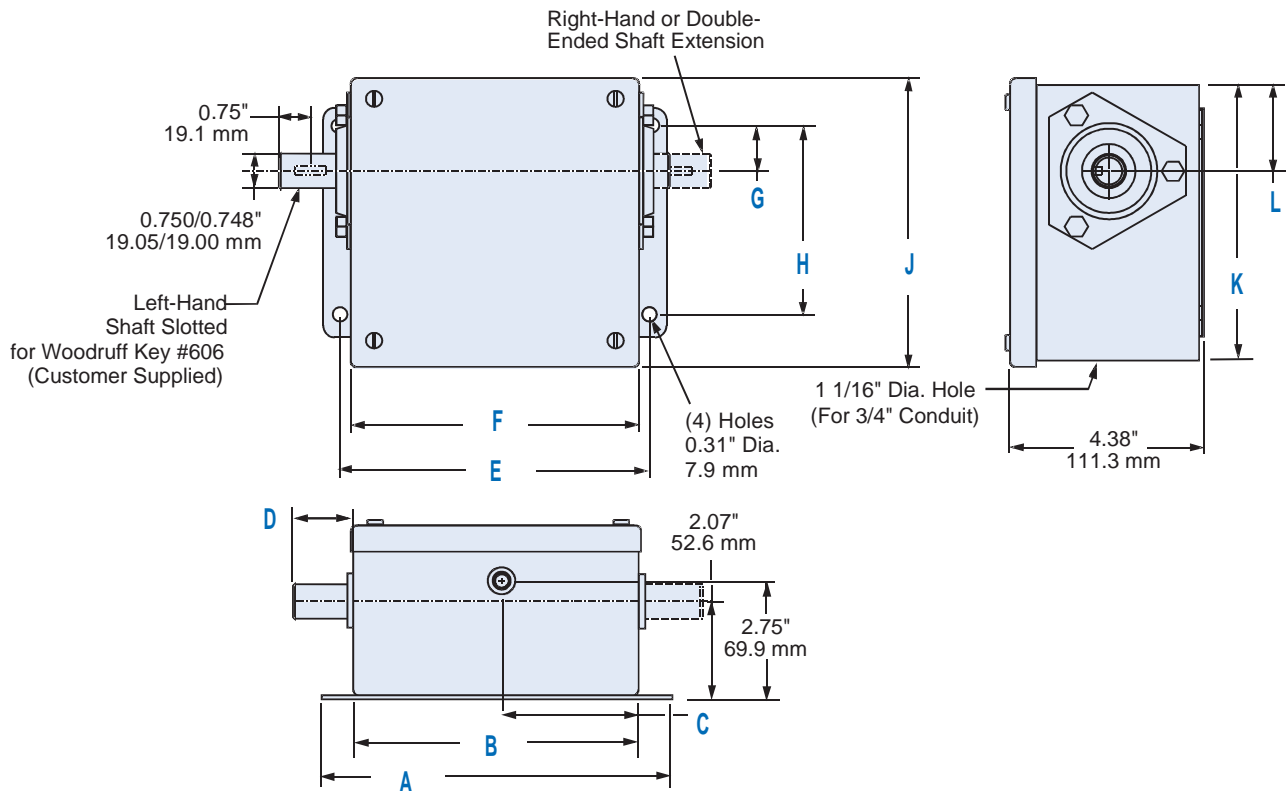

Figure 6
EC-3004, EC-3008 & EC-3012

	EC-3004	EC-3008	EC-3012
A	7.50" (190.5 mm)	9.50" (241.3 mm)	11.50" (292.1 mm)
B	6.00" (152.4 mm)	8.00" (203.2 mm)	10.00" (254.0 mm)
C	3.00" (76.2 mm)	3.38" (85.9 mm)	5.00" (127.0 mm)
D	1.94" (49.3 mm)	2.50" (63.5 mm)	2.50" (63.5 mm)
E	6.75" (171.5 mm)	8.75" (222.3 mm)	10.75" (273.1 mm)
F	6.25" (158.8 mm)	8.25" (209.6 mm)	10.25" (260.4 mm)
G	0.88" (22.4 mm)	1.25" (31.8 mm)	1.25" (31.8 mm)
H	4.00" (101.6 mm)	6.00" (152.4 mm)	6.00" (152.4 mm)
J	6.25" (158.8 mm)	8.25" (209.6 mm)	8.25" (209.6 mm)
K	6.00" (152.4 mm)	8.00" (203.2 mm)	8.00" (203.2 mm)
L	1.88" (47.8 mm)	2.25" (57.2 mm)	2.25" (57.2 mm)

Table 1
EC-3004, EC-3008 and EC-3012 Dimensions

Mounting Dimensions - NEMA 4X Units

Figure 7
EC-3404

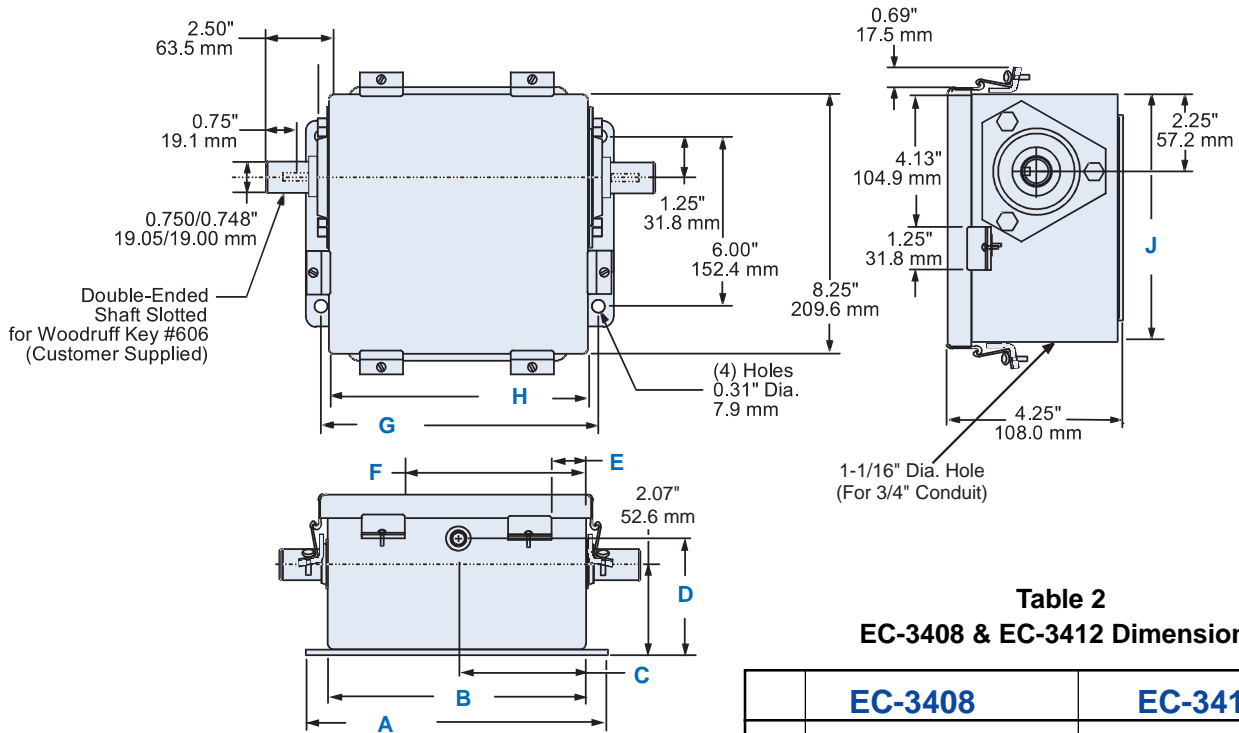
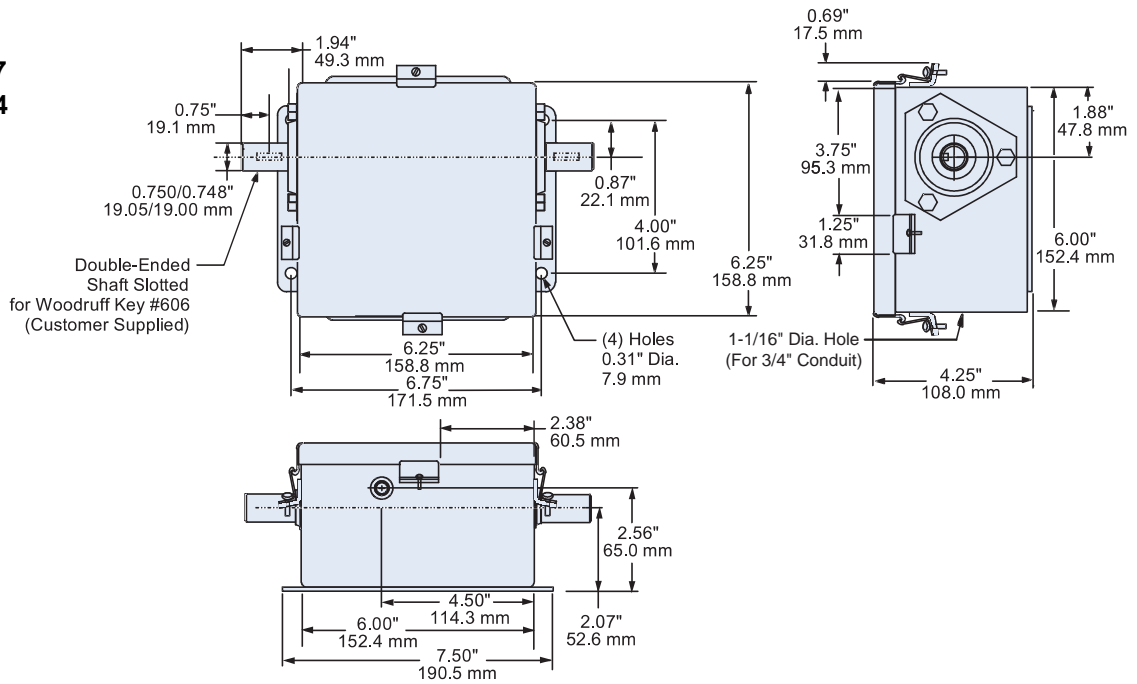

Figure 8
EC-3408 & EC-3412

Table 2
EC-3408 & EC-3412 Dimensions

	EC-3408	EC-3412
A	9.50" (241.3 mm)	11.50" (292.1 mm)
B	8.00" (203.2 mm)	10.00" (254.0 mm)
C	3.38" (85.9 mm)	5.00" (127.00 mm)
D	2.56" (65.0 mm)	2.75" (69.9 mm)
E	1.00" (25.4 mm)	1.50" (38.1 mm)
F	5.25" (133.4 mm)	7.25" (184.2 mm)
G	8.75" (222.3 mm)	10.75" (273.1 mm)
H	8.25" (209.6 mm)	10.25" (260.4 mm)
J	8.00" (203.2 mm)	10.00" (254.0 mm)

Input Wiring

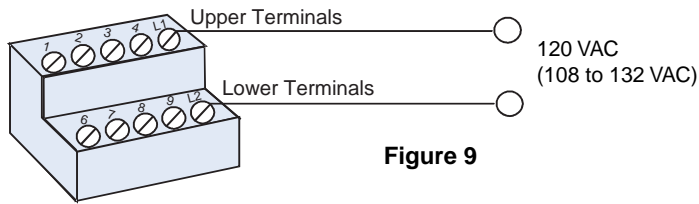

Figure 9

The terminal block shown is for an EC-3004 unit or EC-3404 unit. Other models will contain more blocks.

Output Module Wiring

Output modules act like switches; they do not supply power to loads.

Output modules available for the EC-3000 and EC-3400 Series units include DC, AC, and Reed Relay. An output module is required for each output being used. Refer to page 4 for further module information. Module signals are isolated from one another, allowing AC and DC modules to be mixed on the same control.

DC Output Module Wiring

DC output modules can be wired to sink[†] or source[†] load circuit.

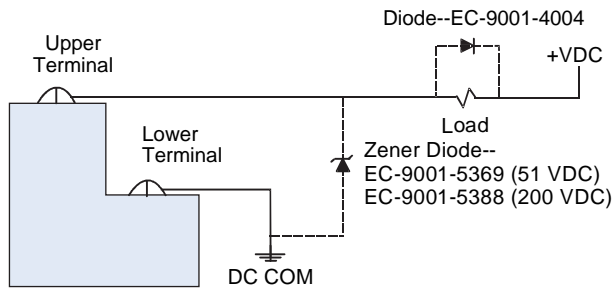

Figure 10 - Sinking[†] Output

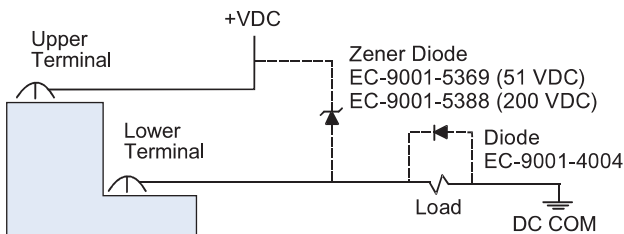

Figure 11 - Sourcing[†] Output

Most applications will function properly without the diodes shown in the wiring diagrams above. However, highly inductive DC loads may damage modules by generating voltage spikes when switched off. This type of inductive load may need to be suppressed by a diode. If necessary, use one of the following two methods to incorporate a diode into your circuit.

- Connect a Zener diode across the terminals. This will not significantly increase the load turn-off time. The voltage rating of the diode must be greater than the normal circuit voltage.
- Connect a reverse-biased diode across the load. This may increase the load turn-off time.

[†] See page 2 for sinking/sourcing definitions.

AC Output Module Wiring

AC output modules are wired with the load connected to the lower terminal of the output module, while the external power supply is connected to the upper terminal.

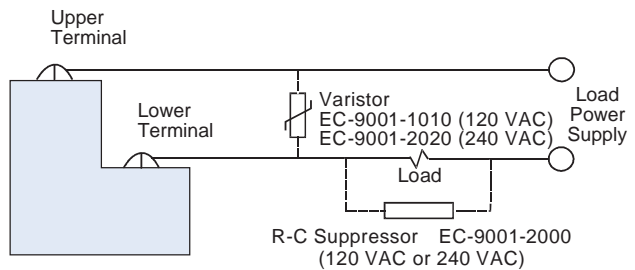

Figure 12

Most applications will function properly without the varistor or R-C suppressor shown in the wiring diagram above. However, when other switching devices are in series or parallel with the AC output module, voltage spikes may damage the module. If necessary, use one of the following two methods to suppress voltage spikes.

- For infrequent switching, connect a varistor (MOV) across the terminals.
- For continuous switching, connect an R-C suppressor in parallel with the load.

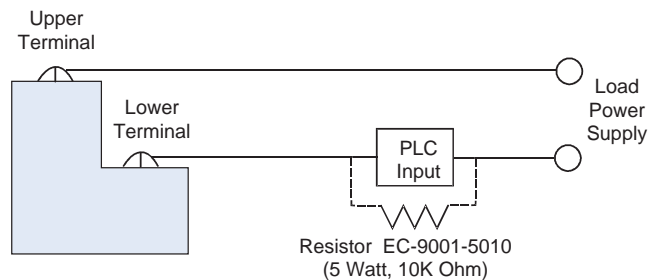

Figure 13

Most applications will function properly without the resistor shown in the wiring diagram above. However, it may be necessary to add the resistor if the load is affected by the module's off-state leakage of 2 mA maximum. Keep in mind that a resistor across a PLC input card may speed up the response time of that PLC input.