

Gas and Air Cocks

Model PB80

Description

These gas and air cocks are designed with the following features:

- Large ports to minimize pressure drop and turbulence.
- Teflon seats, stern packing seal, and thrust washer to assure long life.
- Bottom loaded, pressure-retaining stem of rugged construction.
- Adjustable stern gland screw for added wear.
- Self-cleaning chrome-plated brass ball for erosion resistance and durability.
- Fast, quarter-turn operation.
- Non-heat vinyl grip on cadmium plated steel handle.
- Can be installed with flow in either direction.

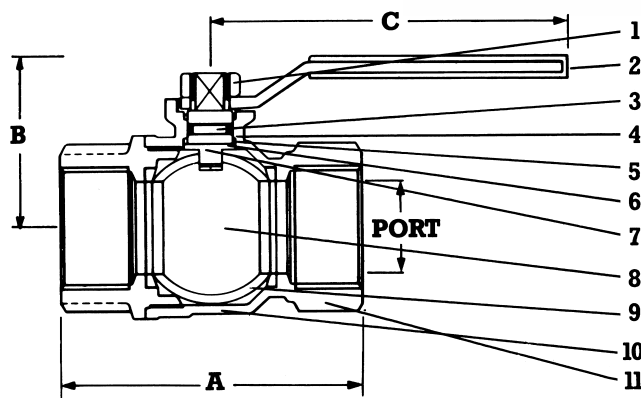

Dimensions

DP No.	Size	Port	A	B	C
111701	1/4"	0.3149	1.6929	1.1023	1.6535
111702	3/8"	0.3937	1.9409	1.2913	3.0708
111703	1/2"	0.5905	2.3503	1.4212	3.0708
111704	3/4"	0.7874	2.6850	1.8661	3.7795
111705	1"	0.9842	3.2047	2.0236	3.7795
111706	1-1/4"	1.2598	3.7401	2.2204	3.7795
111707	1-1/2"	1.5748	4.0905	2.7795	5.4330
111708	2"	1.9685	4.9566	3.0748	5.4330

Materials Specification

Item	Name	Material
1	Handle Nut	Cadmium Plated Steel
2	Handle (Vinyl Insulated)	Cadmium Plated Steel
3	Packing Gland	Brass
4	Stem Packing	P.T.F.E.*
5	Thrust Washer	P.T.F.E.*
6	Stem O-Ring	Nitrile Rubber
7	Stem	Hard Chromium Plated Brass
8	Ball	Hard Chromium Plated Brass
9	Seats	P.T.F.E.*
10	Body	Forged Brass
11	End Adapter	Forged Brass

P.T.F.E.* is Polytetrafluoroethylene (Teflon)

Approvals



(1/2" & 1/4" sizes)
1/2" & 3/4" Tested to
ANSI/ASME B16.33



Conforms to Fed.
Spec WW-V-35B

Gas and Air Cocks

AC929A2

Model PGB1020

Description

- Compact design for ease of installation.
- Smooth, fast quarter-turn operation.
- Corrosion resistant chrome-plated ball is self-cleaning.
- Forged construction.

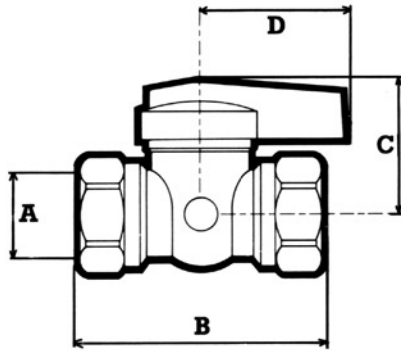

Dimensions

DP No.	A	B	C	D
111715	1/2"	2.364	1.277	1.411
111716	3/4"	2.60	1.422	1.379

Materials Specification

Name	Material
Fixing Screw	Brass
"T" Handle	Aluminum
Lever Handle	Aluminum
Fixing Ring	Phosphor Bronze
Head Washer	Brass
Bonnet	Brass
'O' Ring Seal	Special Rubber to ASTM D471
Secondary Seals	Compressed Fiber
Ball	Hard Chromium Plated Forged Brass
Seat	Special Rubber to ASTM D471
Body	Forged Brass

Approvals

