



Price Index



10 Widths
7 Bending Radii



Smooth interior for long cable life

Tapered insertion point for easy assembly

Snap-open, hinged to left or right, along the inner or the outer radius, accessible from the top, rather than from the side, of the link

3 options for interior separation



5 options for mounting brackets



Various strain relief options



Extender crossbar for large diameter hoses



Click Here for Specs & CAD Files



When to use the Series 340/350:

- If snap-open accessibility along inner or outer radius is required
- If integrated strain relief is required at the connection point
- If modular interior separation is required
- If cables up to $\varnothing 1.65"$ (42 mm) diameter are involved
- Travel up to 492 ft (150 m)
- Long service life

- Accessories for
 - ▶ Guide Troughs, Chapter 9
- Further information
 - ▶ Design, Chapter 1



When not to use the Series 340/350:

- If maximum stability is required
 - ▶ System E4, Series 380, Chapter 6
- If each link requires snap-open accessibility on both sides simultaneously
 - ▶ System E4, Series 380, Chapter 6
- If chip protection is required
 - ▶ Energy Tube E2, Series R68, R167/R168, Chapter 5
- If the application is very simple
 - ▶ E-Z Chain, Series E/Z 300, Chapter 2



Large pins for long service life

Dirt-repellent exterior

Lateral glide surfaces for side-mounted operation

Double stop dog for strong unsupported length

Integrated strain relief possible

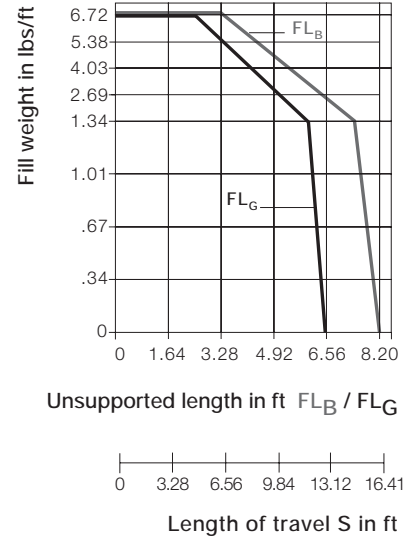

Unsupported length

- FL_B = unsupported with permitted sag
- FL_G = unsupported with straight upper run

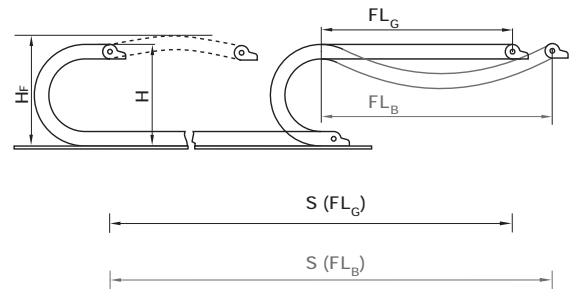

Unsupported Energy Chains® ▶ **Design, Chapter 1**, feature positive camber over short travels. This must be accounted for when specifying the clearance height. Please refer to **Installation dimensions** for further details.

If the unsupported length is exceeded, the Energy Chain®/Tube must glide on itself. This requires a guide trough ▶ **Design, Chapter 1** or incorporation of igus® exclusive AUTO-GLIDE System guide elements, which are available for this chain series ▶ **AUTO-GLIDE System, Chapter 9**.

Other Installation Methods:

Vertical, hanging	= max 262 ft (80 m)
Vertical, standing	= max 9.84 ft (3 m)
Side-mounted, unsupported	= max 3.28 ft (1 m)
Rotary	= requires further calculation

● Long travel Max: 492 ft (150 m)

Series 340/350 E2 "medium"



340
350

Series 340 Energy Chain®

(snap-open along inner radius)

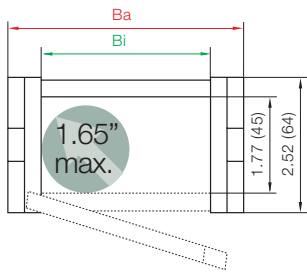

Part No.	Bi	Ba
340-050	1.97 (50)	2.76 (70)
340-075	2.95 (75)	3.74 (95)
340-100	3.94 (100)	4.72 (120)
340-115	4.53 (115)	5.31 (135)
340-125	4.92 (125)	5.71 (145)
340-150	5.91 (150)	6.69 (170)
340-175	6.89 (175)	7.68 (195)
340-200	7.87 (200)	8.66 (220)
340-225	8.86 (225)	9.65 (245)
340-250	9.84 (250)	10.63 (270)

Bending Radii
for ALL Widths
2.95 (075)
3.94 (100)
4.92 (125)
5.91 (150)
7.87 (200)
9.84 (250)
11.81 (300)

Supplement part no. with required radius
for example, 340-050-150-0

Series 350 Energy Chain®

(snap-open along outer radius)

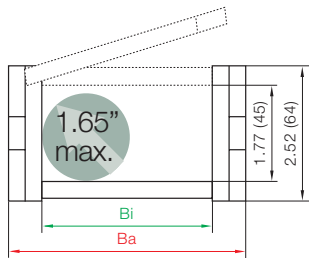

Part No.	Bi	Ba
350-050	1.97 (50)	2.76 (70)
350-075	2.95 (75)	3.74 (95)
350-100	3.94 (100)	4.72 (120)
350-115	4.53 (115)	5.31 (135)
350-125	4.92 (125)	5.71 (145)
350-150	5.91 (150)	6.69 (170)
350-175	6.89 (175)	7.68 (195)
350-200	7.87 (200)	8.66 (220)
350-225	8.86 (225)	9.65 (245)
350-250	9.84 (250)	10.63 (270)

Bending Radii
for ALL Widths
2.95 (075)
3.94 (100)
4.92 (125)
5.91 (150)
7.87 (200)
9.84 (250)
11.81 (300)

Supplement part no. with required radius
for example, 350-050-150-0

! Use Series 350 for gliding applications)

Installation Dimensions

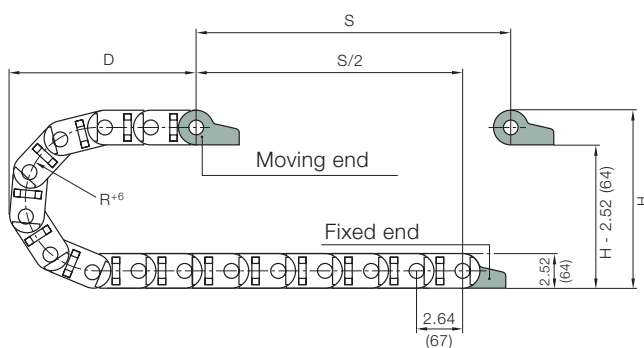

R	2.95 (075)	3.94 (100)	4.92 (125)	5.91 (150)
H*) ⁺⁵ ₀	8.46 (215)	10.43 (265)	12.40 (315)	14.37 (365)
D	5.91 (150)	7.87 (200)	8.86 (225)	9.84 (250)
K	15.75 (400)	19.69 (500)	25.59 (650)	28.54 (725)

R	7.87 (200)	9.84 (250)	11.81 (300)
H*) ⁺⁵ ₀	18.31 (465)	22.24 (565)	26.18 (665)
D	11.81 (300)	13.78 (350)	15.75 (400)
K	34.45 (875)	41.34 (1050)	48.23 (1225)

*The required clearance height is HF = H + 1.57 (40 mm) with 1.68 (2.5 kg/m) fill weight. Please consult igus® if space is particularly restricted.

Pitch: = 2.64 (67 mm) per link
Links per ft (m): = 4.57 (15)
Chain length: = $\frac{S}{2} + K$



PDF: www.igus.com/echainpdf.asp
Specs/CAD/RFO: www.igus.com/echain.asp
RoHS info: www.igus.com/RoHS.asp



Extender crossbar

The extender crossbars were developed specifically for applications in which a large diameter hose must be guided carefully. It is intended for hoses with a maximum outer diameter of 4.53 (115 mm). The extender crossbar can be placed along either the outer (Series 350) or inner (Series 340) radius. In most applications, the inner radius is preferred. However, the chain cannot glide on itself in this case. If gliding operation is required, the crossbars are assembled along the outer radius and a special guide trough is required. The extender crossbar can either be attached to the side links directly or can be used in combination with two standard snap-open crossbars.

If the extender crossbars are attached along the outer radius, the side of the chain must be supported so that the crossbars do not come in contact with the running surface. We are happy to assist with the design and assembly of this type of system. This design is also suitable for gliding applications. We are also happy to assist with guide trough requirements.

Extender crossbar: Series 340



340-150...

340-175...

Series	max. Hose Ø in. (mm)	Bending Radii in. (mm)
340-150	3.54 (90)	5.91 (150), 7.87 (200), 9.84 (250)
340-175	4.53 (115)	7.87 (200), 9.84 (250)

Extender crossbar: Series 350



350-150...

350-175...

Series	max. Hose Ø in. (mm)	Bending Radii in. (mm)
350-150	3.54 (90)	2.95 (75), 3.94 (100), 4.92 (125), 5.91 (150), 7.87 (200), 9.84 (250)
350-175	4.53 (115)	2.95 (75), 3.94 (100), 4.92 (125), 5.91 (150), 7.87 (200), 9.84 (250)

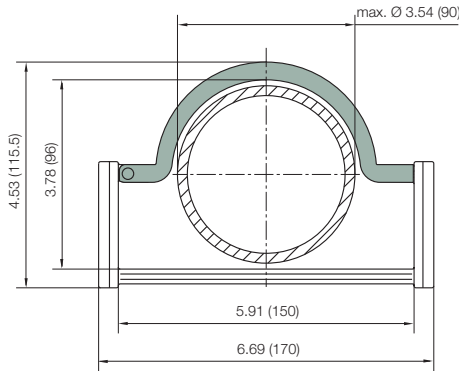

Part No. (round extender crossbar)
3500-150-D090

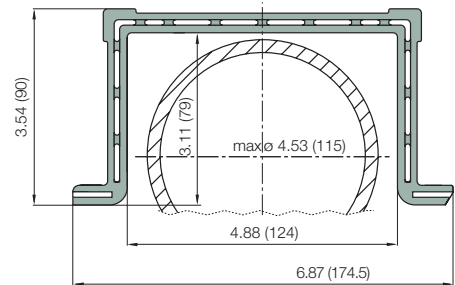

Part No. (square extender crossbar)
3500-175-D115*

*This product also available in round design - order Part No. 3500-175-RD115

Order Example

1. Chain selection:
350-150-D090-175-0

- Color black
- Radius
- Crossbar inside Ø
- Width
- Chain type

2. Mounting brackets:
3150-34-PZB

- With tiwrap plates
- Full set, pivoting
- Chain width

3. Assembly:

As with all Series 340/350 crossbars, the extender crossbars are opened using a screwdriver.

For 16.4 ft (5 m) chain, color black, with pivoting mounting brackets
16.4 ft (5 m) 350-150-D090-175-0 and 3150-34PZ

75 links — 4.57 links/ft (15 links/m)



Interior Separation

Option 1: vertical separators

Separators are used when vertical compartmentalization of the Energy Chain® is the only type of separation required. Spacers can be used on either side of each separator to maintain the distance between them. Spacers are necessary primarily with side-mounted chains.

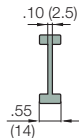
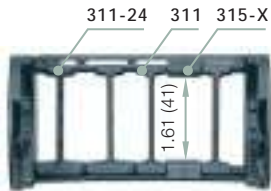

Vertical Separator

Unassembled	Part No. 301
Assembled	Part No. 311



Spacer

Unassembled	Part No. 305-08
Assembled	Part No. 315-08



Spacer

Unassembled	Part No. 305-12
Assembled	Part No. 315-12

Option 2: full-width shelf

Full-width shelves are used with applications involving numerous thin cables with similar or identical diameters. This shelf slides into place and spans the entire width of the chain.

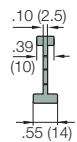
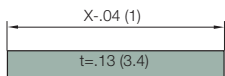
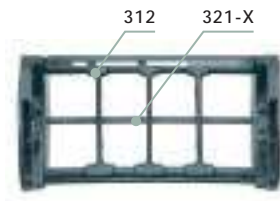

Vertical Separator, Slotted

Unassembled	Part No. 302
Assembled	Part No. 312

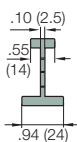

Vertical Separator, Slotted

Unassembled	Part No. 302-24
Assembled	Part No. 312-24

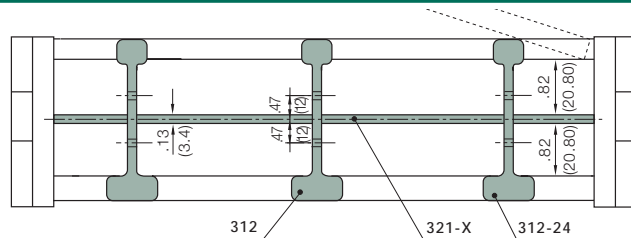

Width X in. (mm)	Part No.	
	Unassembled	Assembled
1.97 (50)	320-050	321-050
2.95 (75)	320-075	321-075
3.94 (100)	320-100	321-100
4.53 (115)	320-115	321-115
4.92 (125)	320-125	321-125
5.91 (150)	320-150	321-150
6.89 (175)	320-175	321-175
7.87 (200)	320-200	321-200
8.86 (225)	320-225	321-225
9.84 (250)	320-250	321-250

Option 3: shelves

This option is used most often in applications with numerous cables possessing different diameters. It allows for variable compartment heights and widths across the chain width, but can also be used for level separation across the entire inner width. Option 3 shelves can be combined with Option 1 separators and side plates.

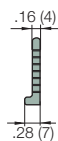
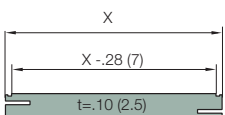
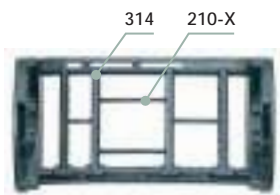

Side Plate

Unassembled	Part No. 303
Assembled	Part No. 313

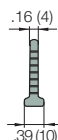

Vertical Separator, Slotted

Unassembled	Part No. 304
Assembled	Part No. 314

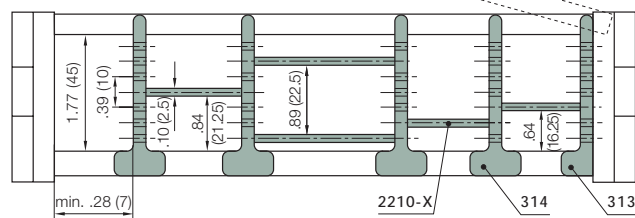

Width X in. (mm)	Part No.	
	Unassembled	Assembled
.71 (18)	2200-18	2210-18
.91 (23)	2200-23	2210-23
1.10 (28)	2200-28	2210-28
1.30 (33)	2200-33	2210-33
1.50 (38)	2200-38	2210-38
1.69 (43)	2200-43	2210-43
1.89 (48)	2200-48	2210-48
2.28 (58)	2200-58	2210-58
2.68 (68)	2200-68	2210-68
2.87 (73)	2200-73	2210-73
3.46 (88)	2200-88	2210-88
3.90 (99)	2200-99	2210-99
4.88 (124)	2200-124	2210-124

PDF: www.igus.com/echainpdf.asp
 Specs/CAD/RFQ: www.igus.com/echain.asp
 RoHS info: www.igus.com/RoHS.asp



Mounting Brackets

Option 1: pivoting

- Pivoting
- Short and long travels
- Space-restricted conditions
- Corrosion-resistant

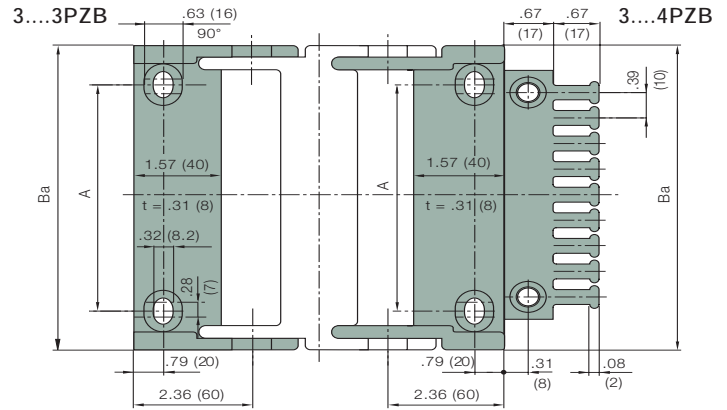
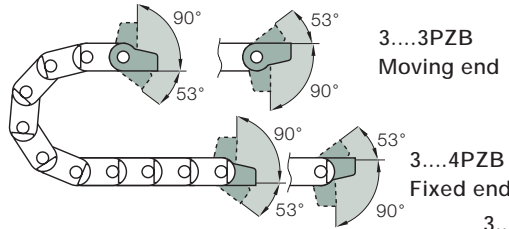

- 3...34 PZB = Full set, each part with pin/bore, including tiewrap plates
- 3...3 PZB = Mounting bracket with bore, including tiewrap plates
- 3...4 PZB = Mounting bracket with pin, including tiewrap plates

Chain Type	Part No. Full Set with Tiewrap Plates	Part No. Set with Tiewrap Plates and 10 Cable Tiewraps	Part No. Mounting Bracket Set	Dimension A in. (mm)
340/350-050	3050-34PZB	3050-34PZBK1	3050-34PZ	1.10 (28)
340/350-075	3075-34PZB	3075-34PZBK1	3075-34PZ	2.09 (53)
340/350-100	3100-34PZB	3100-34PZBK1	3100-34PZ	3.07 (78)
340/350-115	3115-34PZB	3115-34PZBK1	3115-34PZ	3.66 (93)
340/350-125	3125-34PZB	3125-34PZBK1	3125-34PZ	4.06 (103)
340/350-150	3150-34PZB	3150-34PZBK1	3150-34PZ	5.04 (128)
340/350-175	3175-34PZB	3175-34PZBK1	3175-34PZ	6.02 (153)
340/350-200	3200-34PZB	3200-34PZBK1	3200-34PZ	7.01 (178)
340/350-225	3225-34PZB	3225-34PZBK1	3225-34PZ	7.99 (203)
340/350-250	3250-34PZB	3250-34PZBK1	3250-34PZ	8.98 (228)

Option 2: locking

- Locked connections
- Vertical hanging/standing travels
- Extreme accelerations
- Corrosion-resistant

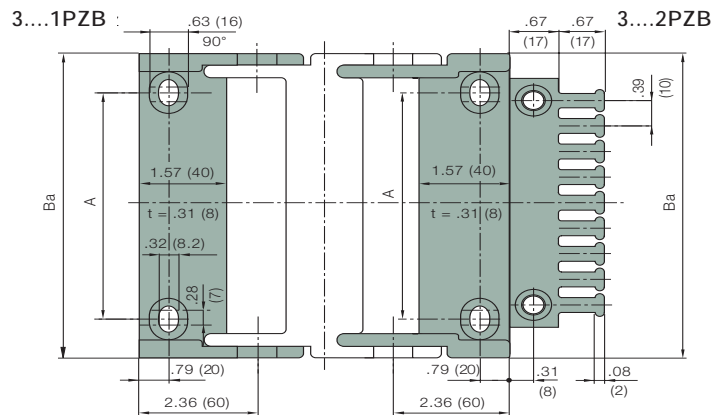
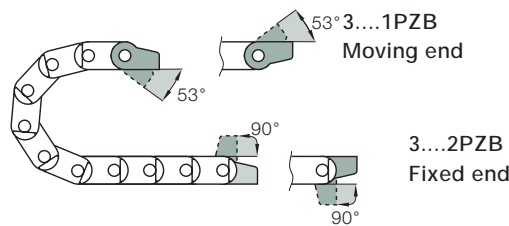

- 3...12 PZB = Full set, each part with pin/bore, including tiewrap plates
- 3...1 PZB = Mounting bracket with bore, including tiewrap plates
- 3...2 PZB = Mounting bracket with pin, including tiewrap plates

Chain Type	Part No. Full Set with Tiewrap Plates	Part No. Set with Tiewrap Plates and 10 Cable Tiewraps	Part No. Mounting Bracket Set	Dimension A in. (mm)
340/350-050	3050-12PZB	3050-12PZBK1	3050-12PZ	1.10 (28)
340/350-075	3075-12PZB	3075-12PZBK1	3075-12PZ	2.09 (53)
340/350-100	3100-12PZB	3100-12PZBK1	3100-12PZ	3.07 (78)
340/350-115	3115-12PZB	3115-12PZBK1	3115-12PZ	3.66 (93)
340/350-125	3125-12PZB	3125-12PZBK1	3125-12PZ	4.06 (103)
340/350-150	3150-12PZB	3150-12PZBK1	3150-12PZ	5.04 (128)
340/350-175	3175-12PZB	3175-12PZBK1	3175-12PZ	6.02 (153)
340/350-200	3200-12PZB	3200-12PZBK1	3200-12PZ	7.01 (178)
340/350-225	3225-12PZB	3225-12PZBK1	3225-12PZ	7.99 (203)
340/350-250	3250-12PZB	3250-12PZBK1	3250-12PZ	8.98 (228)

igus® Energy Chain Systems®

Telephone 1-800-521-2747
Fax 1-401-438-7270

Internet: <http://www.igus.com>
email: sales@igus.com
QuickSpec: <http://www.igus.com/qs/echain.asp>

Series 340/350 E2 "medium" Mounting Brackets



340
350

Option 3: KMA pivoting

- Pivoting
- Short and long travels
- Optional integrated profile rail for strain relief
- Bolted connection outside of chain cross section
- Space-restricted conditions
- Corrosion-resistant
- Universal use

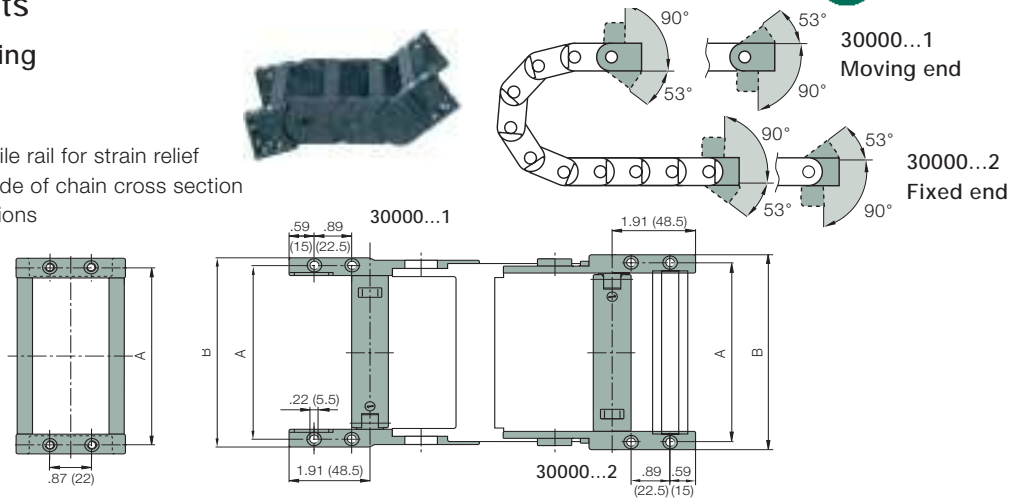

Chain Type	Part No. Full Set with Profile Rail	Part No. Set Mounting Brackets	Dimension A in. (mm)	Dimension B in. (mm)
340/350-050	30000-050-12P	30000-050-12	2.48 (63)	2.91 (74)
340/350-075	30000-075-12P	30000-075-12	3.46 (88)	3.90 (99)
340/350-100	30000-100-12P	30000-100-12	4.45 (113)	4.88 (124)
340/350-115	30000-115-12P	30000-115-12	5.04 (128)	5.47 (139)
340/350-125	30000-125-12P	30000-125-12	5.43 (138)	5.87 (149)
340/350-150	30000-150-12P	30000-150-12	6.42 (163)	6.85 (174)
340/350-175	30000-175-12P	30000-175-12	7.40 (188)	7.83 (199)
340/350-200	30000-200-12P	30000-200-12	8.39 (213)	8.82 (224)
340/350-225	30000-225-12P	30000-225-12	9.37 (238)	9.80 (249)
340/350-250	30000-250-12P	30000-250-12	10.35 (263)	10.79 (274)



30...12 = Full set, each part with pin/bore
 30...1 = Mounting bracket with bore
 30...2 = Mounting bracket with pin

Option 4: KMA locking

- Locked connections
- Short and long travels
- Optional integrated profile rail for strain relief
- Bolted connection outside of chain cross section
- Space-restricted conditions
- Corrosion-resistant
- Universal use

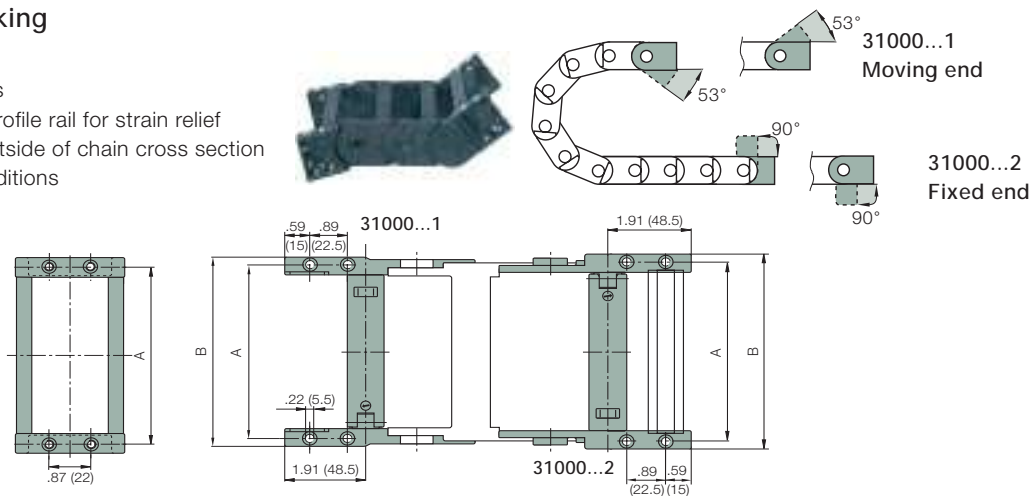

Chain Type	Part No. Full Set with Profile Rail	Part No. Set Mounting Brackets	Dimension A in. (mm)	Dimension B in. (mm)
340/350-050	31000-050-12P	31000-050-12	2.48 (63)	2.91 (74)
340/350-075	31000-075-12P	31000-075-12	3.46 (88)	3.90 (99)
340/350-100	31000-100-12P	31000-100-12	4.45 (113)	4.88 (124)
340/350-115	31000-115-12P	31000-115-12	5.04 (128)	5.47 (139)
340/350-125	31000-125-12P	31000-125-12	5.43 (138)	5.87 (149)
340/350-150	31000-150-12P	31000-150-12	6.42 (163)	6.85 (174)
340/350-175	31000-175-12P	31000-175-12	7.40 (188)	7.83 (199)
340/350-200	31000-200-12P	31000-200-12	8.39 (213)	8.82 (224)
340/350-225	31000-225-12P	31000-225-12	9.37 (238)	9.80 (249)
340/350-250	31000-250-12P	31000-250-12	10.35 (263)	10.79 (274)

31...12 = Full set, each part with pin/bore
 31...1 = Mounting bracket with bore
 31...2 = Mounting bracket with pin

PDF: www.igus.com/echainpdf.asp
 Specs/CAD/RFO: www.igus.com/echain.asp
 RoHS info: www.igus.com/RoHS.asp

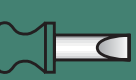

Mounting Brackets

Option 5: Steel

- One part for all chain widths
- Electrically conductive

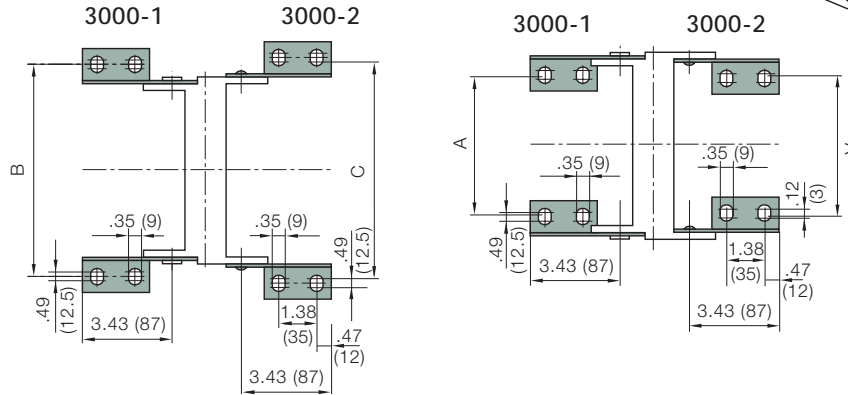
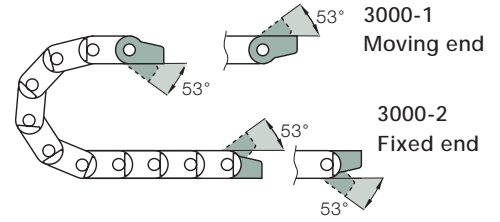

Chain Type	Part No. Full Set	Dimension A in. (mm)	Dimension B in. (mm)	Dimension C in. (mm)
340/350-050	3000-12	-	3.39 (86)	3.82 (97)
340/350-075	3000-12	2.09 (53)	4.37 (111)	4.80 (122)
340/350-100	3000-12	3.07 (78)	5.35 (136)	5.79 (147)
340/350-115	3000-12	3.66 (93)	5.94 (151)	6.38 (162)
340/350-125	3000-12	4.06 (103)	6.34 (161)	6.77 (172)
340/350-150	3000-12	5.04 (128)	7.32 (186)	7.76 (197)
340/350-175	3000-12	6.02 (153)	8.35 (212)	8.82 (224)
340/350-200	3000-12	7.01 (178)	9.29 (236)	9.72 (247)
340/350-225	3000-12	7.99 (203)	10.28 (261)	10.71 (272)
340/350-250	3000-12	8.98 (228)	11.26 (286)	11.69 (297)

3000-12 = Full set, 4 parts, 2 with pin, 2 with bore
 3000-1 = Mounting bracket with bore, 1 part left/right
 3000-2 = Mounting bracket with pin, 1 part left/right

Strain Relief for Polymer Mounting Brackets (pivoting or locking)

The strain relief tiewrap plates can be snapped directly onto the mounting bracket without additional hardware. When the mounting brackets are bolted into place, the tiewrap plates are also connected firmly to the machine surface. No separate installation is necessary. Cable tiewraps secure cables using the "teeth" of the tiewrap plate for time-saving, effective strain relief.



Tiewrap plate as an individual part

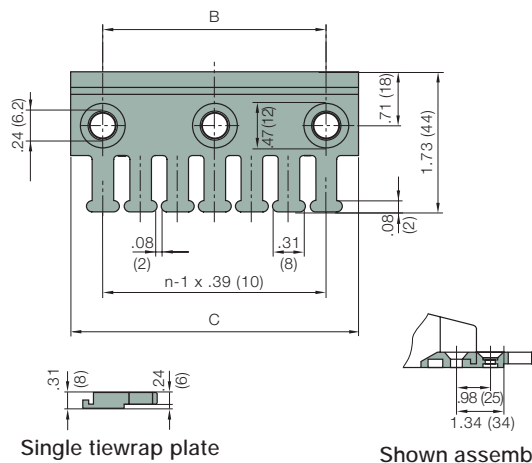

Tiewrap Plates	n Number of Teeth	C Overall Width	B Distance Between Bore Holes	Center Bore Holes
3050-ZB	5	1.97 (50)	1.18 (30)	no
3075-ZB	7	2.95 (75)	2.17 (55)	no
3100-ZB	10	3.94 (100)	3.15 (80)	no
3115-ZB	11	4.53 (115)	3.74 (95)	no
3125-ZB	12	4.92 (125)	4.13 (105)	no
3150-ZB	15	5.91 (150)	5.12 (130)	no
3175-ZB	17	6.89 (175)	6.10 (155)	no
3200-ZB	20	7.87 (200)	7.09 (180)	yes
3225-ZB	22	8.86 (225)	8.07 (205)	yes
3250-ZB	25	9.84 (250)	9.06 (230)	yes

Cable tiewraps as individual parts

Cable tiewraps	Width x Length	Maximum Ø	Tensile Strength
100 pieces/bag	in. (mm)	in. (mm)	lbs (N)
CFB-001	.19 x 5.91 (4.8 x 150)	1.42 (36)	50 (222)

- Other strain relief elements
- ▶ Strain Relief, Chapter 10

Series 340/350 E2 "medium"

"Double" strain relief

If an Energy Chain® is harnessed with a very large number of cables, strain relief may be necessary at two levels. Our 30XX-Z and 30XX-ZS strain relief systems were developed for this purpose. They can be placed in any position along the Energy Chain®. As required, the 30XX-ZS strain relief system is simply clamped onto the crossbar of the chain link. The 30XX-Z strain relief system is simply clamped onto the opening crossbar or onto the fixed crossbar of the chain link, as needed. If the strain relief system is to be fastened to the crossbars of the KMA, the 30XX-ZS strain relief system is used for both crossbars.



Part No. for Fixed Port	Part No. for Crossbars or KMA	Width, Strain Relief in. (mm)
3050-Z	3050-ZS	1.97 (50)
3075-Z	3075-ZS	2.95 (75)



Strain relief for KMA

When a profile rail is used, the strain relief element can be attached directly to the KMA brackets without using any bolts. This is accomplished by simply clamping the tiwrap plate onto the profile rail. The profile rail can be placed at the top, bottom or both top and bottom of the KMA bracket to accommodate both tiwrap plates and strain relief clamps simultaneously.



Clip-on tiwrap plates for the profile rail

For easy assembly without bolts, the 3050-ZC and 3075-ZC plates can be clipped directly into the profile rail without a bolt assembly.



Part No.	Width, Strain Relief in. (mm)
3050-ZC	1.97 (50)
3075-ZC	2.95 (75)

Strain relief for KMA and steel mounting brackets

Clip-on connection is not possible with steel mounting brackets. In this case, the tiwrap plates must be bolted directly into the separate bore holes in front of the mounting bracket. Or, the 30XX-Z and 30XX-ZS double strain relief system can be substituted if preferred.

► Chapter 10



PDF: www.igus.com/echainpdf.asp
 Specs/CAD/RFO: www.igus.com/echain.asp
 RoHS info: www.igus.com/RoHS.asp



Order example

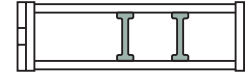
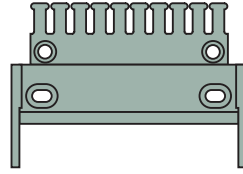
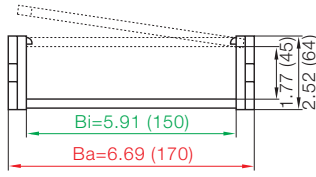

1. Chain selection:

350-150-100-0



2. Mounting Brackets:

3150-34-PZB

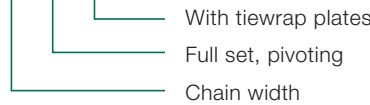

3. Interior separation:

2 separators unassembled (Part No. 301), or assembled every other link (Part No. 311). Alternative interior separation configuration according to design layout possible.

For 6.56 ft (2 m) chain, color black, with pivoting mounting brackets
6.56 ft (2 m) 350-150-100-0 and 3150-34PZ

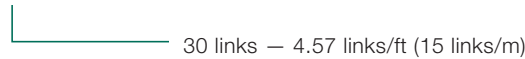

4. Additional information on guide troughs ► Chapter 9



Technical data

Chain Type	Weight Per Link		Weight	
	(oz.)	(g)	(lbs/ft)	(kg/m)
340/350-050	0.24	(0.107)	1.08	(1.603)
340/350-075	0.26	(0.119)	1.19	(1.778)
340/350-100	0.28	(0.128)	1.29	(1.925)
340/350-115	0.29	(0.132)	1.33	(1.985)
340/350-125	0.30	(0.135)	1.36	(2.025)
340/350-150	0.32	(0.144)	1.45	(2.165)
340/350-175	0.34	(0.152)	1.53	(2.278)
340/350-200	0.36	(0.163)	1.65	(2.448)
340/350-225	0.38	(0.172)	1.74	(2.587)
340/350-250	0.40	(0.182)	1.83	(2.725)

Material	igumid G
Permitted temperature	-40°/+266°F (-40°/+130°C)
Gliding speed max.	16.4 ft/s (5 m/s)
Unsupported V max.	32.8 ft/s (10 m/s)
Flammability class	VDE 0304 IIC UL94 HB

● Details of material properties

► Design, Chapter 1

Assembly Instructions



1. To open crossbars: press screwdriver into tab on top of link, lever screwdriver until crossbar opens



2. Repeat Step 1 on other side



3. To close crossbars: push down on crossbar with thumb until it snaps into place



4. Joining chain sections: push sections together; angle one side until pin snaps into bore; repeat on other side



5. Separating chain sections: insert screwdriver between two links



6. Twist until pin disengages from bore; pull sections apart



7. Attaching mounting brackets: snap bracket into link (see Step 4 - "Joining chain sections")



8. Snap tie-wrap plate into bottom groove of the mounting bracket

Guide Troughs

Guide troughs are used with applications where the upper run of the Energy Chain® glides on the lower run. If using igus® steel guide troughs, the following components are required:

- Full travel length of guide trough
Part Number 93-30
- 1/2 travel length of glide bars
Part number 93-01
- Installation sets as end connectors
Part Number 93-50 -XX

-XX indicates the length of the profile rail on which the guide trough is mounted. The values and part numbers are specified in the table on the left. The standard length of the trough components and glide bars is 6.56 ft (2 m.) The required overall length of the guide trough directly correlates to the length of travel.

Example:

Length of travel 164 ft (50 m)
Center mounted

Required guide troughs:

164 ft (50 m) guide trough
82 ft (25 m) glide bar
= 25 sections of 6.56 ft (2 m) guide trough
Part No. 93-30

= 13 sections of 6.56 ft (2 m) glide bar
Part No. 93-01

Required number of installation sets:
= Number of guide trough components + 1
= 25 + 1 = 26

Part number of the installation sets

Example: 93-50-300 for 15.75" (400 mm) long profile rail.



Width of Crossbar
350-075-200-0

	B_{Ri}	Installation Part No.
-050	2.95 (75)	93-50-150
-075	3.94 (100)	93-50-200
-100	4.92 (125)	93-50-250
-115	5.51 (140)	93-50-250
-125	5.91 (150)	93-50-300
-150	6.89 (175)	93-50-300
-175	7.87 (200)	93-50-300
-200	8.86 (225)	93-50-350
-225	9.84 (250)	93-50-350
-250	10.83 (275)	93-50-400

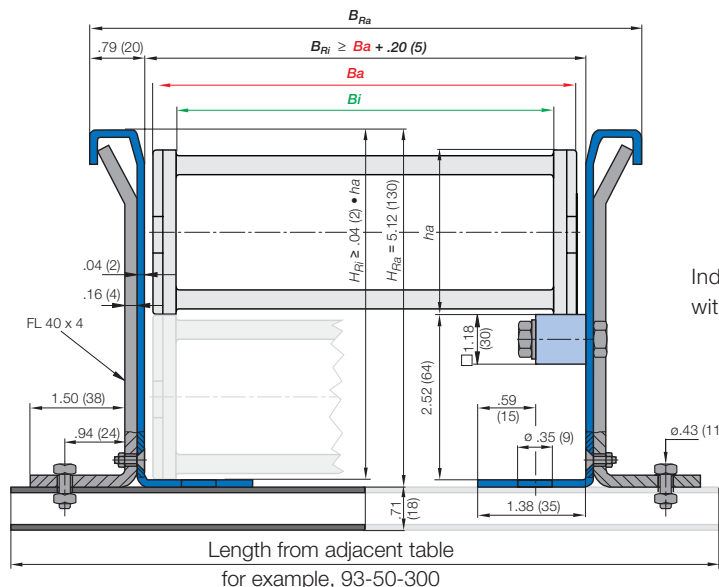

- Guide trough
- Glide bars
- Installation set "Basic"
- C-profile rail

Individual attachment without profile rail

Length from adjacent table for example, 93-50-300

Standard length profile rail

* Specialized guide trough available upon request

PDF: www.igus.com/echainpdf.asp
Specs/CAD/RFO: www.igus.com/echain.asp
RoHS info: www.igus.com/RoHS.asp



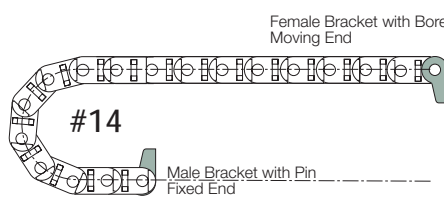
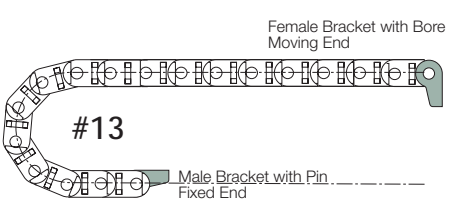
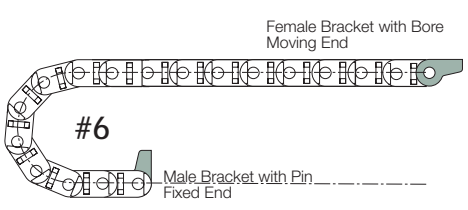
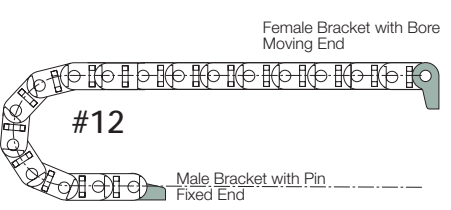
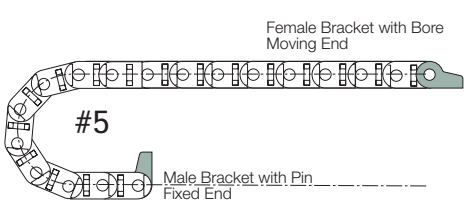
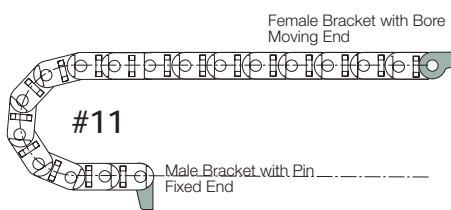
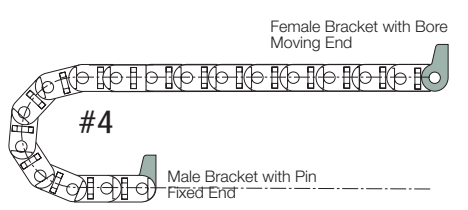
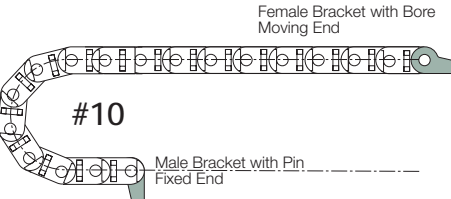
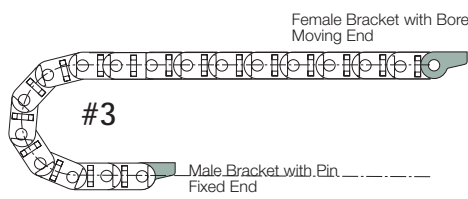
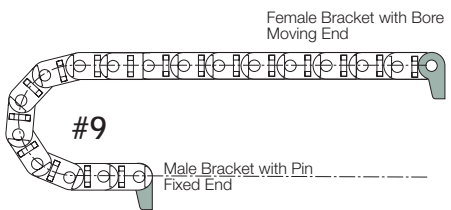
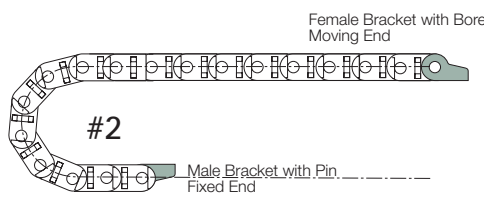
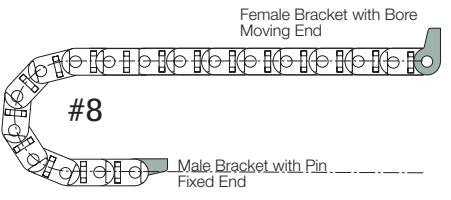
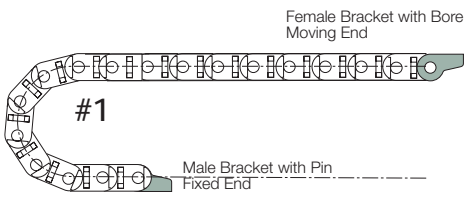
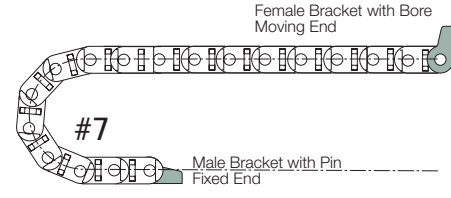
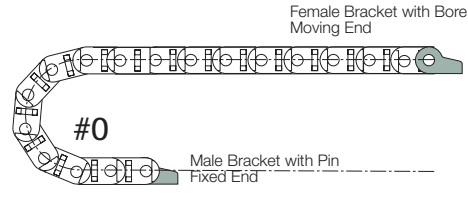

● Not all configurations apply to all mounting brackets.

Please refer to bracket specifications pages of each individual series.

