

Automation systems
Drive solutions



Controls
Inverters

Motors

Gearboxes
Engineering Tools

Contents of the L-force catalogue

About Lenze		Lenze makes many things easy for you. A matter of principle: the right products for every application. L-force product portfolio	
Automation systems		Controller-based Automation	1.1
		Drive-based automation	1.2
Drive solutions		HighLine tasks	2.1
		StateLine tasks	2.2
		Baseline tasks	2.3
Controls	Cabinet Controller	Controller 3200 C	3.1
		I/O system 1000	3.2
	Panel Controller	Controller p500	3.3
		Monitor Panel	3.4
Inverters	Decentralised	Inverter Drives 8400 protec	4.1
		Inverter Drives 8400 motec	4.2
		Inverter Drives SMV IP65	4.3
	Cabinet	Servo Drives 9400 HighLine	4.4
		Inverter Drives 8400 TopLine	4.5
		Servo Inverters i700	4.6
		Inverter Drives 8400 HighLine	4.7
		Inverter Drives 8400 StateLine	4.8
		Inverter Drives SMV IP31	4.9
		Inverter Drives 8400 Baseline	4.10
Motors	Servo motors	MCS synchronous servo motors	5.1
		MD□KS synchronous servo motors	5.2
		MQA asynchronous servo motors	5.3
		MCA asynchronous servo motors	5.4
	Three-phase AC motors	MF three-phase AC motors	5.5
		MH three-phase AC motors	5.6
		MD three-phase AC motors	5.7
		m300 Lenze Smart Motor	5.8
		MD/MH basic three-phase AC motors	5.9
Gearboxes	Axial gearbox	g700-P planetary gearbox	6.1
		MPR/MPG planetary gearboxes	6.2
		g500-H helical gearbox	6.3
		GST helical gearboxes	6.4
		g500-S shaft-mounted helical gearbox	6.5
		GFL shaft-mounted helical gearboxes	6.6
	Right-angle gearbox	g500-B bevel gearbox	6.7
		GKR bevel gearboxes	6.8
		GKS helical-bevel gearboxes	6.9
		GSS helical-worm gearboxes	6.10
Motor data	Assignment see above	6.11	
Engineering Tools		Navigator	7.1
		Drive Solution Designer	7.2
		Drive Solution Catalogue	7.3
		Engineer	7.4
		PLC Designer	7.5
		VisiWinNET®	7.6
		EASY Starter	7.7

 Selected portfolio
 Additional portfolio

Lenze makes many things easy for you.

With our motivated and committed approach, we work together with you to create the best possible solution and set your ideas in motion - whether you are looking to optimise an existing machine or develop a new one. We always strive to make things easy and seek perfection therein. This is anchored in our thinking, in our services and in every detail of our products. It's as easy as that!

1

Developing ideas

Are you looking to build the best machine possible and already have some initial ideas? Then get these down on paper together with us, starting with small innovative details and stretching all the way to completely new machines. Working together, we will develop an intelligent and sustainable concept that is perfectly aligned with your specific requirements.

2

Drafting concepts

We see welcome challenges in your machine tasks, supporting you with our comprehensive expertise and providing valuable impetus for your innovations. We take a holistic view of the individual motion and control functions here and draw up consistent, end-to-end drive and automation solutions for you - keeping everything as easy as possible and as extensive as necessary.

3

Implementing solutions

Our easy formula for satisfied customers is to establish an active partnership with fast decision-making processes and an individually tailored offer. We have been using this simple principle to meet the ever more specialised customer requirements in the field of mechanical engineering for many years.

4

Manufacturing machines

Functional diversity in perfect harmony: as one of the few full-range providers in the market, we can provide you with precisely those products that you actually need for any machine task – no more and no less. Our L-force product portfolio, a consistent platform for implementing drive and automation tasks, is invaluable in this regard.

5

Ensuring productivity

Productivity, reliability and new performance peaks on a daily basis – these are our key success factors for your machine. After delivery, we offer you cleverly devised service concepts to ensure continued safe operation. The primary focus here is on technical support, based on the excellent application expertise of our highly-skilled and knowledgeable after-sales team.

A matter of principle: the right products for every application.

Lenze's extensive L-force product portfolio follows a very simple principle. The functions of our finely scaled products are assigned to the three lines Base-Line, State-Line or High-Line.

But what does this mean for you? It allows you to quickly recognise which products represent the best solution for your own specific requirements.

Powerful products with a major impact:

- Easy handling
- High quality and durability
- Reliable technologies in tune with the latest developments

Lenze products undergo the most stringent testing in our own laboratory. This allows us to ensure that you will receive consistently high quality and a long service life. In addition to this, five logistics centres ensure that the Lenze products you select are available for quick delivery anywhere across the globe. It's as easy as that!

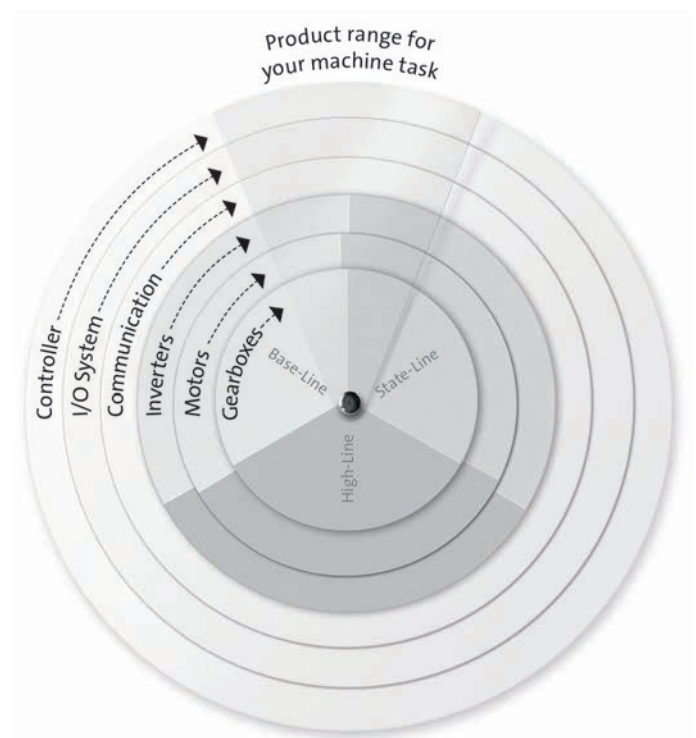

L-force product portfolio

Controls

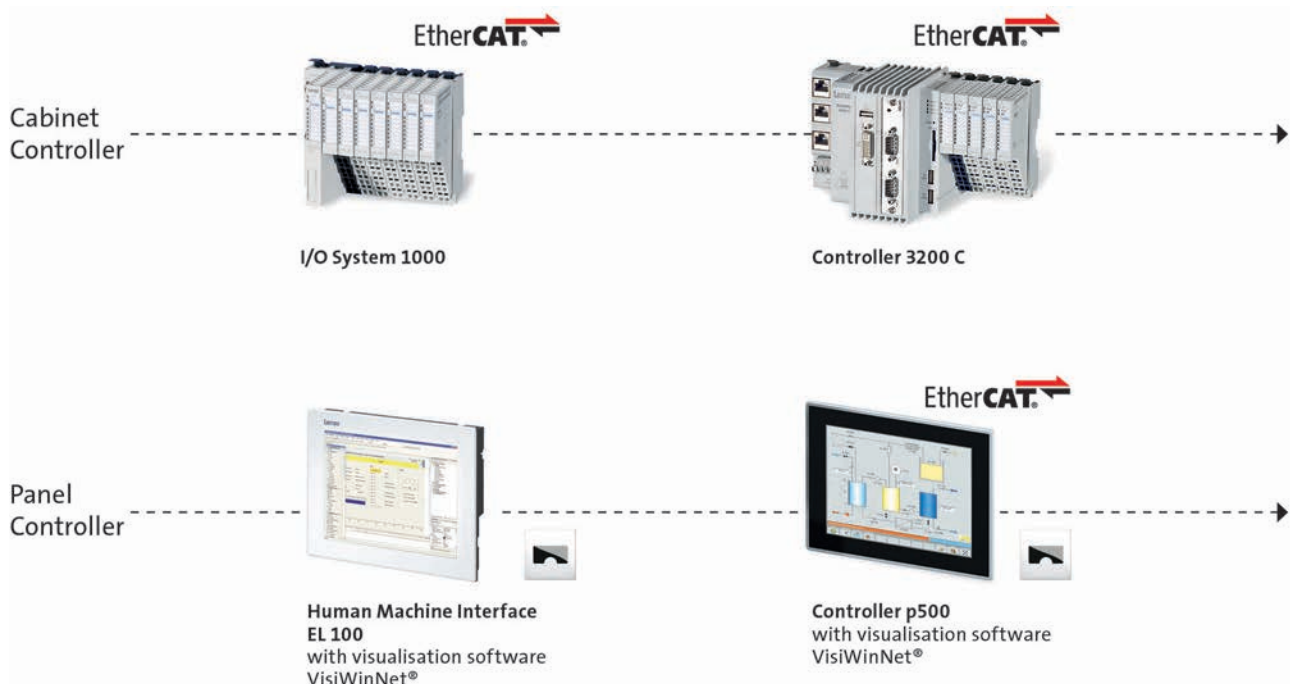

Engineering Tools

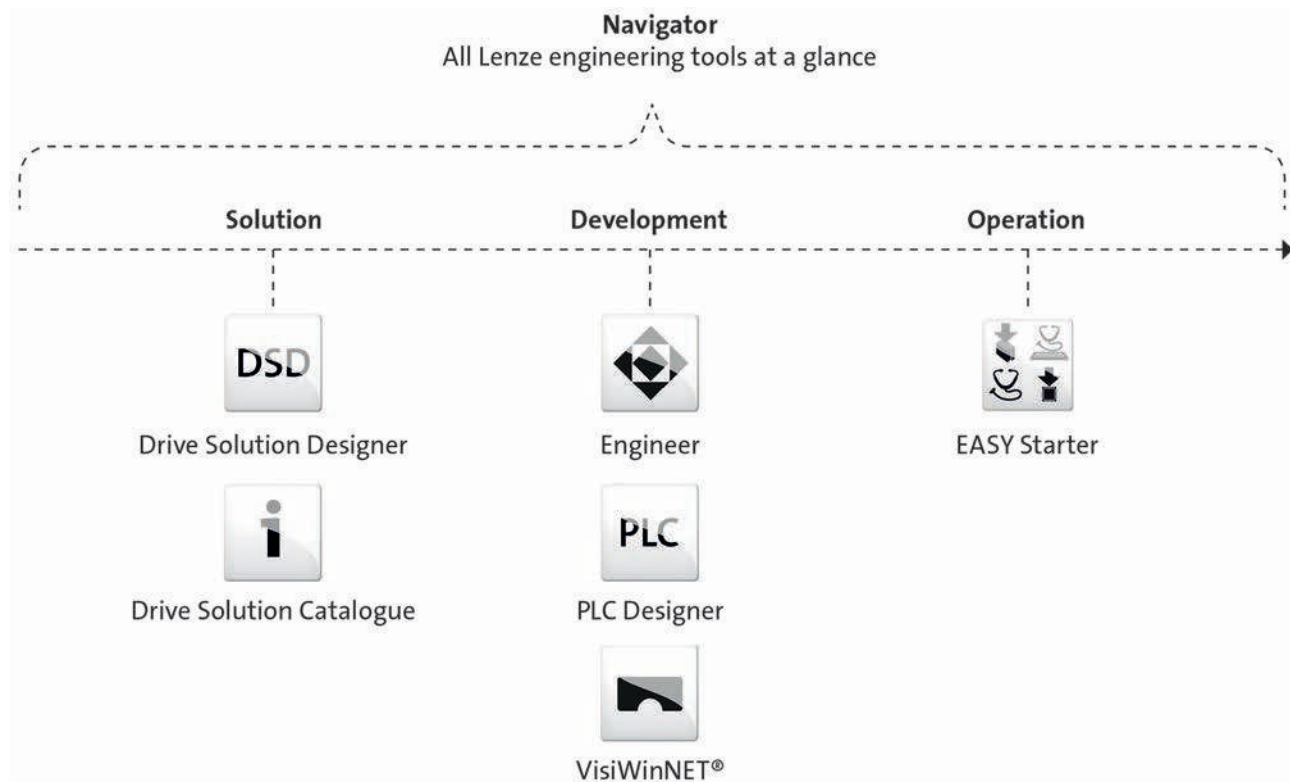

L-force product portfolio

Inverters

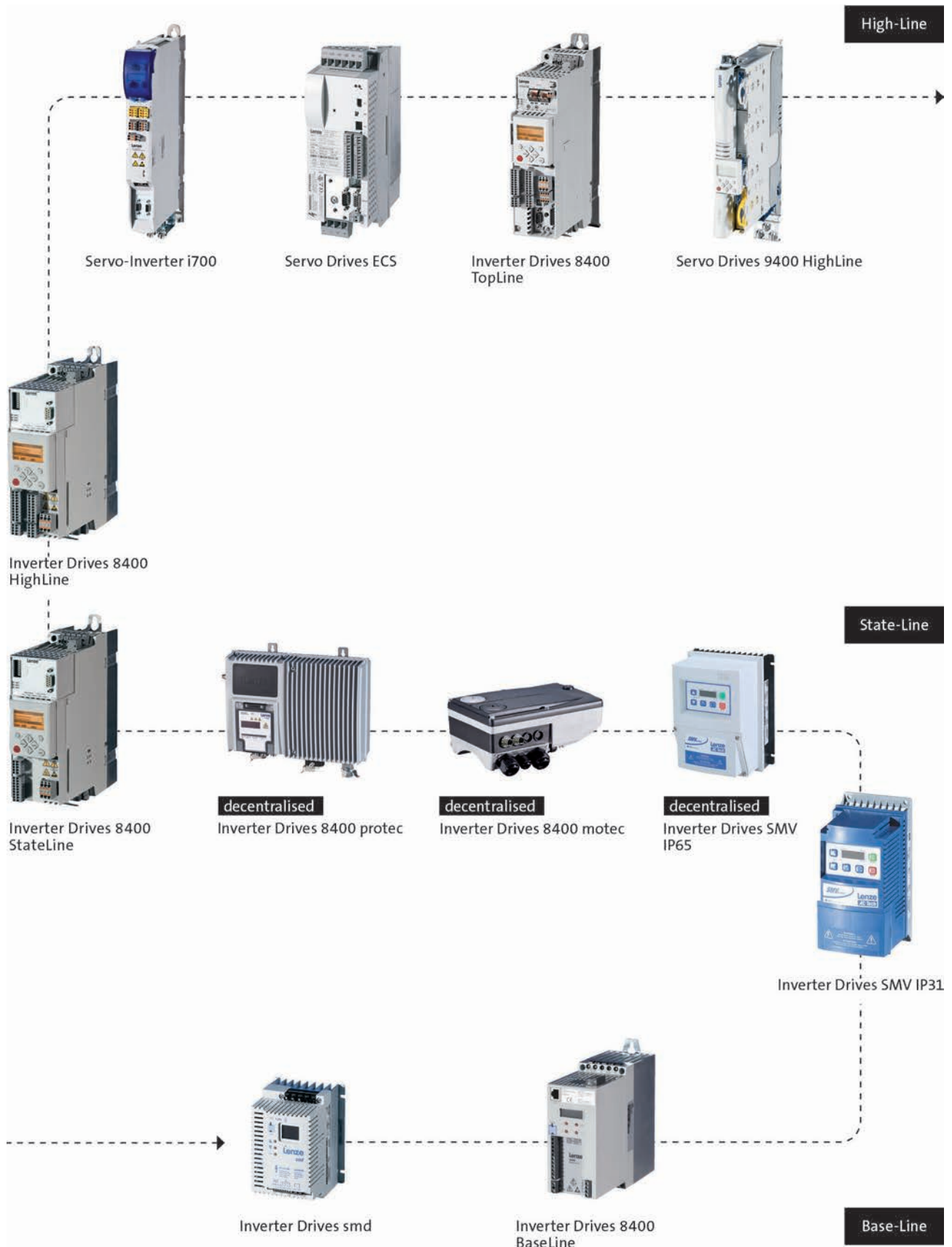

L-force product portfolio

Motors



L-force product portfolio

Gearboxes

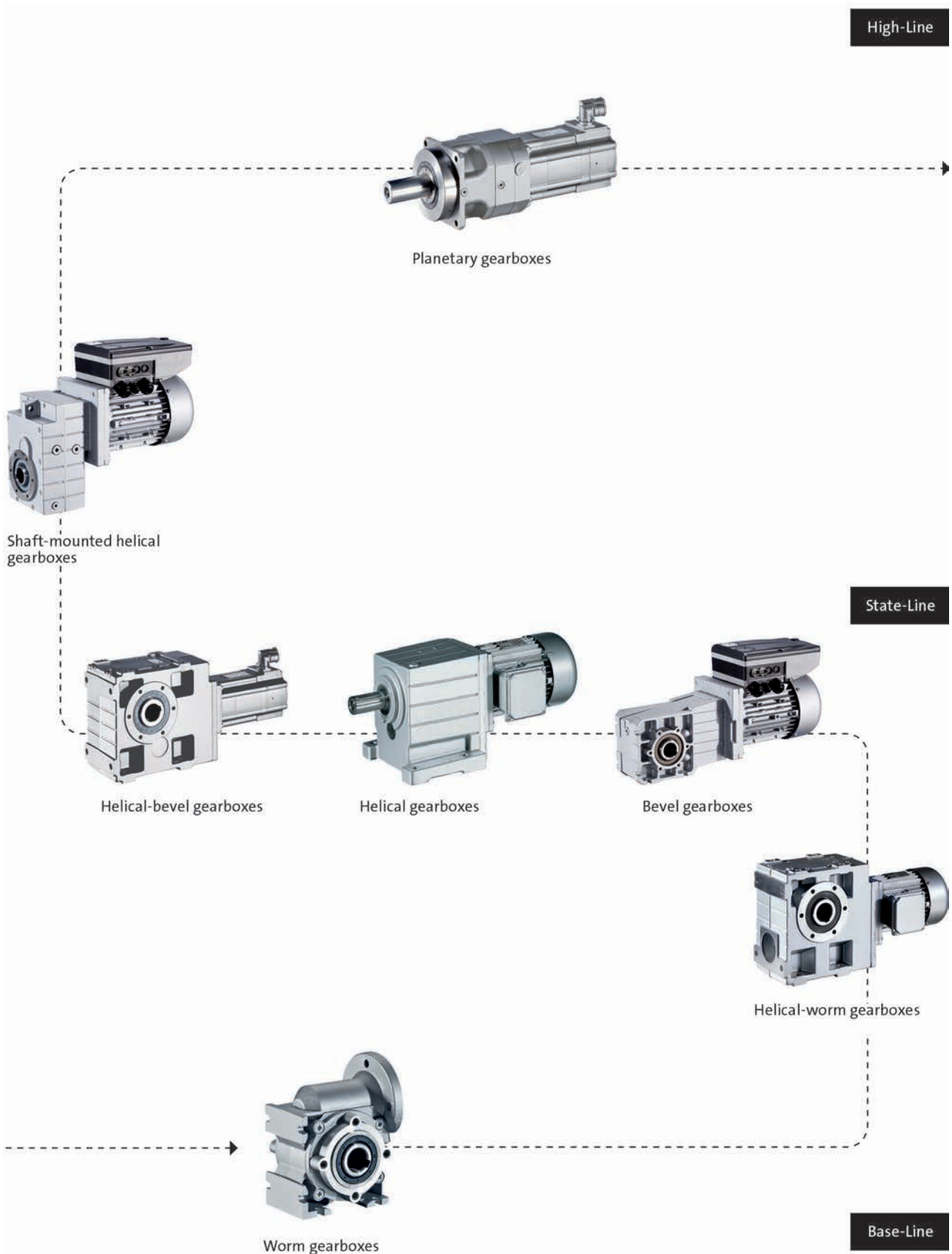

Basic MD/MH three-phase AC motors

0.06 ... 45 kW

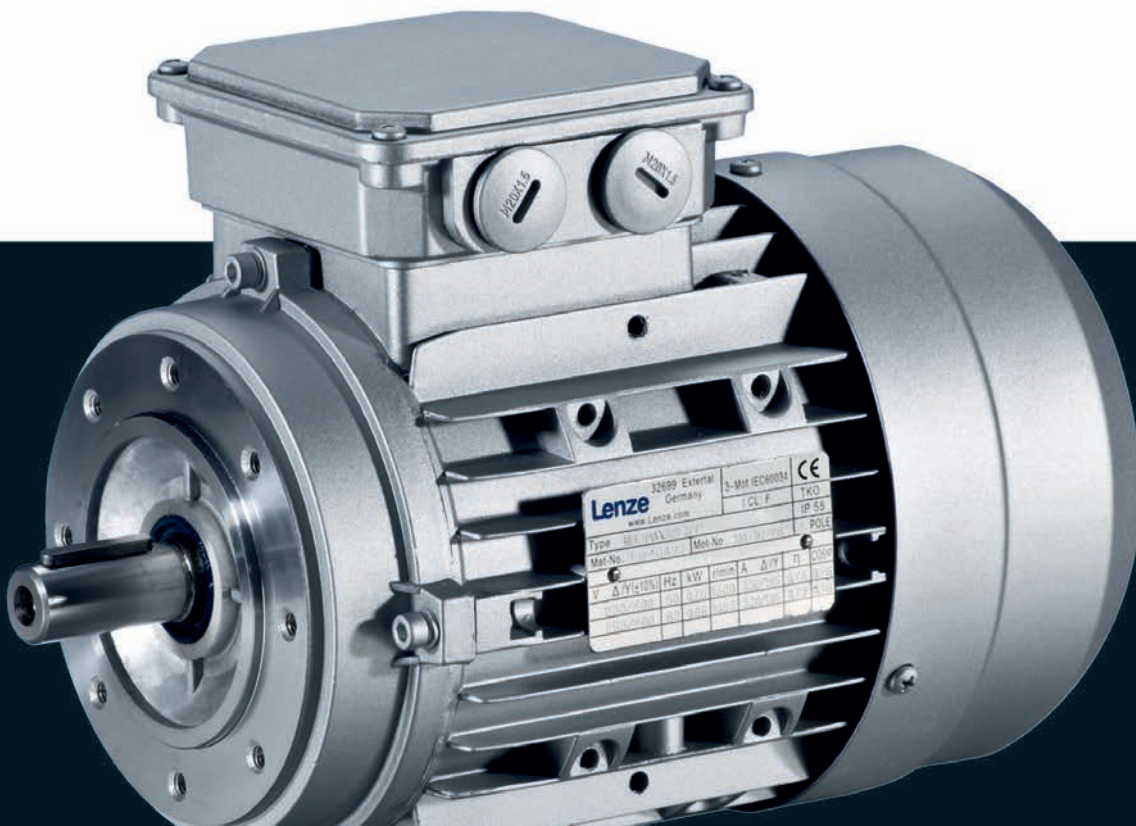

Basic MD/MH three-phase AC motors



Contents

General information	List of abbreviations	5.9 - 4
	Product key	5.9 - 5
	Product information	5.9 - 6
Technical data	Rated data for 50 Hz	5.9 - 7
	Rated data for 60 Hz	5.9 - 11
	Dimensions, self-ventilated (2-pole)	5.9 - 16
	Dimensions, self-ventilated (4-pole)	5.9 - 22
	Dimensions, self-ventilated (6-pole)	5.9 - 32

Basic MD/MH three-phase AC motors

General information



List of abbreviations

$\eta_{100\%}$	[%]	Efficiency
$\eta_{50\%}$	[%]	Efficiency
$\eta_{75\%}$	[%]	Efficiency
$\cos \phi$		Power factor
$I_{N,\Delta}$	[A]	Rated current
$I_{N,Y}$	[A]	Rated current
I_a/I_N		Starting current
m	[kg]	Mass
M_a	[Nm]	Starting torque
M_b	[Nm]	Stalling torque
M_N	[Nm]	Rated torque
n_N	[r/min]	Rated speed
P_N	[kW]	Rated power
$U_{N,\Delta}$	[V]	Rated voltage
$U_{N,Y}$	[V]	Rated voltage

EN 50347	Three-phase asynchronous motors for general use with standardised dimensions and outputs
----------	--

Basic MD/MH three-phase AC motors

General information



Product key

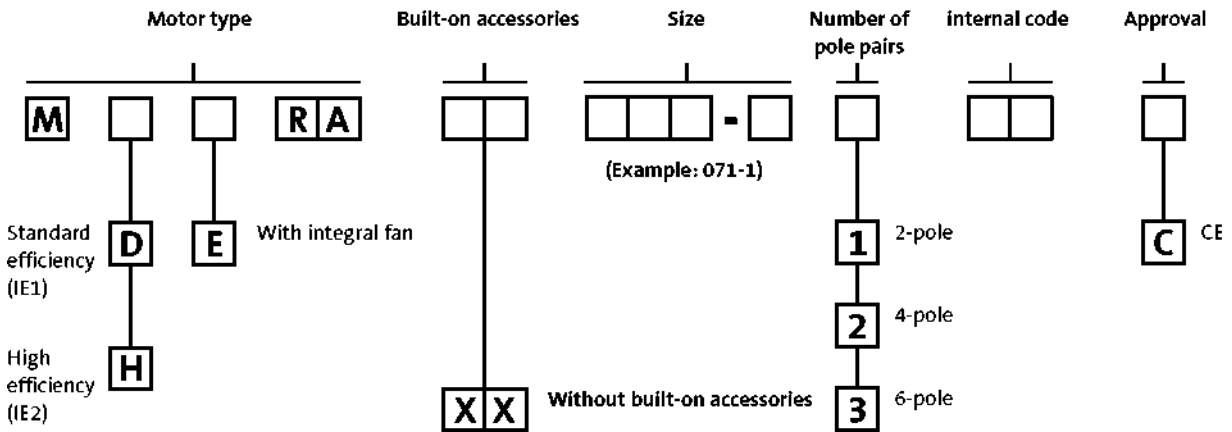

Basic MD/MH three-phase AC motors



General information

Product information

Many straightforward industrial applications are the perfect example of when three-phase AC motors are required for mains operation without any of the typical options (e.g. blower, brake). That is where the robust three-phase AC motors from the Basic series come into play. These round off the section of the Lenze product portfolio that concentrates on cost-optimised motors.

- The 2, 4 and 6-pole motors in sizes 56 to 132 are available in B3, B5 and B14 designs. In addition, 4-pole motors are available in designs B3 and B5 up to a size of 225.
- All motors with a power of 0.75 kW or above meet the requirements of efficiency class IE2 (high efficiency) according to IEC60034-30. The efficiency was measured in accordance with IEC 60034-2-1.
- The motors in sizes 056 to 132 have an aluminium housing. From size 160 upwards, they feature a housing made from cast iron.
- Designs B3 and B5 come with a basalt grey coating (RAL7012) as standard. In the case of design B14, no coating is applied up to size 132.
- The motors feature an integrated integral fan as standard.
- The integrated thermal sensors enable continuous temperature monitoring and are coordinated with the temperature class F (155°C) of the motors.
The following thermal sensors are used:
 - Motor frame size 56 to 132, design B3: 1x PTC
 - Motor frame size 56 to 132, designs B5 and B14: 1x thermal contact
 - Motor frame size 160 to 225, designs B3 and B5: 3x PTC
- The motors feature high-quality ball bearings.
- IP55 degree of protection ensures that the series is able to cope with the environmental conditions.
- The mounting dimensions conform to standards IEC 60072-1 and DIN EN 50347.
- All motor data assumes a maximum ambient temperature (cooling air temperature) of 40°C and a maximum site altitude of 1000 m above sea level.



Basic MD/MH three-phase AC motors



Technical data

Rated data for 50 Hz

2-pole motors

	P_N	n_N	$U_{N,\Delta}$	$I_{N,\Delta}$	$U_{N,Y}$	$I_{N,Y}$	I_a/I_N
			$\pm 10\%$		$\pm 10\%$		
	[kW]	[r/min]	[V]	[A]	[V]	[A]	
MDERAXX056-11V1C	0.090	2710	230	0.64	400	0.37	4.00
MDERAXX056-21V1C	0.12	2710	230	0.78	400	0.45	4.00
MDERAXX063-11V1C	0.18	2720	230	0.95	400	0.55	5.50
MDERAXX063-21V1C	0.25	2720	230	1.25	400	0.72	5.50
MDERAXX071-11V1C	0.37	2760	230	1.63	400	0.94	6.10
MDERAXX071-21V1C	0.55	2820	230	2.30	400	1.33	6.10
MHERAXX080-11V1C	0.75	2880	230	3.04	400	1.75	7.00
MHERAXX080-31V1C	1.10	2880	230	4.30	400	2.47	7.00
MHERAXX090-11V1C	1.50	2900	230	5.16	400	2.96	8.50
MHERAXX090-31V1C	2.20	2900	230	7.37	400	4.24	8.50
MHERAXX100-31V1C	3.00	2900	230	9.80	400	5.63	9.00
MHERAXX112-21V1C	4.00	2920	400	7.52			9.00
MHERAXX132-11V1C	5.50	2930	400	10.2			8.50
MHERAXX132-21V1C	7.50	2930	400	13.8			8.50

	M_N	M_a	M_b	$\cos \phi$	$\eta_{50\%}$	$\eta_{75\%}$	$\eta_{100\%}$	m
	[Nm]	[Nm]	[Nm]		[%]	[%]	[%]	[kg]
MDERAXX056-11V1C	0.32	0.58	0.64	0.70			50.0	3.20
MDERAXX056-21V1C	0.42	0.76	0.84	0.70			55.0	3.40
MDERAXX063-11V1C	0.63	1.39	1.39	0.73			65.0	3.90
MDERAXX063-21V1C	0.88	1.94	1.94	0.76			66.0	4.40
MDERAXX071-11V1C	1.28	2.82	2.82	0.81			70.0	6.20
MDERAXX071-21V1C	1.86	4.09	4.28	0.82			73.0	6.30
MHERAXX080-11V1C	2.49	6.23	6.47	0.78	76.3	79.0	79.3	11.0
MHERAXX080-31V1C	3.65	9.13	9.49	0.79	78.3	81.0	81.3	13.0
MHERAXX090-11V1C	4.94	10.9	12.4	0.88	81.5	83.2	83.0	16.0
MHERAXX090-31V1C	7.24	15.9	18.1	0.89	83.4	84.7	84.2	19.0
MHERAXX100-31V1C	9.88	21.7	24.7	0.90	85.0	86.0	85.4	24.0
MHERAXX112-21V1C	13.1	28.8	32.8	0.89	86.0	87.0	86.3	28.0
MHERAXX132-11V1C	17.9	39.4	44.8	0.89	86.0	87.5	87.5	40.0
MHERAXX132-21V1C	24.4	53.7	61.0	0.89	87.6	88.8	88.4	43.0

Basic MD/MH three-phase AC motors



Technical data

Rated data for 50 Hz

4-pole motors

	P_N	n_N	$U_{N,\Delta}$	$I_{N,\Delta}$	$U_{N,Y}$	$I_{N,Y}$	I_a/I_N
			$\pm 10\%$		$\pm 10\%$		
	[kW]	[r/min]	[V]	[A]	[V]	[A]	
MDERAXX056-12V1C	0.060	1330	230	0.47	400	0.27	4.00
MDERAXX056-22V1C	0.090	1330	230	0.62	400	0.36	4.00
MDERAXX063-12V1C	0.12	1340	230	0.73	400	0.42	4.40
MDERAXX063-32V1C	0.18	1340	230	1.06	400	0.61	4.40
MDERAXX071-12V1C	0.25	1345	230	1.30	400	0.75	5.20
MDERAXX071-32V1C	0.37	1340	230	1.84	400	1.06	5.20
MDERAXX071-42V1C	0.55	1390	230	2.58	400	1.49	5.30
MDERAXX080-12V1C	0.55	1425	230	2.46	400	1.41	8.80
MHERAXX080-32V1C	0.75	1425	230	3.24	400	1.86	8.80
MHERAXX090-12V1C	1.10	1450	230	4.29	400	2.47	8.80
MHERAXX090-32V1C	1.50	1450	230	5.76	400	3.31	8.50
MHERAXX100-12V1C	2.20	1440	230	8.40	400	4.83	9.00
MHERAXX100-32V1C	3.00	1440	230	11.3	400	6.49	9.00

	M_N	M_a	M_b	$\cos \phi$	$\eta_{50\%}$	$\eta_{75\%}$	$\eta_{100\%}$	m
	[Nm]	[Nm]	[Nm]		[%]	[%]	[%]	[kg]
MDERAXX056-12V1C	0.43	0.60	0.86	0.65			50.0	3.20
MDERAXX056-22V1C	0.65	1.17	1.30	0.73			50.0	3.40
MDERAXX063-12V1C	0.86	1.55	1.72	0.72			57.0	4.00
MDERAXX063-32V1C	1.28	2.30	2.56	0.73			58.0	4.50
MDERAXX071-12V1C	1.77	3.72	3.89	0.74			65.0	6.10
MDERAXX071-32V1C	2.64	5.54	5.81	0.75			67.0	6.70
MDERAXX071-42V1C	3.78	8.32	9.45	0.75			71.0	9.20
MDERAXX080-12V1C	3.69	8.49	9.23	0.73			77.0	12.0
MHERAXX080-32V1C	5.03	11.6	12.6	0.73	75.6	78.8	79.6	14.0
MHERAXX090-12V1C	7.24	16.7	18.1	0.79	78.6	81.0	81.4	17.0
MHERAXX090-32V1C	9.88	22.7	24.7	0.79	80.0	82.4	82.8	20.0
MHERAXX100-12V1C	14.6	33.6	36.5	0.78	82.0	84.0	84.3	25.0
MHERAXX100-32V1C	19.9	45.8	49.8	0.78	84.0	85.6	85.5	29.0

Basic MD/MH three-phase AC motors



Technical data

Rated data for 50 Hz

4-pole motors

	P_N	n_N	$U_{N,\Delta}$ $\pm 10\%$	$I_{N,\Delta}$	$U_{N,Y}$ $\pm 10\%$	$I_{N,Y}$	I_a/I_N
	[kW]	[r/min]	[V]	[A]	[V]	[A]	
MHERAXX112-22V1C	4.00	1460	400	8.00			8.80
MHERAXX132-12V1C	5.50	1460	400	11.0			8.50
MHERAXX132-22V1C	7.50	1460	400	14.7			8.20
MHERAXX160-22V1C	11.0	1460	400	20.5			7.00
MHERAXX160-32V1C	15.0	1460	400	27.8			7.50
MHERAXX180-22V1C	18.5	1470	400	33.7			7.50
MHERAXX180-32V1C	22.0	1470	400	39.9			7.50
MHERAXX200-32V1C	30.0	1470	400	52.2			7.20
MHERAXX225-12V1C	37.0	1480	400	65.6			7.20
MHERAXX225-22V1C	45.0	1480	400	79.3			7.20

	M_N	M_a	M_b	$\cos \phi$	$\eta_{50\%}$	$\eta_{75\%}$	$\eta_{100\%}$	m
	[Nm]	[Nm]	[Nm]		[%]	[%]	[%]	[kg]
MHERAXX112-22V1C	26.2	52.4	57.6	0.83	86.5	87.4	87.0	33.0
MHERAXX132-12V1C	36.0	72.0	79.2	0.82	86.8	87.9	87.8	47.0
MHERAXX132-22V1C	49.1	98.2	108	0.83	88.0	89.2	89.0	60.0
MHERAXX160-22V1C	71.9	158	180	0.85	90.2	90.7	90.3	115
MHERAXX160-32V1C	98.1	216	245	0.86	90.8	91.4	91.0	135
MHERAXX180-22V1C	120	264	300	0.86	90.6	91.3	91.3	170
MHERAXX180-32V1C	143	315	358	0.86	90.9	91.8	91.8	184
MHERAXX200-32V1C	195	429	488	0.89	91.8	92.5	92.5	235
MHERAXX225-12V1C	239	526	598	0.87	93.2	94.0	93.9	290
MHERAXX225-22V1C	290	638	725	0.87	92.6	93.3	93.3	326

Basic MD/MH three-phase AC motors



Technical data

Rated data for 50 Hz

6-pole motors

	P_N	n_N	$U_{N,\Delta}$	$I_{N,\Delta}$	$U_{N,Y}$	$I_{N,Y}$	I_a/I_N
			$\pm 10\%$		$\pm 10\%$		
	[kW]	[r/min]	[V]	[A]	[V]	[A]	
MDERAXX063-13V1C	0.090	860	230	0.80	400	0.46	4.00
MDERAXX063-23V1C	0.12	860	230	0.99	400	0.57	4.00
MDERAXX071-13V1C	0.18	860	230	1.21	400	0.70	4.00
MDERAXX071-23V1C	0.25	860	230	1.56	400	0.90	4.00
MDERAXX080-23V1C	0.37	885	230	2.23	400	1.29	4.70
MDERAXX080-33V1C	0.55	885	230	3.08	400	1.78	4.70
MHERAXX090-13V1C	0.75	920	230	3.54	400	2.03	7.50
MHERAXX090-33V1C	1.10	920	230	5.04	400	2.90	7.50
MHERAXX100-33V1C	1.50	925	230	6.65	400	3.82	7.50
MHERAXX112-23V1C	2.20	925	230	9.38	400	5.39	7.50
MHERAXX132-13V1C	3.00	950	230	12.1	400	6.93	8.50
MHERAXX132-23V1C	4.00	950	400	8.98			9.00
MHERAXX132-33V1C	5.50	950	400	12.2			9.50

	M_N	M_a	M_b	$\cos \phi$	$\eta_{50\%}$	$\eta_{75\%}$	$\eta_{100\%}$	m
	[Nm]	[Nm]	[Nm]		[%]	[%]	[%]	[kg]
MDERAXX063-13V1C	1.00	1.90	2.00	0.59			48.0	4.50
MDERAXX063-23V1C	1.33	2.53	2.66	0.59			51.5	5.60
MDERAXX071-13V1C	2.00	3.80	4.00	0.66			56.0	6.40
MDERAXX071-23V1C	2.78	5.28	5.56	0.68			59.0	6.50
MDERAXX080-23V1C	3.99	7.98	8.38	0.67	56.4	61.2	62.0	12.0
MDERAXX080-33V1C	5.93	11.9	12.5	0.69	61.8	65.2	65.0	16.0
MHERAXX090-13V1C	7.78	17.1	17.9	0.70	73.9	76.4	76.0	15.0
MHERAXX090-33V1C	11.4	25.1	26.2	0.70	76.0	78.5	78.3	17.0
MHERAXX100-33V1C	15.5	31.0	34.1	0.71	79.9	81.0	79.8	22.0
MHERAXX112-23V1C	22.7	49.9	49.9	0.72	81.8	82.8	81.8	25.0
MHERAXX132-13V1C	30.2	69.5	69.5	0.75	81.6	83.4	83.3	34.0
MHERAXX132-23V1C	40.2	92.5	92.5	0.76	83.3	84.2	84.6	43.0
MHERAXX132-33V1C	55.3	133	133	0.76	84.7	86.1	86.0	52.0

Basic MD/MH three-phase AC motors



Technical data

Rated data for 60 Hz

2-pole motors

	P_N	n_N	$U_{N,\Delta}$	$I_{N,\Delta}$	$U_{N,Y}$	$I_{N,Y}$	I_a/I_N
			$\pm 10\%$		$\pm 10\%$		
	[kW]	[r/min]	[V]	[A]	[V]	[A]	
MDERAXX056-11V1C	0.10	3250	265	0.64	460	0.37	4.00
MDERAXX056-21V1C	0.14	3250	265	0.78	460	0.45	4.00
MDERAXX063-11V1C	0.21	3265	265	0.95	460	0.55	5.50
MDERAXX063-21V1C	0.29	3265	265	1.25	460	0.72	5.50
MDERAXX071-11V1C	0.43	3310	265	1.63	460	0.94	6.10
MDERAXX071-21V1C	0.63	3385	265	2.30	460	1.33	6.10
MHERAXX080-11V1C	0.86	3450	265	2.98	460	1.72	7.00
MHERAXX080-31V1C	1.27	3450	265	4.18	460	2.41	7.00
MHERAXX090-11V1C	1.73	3480	265	5.16	460	2.98	8.50
MHERAXX090-31V1C	2.53	3480	265	7.28	460	4.20	8.50
MHERAXX100-31V1C	3.45	3490	265	9.52	460	5.48	9.00
MHERAXX112-21V1C	4.60	3500	460	7.44			9.00
MHERAXX132-11V1C	6.33	3520	460	10.1			8.50
MHERAXX132-21V1C	8.63	3520	460	13.6			8.50

	M_N	M_a	M_b	$\cos \phi$	$\eta_{50\%}$	$\eta_{75\%}$	$\eta_{100\%}$	m
	[Nm]	[Nm]	[Nm]		[%]	[%]	[%]	[kg]
MDERAXX056-11V1C	0.31	0.58	0.64	0.70			50.0	3.20
MDERAXX056-21V1C	0.41	0.76	0.84	0.70			55.0	3.40
MDERAXX063-11V1C	0.62	1.39	1.39	0.73			65.0	3.90
MDERAXX063-21V1C	0.86	1.94	1.94	0.76			66.0	4.40
MDERAXX071-11V1C	1.25	2.82	2.82	0.81			70.0	6.20
MDERAXX071-21V1C	1.82	4.09	4.28	0.82			73.0	6.30
MHERAXX080-11V1C	2.39	6.23	6.47	0.78	76.3	79.0	80.6	11.0
MHERAXX080-31V1C	3.50	9.13	9.49	0.79	78.3	81.0	82.4	13.0
MHERAXX090-11V1C	4.73	10.9	12.4	0.88	81.5	83.2	83.9	16.0
MHERAXX090-31V1C	6.94	15.9	18.1	0.89	83.4	84.7	85.0	19.0
MHERAXX100-31V1C	9.47	21.7	24.7	0.90	85.0	86.0	86.5	24.0
MHERAXX112-21V1C	12.6	28.8	32.8	0.89	86.0	87.0	87.2	28.0
MHERAXX132-11V1C	17.1	39.4	44.8	0.89	86.0	87.5	88.1	40.0
MHERAXX132-21V1C	23.4	53.7	61.0	0.89	87.6	88.8	89.0	43.0

► The nameplate only gives rated data for operation at 50 Hz.

Basic MD/MH three-phase AC motors



Technical data

Rated data for 60 Hz

4-pole motors

	P_N	n_N	$U_{N,\Delta}$	$I_{N,\Delta}$	$U_{N,Y}$	$I_{N,Y}$	I_a/I_N
			$\pm 10\%$		$\pm 10\%$		
	[kW]	[r/min]	[V]	[A]	[V]	[A]	
MDERAXX056-12V1C	0.070	1595	265	0.47	460	0.27	4.00
MDERAXX056-22V1C	0.10	1595	265	0.62	460	0.36	4.00
MDERAXX063-12V1C	0.14	1605	265	0.73	460	0.42	4.40
MDERAXX063-32V1C	0.21	1605	265	1.06	460	0.61	4.40
MDERAXX071-12V1C	0.29	1610	265	1.30	460	0.75	5.20
MDERAXX071-32V1C	0.43	1605	265	1.84	460	1.06	5.20
MDERAXX071-42V1C	0.63	1665	265	2.58	460	1.49	5.30
MDERAXX080-12V1C	0.63	1730	265	2.38	460	1.37	8.80
MHERAXX080-32V1C	0.86	1730	265	3.14	460	1.81	8.80
MHERAXX090-12V1C	1.27	1750	265	4.17	460	2.40	8.80
MHERAXX090-32V1C	1.73	1750	265	5.75	460	3.31	8.50
MHERAXX100-12V1C	2.53	1750	265	8.20	460	4.72	9.00
MHERAXX100-32V1C	3.45	1750	265	11.0	460	6.35	9.00

	M_N	M_a	M_b	$\cos \phi$	$\eta_{50\%}$	$\eta_{75\%}$	$\eta_{100\%}$	m
	[Nm]	[Nm]	[Nm]		[%]	[%]	[%]	[kg]
MDERAXX056-12V1C	0.41	0.60	0.86	0.65			50.0	3.20
MDERAXX056-22V1C	0.62	1.17	1.30	0.73			50.0	3.40
MDERAXX063-12V1C	0.82	1.55	1.72	0.72			57.0	4.00
MDERAXX063-32V1C	1.23	2.30	2.56	0.73			58.0	4.50
MDERAXX071-12V1C	1.70	3.72	3.89	0.74			65.0	6.10
MDERAXX071-32V1C	2.53	5.54	5.81	0.75			67.0	6.70
MDERAXX071-42V1C	3.62	8.32	9.45	0.75			71.0	9.20
MDERAXX080-12V1C	3.54	8.49	9.23	0.73			78.6	12.0
MHERAXX080-32V1C	4.82	11.6	12.6	0.73	75.6	78.8	81.0	14.0
MHERAXX090-12V1C	6.94	16.7	18.1	0.79	78.6	81.0	82.6	17.0
MHERAXX090-32V1C	9.47	22.7	24.7	0.79	80.0	82.4	84.0	20.0
MHERAXX100-12V1C	14.0	33.6	36.5	0.78	82.0	84.0	85.2	25.0
MHERAXX100-32V1C	19.1	45.8	49.8	0.78	84.0	85.6	86.2	29.0

► The nameplate only gives rated data for operation at 50 Hz.

Basic MD/MH three-phase AC motors



Technical data

Rated data for 60 Hz

4-pole motors

	P_N	n_N	$U_{N,\Delta}$ $\pm 10\%$	$I_{N,\Delta}$	$U_{N,Y}$ $\pm 10\%$	$I_{N,Y}$	I_a/I_N
	[kW]	[r/min]	[V]	[A]	[V]	[A]	
MHERAXX112-22V1C	4.60	1750	460	7.92			8.80
MHERAXX132-12V1C	6.33	1760	460	10.9			8.50
MHERAXX132-22V1C	8.63	1760	460	14.5			8.20
MHERAXX160-22V1C	12.7	1750	460	20.5			7.00
MHERAXX160-32V1C	17.3	1750	460	27.8			7.50
MHERAXX180-22V1C	21.3	1960	460	33.7			7.50
MHERAXX180-32V1C	25.3	1760	460	39.9			7.50
MHERAXX200-32V1C	34.5	1760	460	52.2			7.20
MHERAXX225-12V1C	42.5	1775	460	65.6			7.20
MHERAXX225-22V1C	51.8	1775	460	79.3			7.20

	M_N	M_a	M_b	$\cos \phi$	$\eta_{50\%}$	$\eta_{75\%}$	$\eta_{100\%}$	m
	[Nm]	[Nm]	[Nm]		[%]	[%]	[%]	[kg]
MHERAXX112-22V1C	25.1	52.4	57.6	0.83	86.5	87.4	87.8	33.0
MHERAXX132-12V1C	34.5	72.0	79.2	0.82	86.8	87.9	88.6	47.0
MHERAXX132-22V1C	47.0	98.2	108	0.83	88.0	89.2	89.4	60.0
MHERAXX160-22V1C	68.9	158	180	0.85	90.2	90.7	90.3	115
MHERAXX160-32V1C	94.0	216	245	0.86	90.8	91.4	91.0	135
MHERAXX180-22V1C	115	264	300	0.86	90.6	91.3	91.3	170
MHERAXX180-32V1C	137	315	358	0.86	90.9	91.8	91.8	184
MHERAXX200-32V1C	187	429	488	0.89	91.8	92.5	92.5	235
MHERAXX225-12V1C	229	526	598	0.87	93.2	94.0	93.9	290
MHERAXX225-22V1C	278	638	725	0.87	92.6	93.3	93.3	326

► The nameplate only gives rated data for operation at 50 Hz.

Basic MD/MH three-phase AC motors



Technical data

Rated data for 60 Hz

6-pole motors

	P_N	n_N	$U_{N,\Delta}$	$I_{N,\Delta}$	$U_{N,Y}$	$I_{N,Y}$	I_a/I_N
			$\pm 10\%$		$\pm 10\%$		
	[kW]	[r/min]	[V]	[A]	[V]	[A]	
MDERAXX063-13V1C	0.10	1030	265	0.80	460	0.46	4.00
MDERAXX063-23V1C	0.14	1030	265	0.99	460	0.57	4.00
MDERAXX071-13V1C	0.21	1030	265	1.22	460	0.70	4.00
MDERAXX071-23V1C	0.29	1030	265	1.56	460	0.90	4.00
MDERAXX080-23V1C	0.43	1060	265	2.23	460	1.29	4.70
MDERAXX080-33V1C	0.63	1060	265	3.07	460	1.78	4.70
MHERAXX090-13V1C	0.86	1150	265	3.42	460	1.97	7.50
MHERAXX090-33V1C	1.27	1150	265	4.84	460	2.79	7.50
MHERAXX100-33V1C	1.73	1140	265	6.59	460	3.80	7.50
MHERAXX112-23V1C	2.53	1155	265	9.05	460	5.21	7.50
MHERAXX132-13V1C	3.45	1170	265	11.6	460	6.70	8.50
MHERAXX132-23V1C	4.60	1170	460	8.79			9.00
MHERAXX132-33V1C	6.33	1175	460	11.8			9.50

	M_N	M_a	M_b	$\cos \phi$	$\eta_{50\%}$	$\eta_{75\%}$	$\eta_{100\%}$	m
	[Nm]	[Nm]	[Nm]		[%]	[%]	[%]	[kg]
MDERAXX063-13V1C	0.98	1.90	2.00	0.59			48.0	4.50
MDERAXX063-23V1C	1.30	2.53	2.66	0.59			51.5	5.60
MDERAXX071-13V1C	1.96	3.80	4.00	0.66			56.0	6.40
MDERAXX071-23V1C	2.72	5.28	5.56	0.68			59.0	6.50
MDERAXX080-23V1C	3.82	7.98	8.38	0.67			62.0	12.0
MDERAXX080-33V1C	5.68	11.9	12.5	0.69			65.0	16.0
MHERAXX090-13V1C	7.46	17.1	17.9	0.70	73.9	76.4	78.0	15.0
MHERAXX090-33V1C	10.9	25.1	26.2	0.70	76.0	78.5	80.1	17.0
MHERAXX100-33V1C	14.8	31.0	34.1	0.71	79.9	81.0	81.2	22.0
MHERAXX112-23V1C	21.8	49.9	49.9	0.72	81.8	82.8	83.3	25.0
MHERAXX132-13V1C	28.9	69.5	69.5	0.75	81.6	83.4	84.4	34.0
MHERAXX132-23V1C	38.5	92.5	92.5	0.76	83.3	84.2	85.5	43.0
MHERAXX132-33V1C	53.0	133	133	0.76	84.7	86.1	86.9	52.0

► The nameplate only gives rated data for operation at 50 Hz.

Basic MD/MH three-phase AC motors

Technical data



Basic MD/MH three-phase AC motors

Technical data



Dimensions, self-ventilated (2-pole)

Design B3

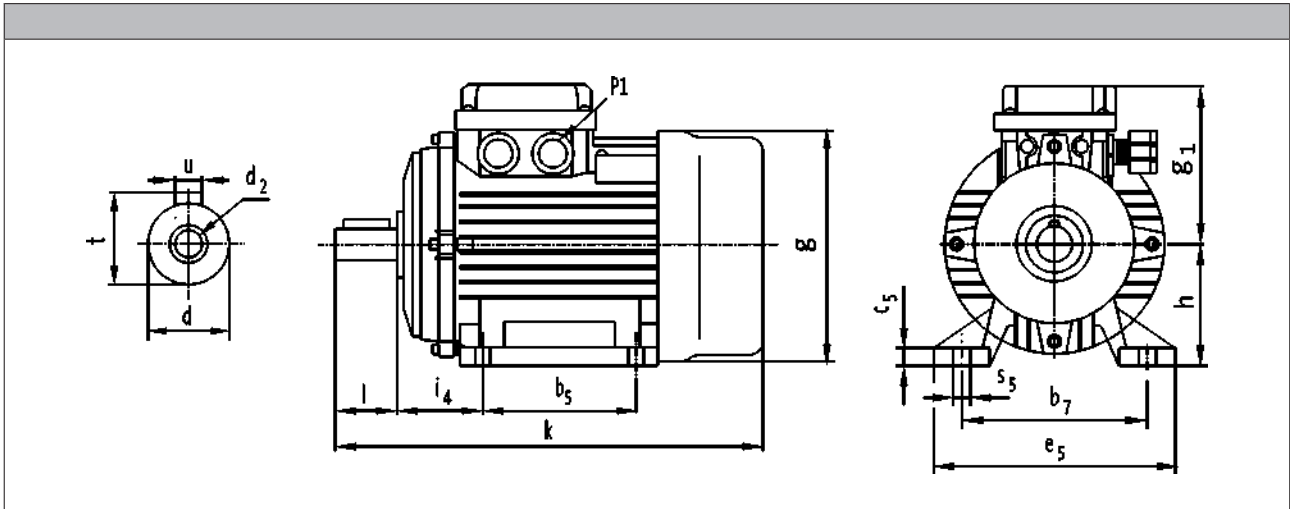

	k [mm]	g [mm]	g ₁ [mm]	P ₁ [mm]
MDERAXX056-11V1C	183	110	96	2x M16x1.5
MDERAXX056-21V1C				
MDERAXX063-11V1C	218	122	99	
MDERAXX063-21V1C				
MDERAXX071-11V1C	251	138	109	2x M20x1.5
MDERAXX071-21V1C				
MHERAXX080-11V1C	315	160	150	2x M24x1.5
MHERAXX080-31V1C				
MHERAXX090-11V1C	320	185	160	
MHERAXX090-31V1C	335			
MHERAXX100-31V1C	390	205	175	
MHERAXX112-21V1C	400	230	185	
MHERAXX132-11V1C	445	265	200	2x M32x1.5
MHERAXX132-21V1C	485			

Basic MD/MH three-phase AC motors

Technical data



Dimensions, self-ventilated (2-pole)

Design B3

	d	d ₂	l	t	u
	j ₆				
	[mm]	[mm]	[mm]	[mm]	[mm]
MDERAXX056-11V1C	9	M4x10	20	10.2	3.0
MDERAXX056-21V1C					
MDERAXX063-11V1C	11		23	12.5	4.0
MDERAXX063-21V1C					
MDERAXX071-11V1C	14	M5x12	30	16.0	5.0
MDERAXX071-21V1C					
MHERAXX080-11V1C	19	M6x16	40	21.5	6.0
MHERAXX080-31V1C					
MHERAXX090-11V1C	24	M8x20	50	27.0	8.0
MHERAXX090-31V1C					
MHERAXX100-31V1C	28	M10x22	60	31.0	
MHERAXX112-21V1C					
MHERAXX132-11V1C	38	M12x28	80	41.0	10.0
MHERAXX132-21V1C					

	b ₇	i ₄	b ₅	e ₅	h	c ₅	s ₅
	[mm]	[mm]	[mm]	[mm]	[mm]	[mm]	[mm]
MDERAXX056-11V1C	90	36	71	110	56	9	7.0
MDERAXX056-21V1C							
MDERAXX063-11V1C	100	40	80	122	63		
MDERAXX063-21V1C							
MDERAXX071-11V1C	112	45	90	136	71	10	
MDERAXX071-21V1C							
MHERAXX080-11V1C	125	50	100	165	80	12	10.0
MHERAXX080-31V1C							
MHERAXX090-11V1C	140	56		125	190		
MHERAXX090-31V1C							
MHERAXX100-31V1C	160	63	140	210	100	14	
MHERAXX112-21V1C	190	70		240	112	15	
MHERAXX132-11V1C	216	89		275	132	18	12.0
MHERAXX132-21V1C							

5.9

Basic MD/MH three-phase AC motors

Technical data



Dimensions, self-ventilated (2-pole)

Design B5

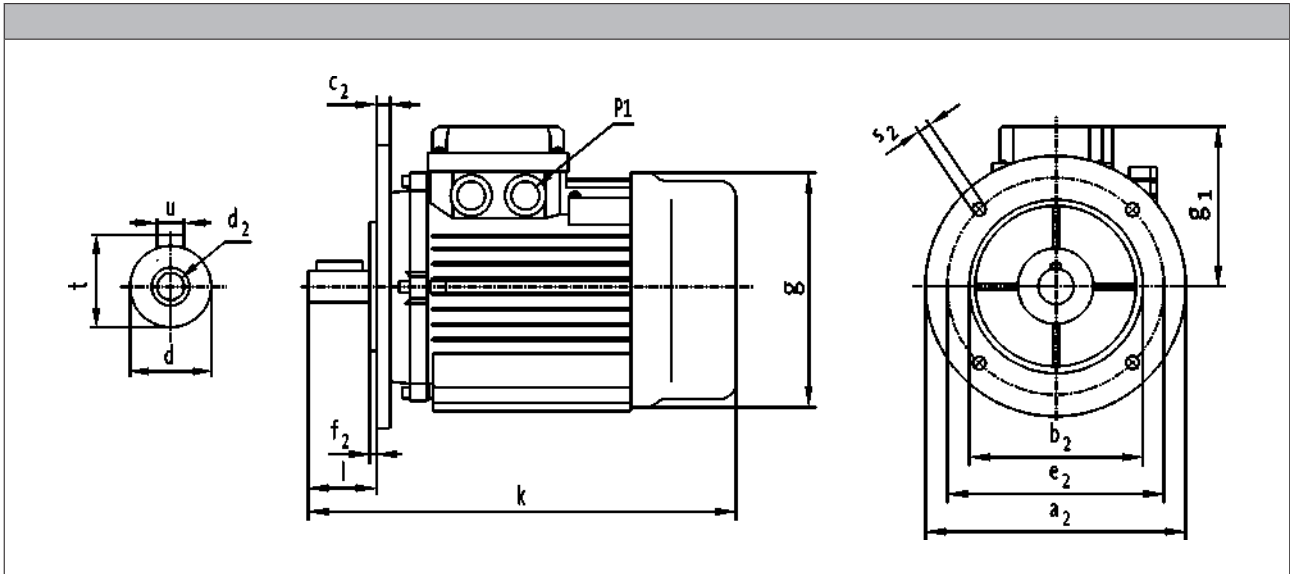

	k [mm]	g [mm]	g ₁ [mm]	P ₁ [mm]
MDERAXX056-11V1C	183	110	96	2x M16x1.5
MDERAXX056-21V1C				
MDERAXX063-11V1C	218	122	99	2x M20x1.5
MDERAXX063-21V1C				
MDERAXX071-11V1C	251	138	109	2x M24x1.5
MDERAXX071-21V1C				
MHERAXX080-11V1C	315	160	150	2x M32x1.5
MHERAXX080-31V1C				
MHERAXX090-11V1C	320	185	160	2x M24x1.5
MHERAXX090-31V1C	335			
MHERAXX100-31V1C	390	205	175	2x M32x1.5
MHERAXX112-21V1C	400	230	185	
MHERAXX132-11V1C	445	265	200	2x M32x1.5
MHERAXX132-21V1C	485			

Basic MD/MH three-phase AC motors



Technical data

Dimensions, self-ventilated (2-pole)

Design B5

	d	d ₂	l	t	u
	j ₆				
	[mm]	[mm]	[mm]	[mm]	[mm]
MDERAXX056-11V1C	9	M4x10	20	10.2	3.0
MDERAXX056-21V1C					
MDERAXX063-11V1C	11		23	12.5	4.0
MDERAXX063-21V1C					
MDERAXX071-11V1C	14	M5x12	30	16.0	5.0
MDERAXX071-21V1C					
MHERAXX080-11V1C	19	M6x16	40	21.5	6.0
MHERAXX080-31V1C					
MHERAXX090-11V1C	24	M8x20	50	27.0	8.0
MHERAXX090-31V1C					
MHERAXX100-31V1C	28	M10x22	60	31.0	
MHERAXX112-21V1C					
MHERAXX132-11V1C	38	M12x28	80	41.0	10.0
MHERAXX132-21V1C					

	a ₂	b ₂	c ₂	e ₂	f ₂	s ₂
		j ₆				
	[mm]	[mm]	[mm]	[mm]	[mm]	[mm]
MDERAXX056-11V1C	120	80	9	100	3.0	7.0
MDERAXX056-21V1C						
MDERAXX063-11V1C	140	95	10	115	3.5	9.0
MDERAXX063-21V1C						
MDERAXX071-11V1C	160	110		130		
MDERAXX071-21V1C						
MHERAXX080-11V1C	200	130	12	165		12.0
MHERAXX080-31V1C						
MHERAXX090-11V1C	250	180	13	215	4.0	15.0
MHERAXX100-31V1C						
MHERAXX112-21V1C	300	230	14	265		
MHERAXX132-11V1C						
MHERAXX132-21V1C						

5.9

Basic MD/MH three-phase AC motors

Technical data



Dimensions, self-ventilated (2-pole)

Design B14

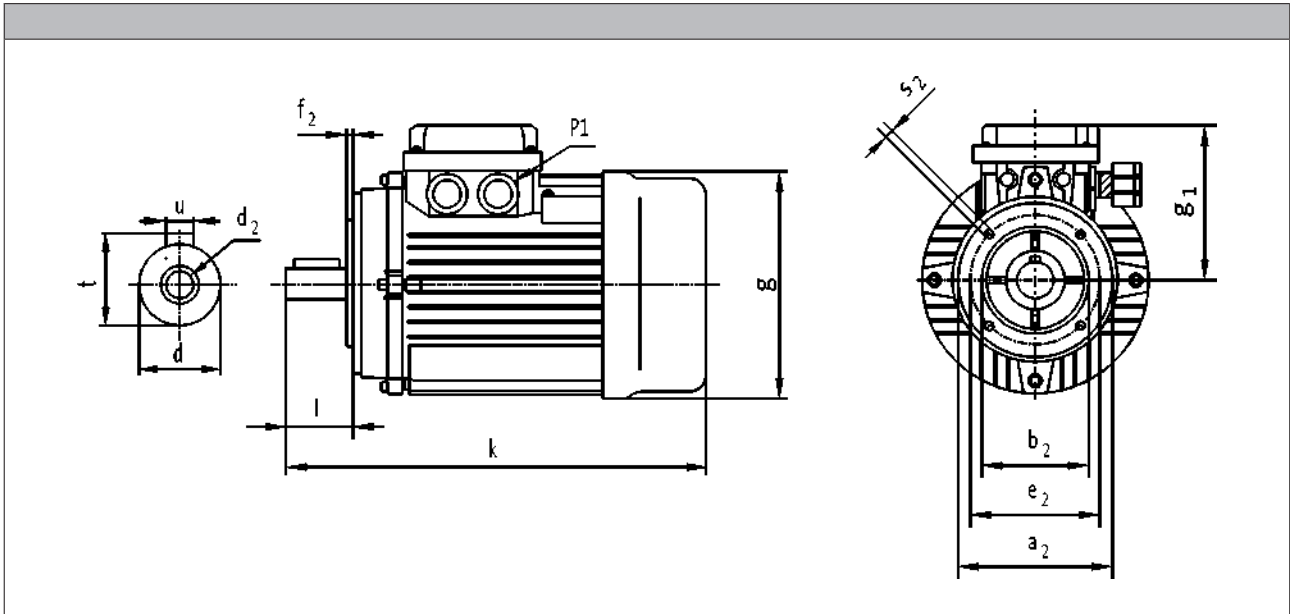

	k	g	g ₁	P ₁
	[mm]	[mm]	[mm]	[mm]
MDERAXX056-11V1C	183	110	96	2x M16x1.5
MDERAXX056-21V1C				
MDERAXX063-11V1C	218	122	99	
MDERAXX063-21V1C				
MDERAXX071-11V1C	251	138	109	2x M20x1.5
MDERAXX071-21V1C				
MHERAXX080-11V1C	315	160	150	2x M24x1.5
MHERAXX080-31V1C				
MHERAXX090-11V1C	320	185	160	
MHERAXX090-31V1C	335			
MHERAXX100-31V1C	390			
MHERAXX112-21V1C	400	230	185	
MHERAXX132-11V1C	445	265	200	2x M32x1.5
MHERAXX132-21V1C				

5.9

Basic MD/MH three-phase AC motors

Technical data



Dimensions, self-ventilated (2-pole)

Design B14

	d	d ₂	l	t	u
	j6				
	[mm]	[mm]	[mm]	[mm]	[mm]
MDERAXX056-11V1C	9	M4x10	20	10.2	3.0
MDERAXX056-21V1C					
MDERAXX063-11V1C	11		23	12.5	4.0
MDERAXX063-21V1C					
MDERAXX071-11V1C	14	M5x12	30	16.0	5.0
MDERAXX071-21V1C					
MHERAXX080-11V1C	19	M6x16	40	21.5	6.0
MHERAXX080-31V1C					
MHERAXX090-11V1C	24	M8x20	50	27.0	8.0
MHERAXX090-31V1C					
MHERAXX100-31V1C	28	M10x22	60	31.0	
MHERAXX112-21V1C					
MHERAXX132-11V1C	38	M12x28	80	41.0	10.0
MHERAXX132-21V1C					

	a ₂	b ₂	e ₂	f ₂	s ₂
	j6				
	[mm]	[mm]	[mm]	[mm]	[mm]
MDERAXX056-11V1C	80	50	65	3.0	8x M5x11
MDERAXX056-21V1C					
MDERAXX063-11V1C	90	60	75		8x M5x14
MDERAXX063-21V1C					
MDERAXX071-11V1C	105	70	85	3.5	8x M6x14
MDERAXX071-21V1C					
MHERAXX080-11V1C	120	80	100	3.0	8x M6x15
MHERAXX080-31V1C					
MHERAXX090-11V1C	140	95	115		8x M8x16
MHERAXX090-31V1C					
MHERAXX100-31V1C	160	110	130	3.5	8x M8x18
MHERAXX112-21V1C					
MHERAXX132-11V1C	200	130	165	4.0	8x M10x23
MHERAXX132-21V1C					

Basic MD/MH three-phase AC motors

Technical data



Dimensions, self-ventilated (4-pole)

Design B3

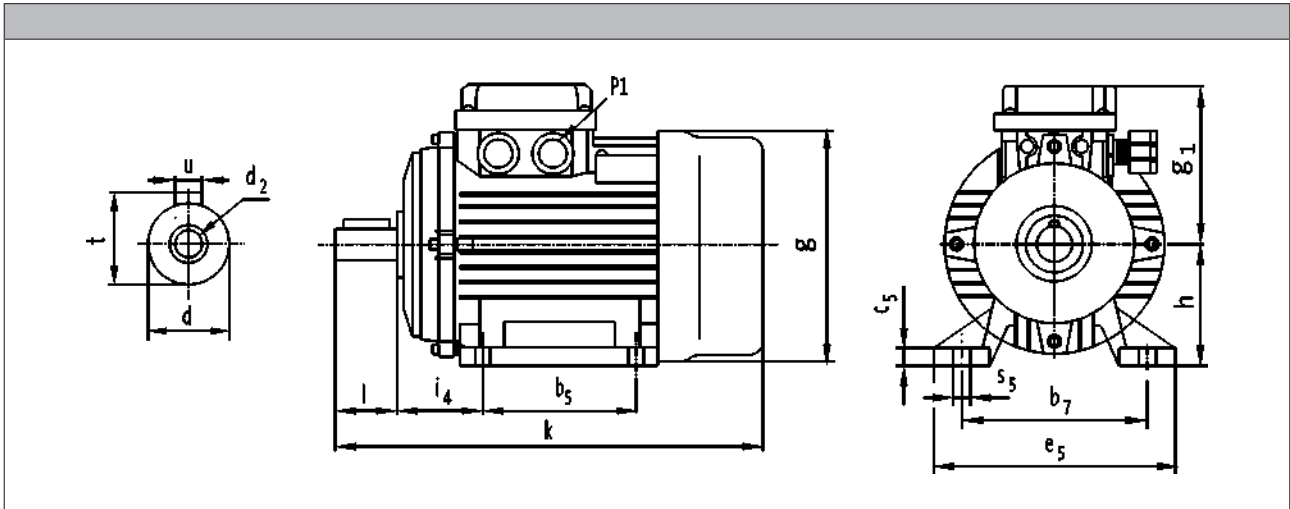

	k [mm]	g [mm]	g ₁ [mm]	P ₁ [mm]
MDERAXX056-12V1C	189	110	96	2x M16x1.5
MDERAXX056-22V1C				
MDERAXX063-12V1C	218	122	99	2x M20x1.5
MDERAXX063-32V1C				
MDERAXX071-12V1C	251	138	109	2x M24x1.5
MDERAXX071-32V1C				
MDERAXX071-42V1C				
MDERAXX080-12V1C	315	160	150	2x M24x1.5
MHERAXX080-32V1C		185		
MHERAXX090-12V1C	320	205	160	2x M24x1.5
MHERAXX090-32V1C	335			
MHERAXX100-12V1C	390	205	175	2x M24x1.5
MHERAXX100-32V1C				

Basic MD/MH three-phase AC motors



Technical data

Dimensions, self-ventilated (4-pole)

Design B3

	d	d ₂	l	t	u
	j ₆				
	[mm]	[mm]	[mm]	[mm]	[mm]
MDERAXX056-12V1C	9	M4x10	20	10.2	3.0
MDERAXX056-22V1C					
MDERAXX063-12V1C	11		23	12.5	4.0
MDERAXX063-32V1C					
MDERAXX071-12V1C	14	M5x12	30	16.0	5.0
MDERAXX071-32V1C					
MDERAXX071-42V1C					
MDERAXX080-12V1C	19	M6x16	40	21.5	6.0
MHERAXX080-32V1C					
MHERAXX090-12V1C	24	M8x20	50	27.0	8.0
MHERAXX090-32V1C					
MHERAXX100-12V1C	28	M10x22	60	31.0	
MHERAXX100-32V1C					

	b ₇	i ₄	b ₅	e ₅	h	c ₅	s ₅
	[mm]	[mm]	[mm]	[mm]	[mm]	[mm]	[mm]
MDERAXX056-12V1C	90	36	71	110	56	9	7.0
MDERAXX056-22V1C							
MDERAXX063-12V1C	100	40	80	122	63		
MDERAXX063-32V1C							
MDERAXX071-12V1C	112	45	90	136	71	10	
MDERAXX071-32V1C							
MDERAXX071-42V1C							
MDERAXX080-12V1C	125	50	100	165	80	12	10.0
MHERAXX080-32V1C							
MHERAXX090-12V1C	140	56		125	190		
MHERAXX090-32V1C							
MHERAXX100-12V1C	160	63	140	210	100	14	12.0
MHERAXX100-32V1C							

5.9

Basic MD/MH three-phase AC motors

Technical data



Dimensions, self-ventilated (4-pole)

Design B3

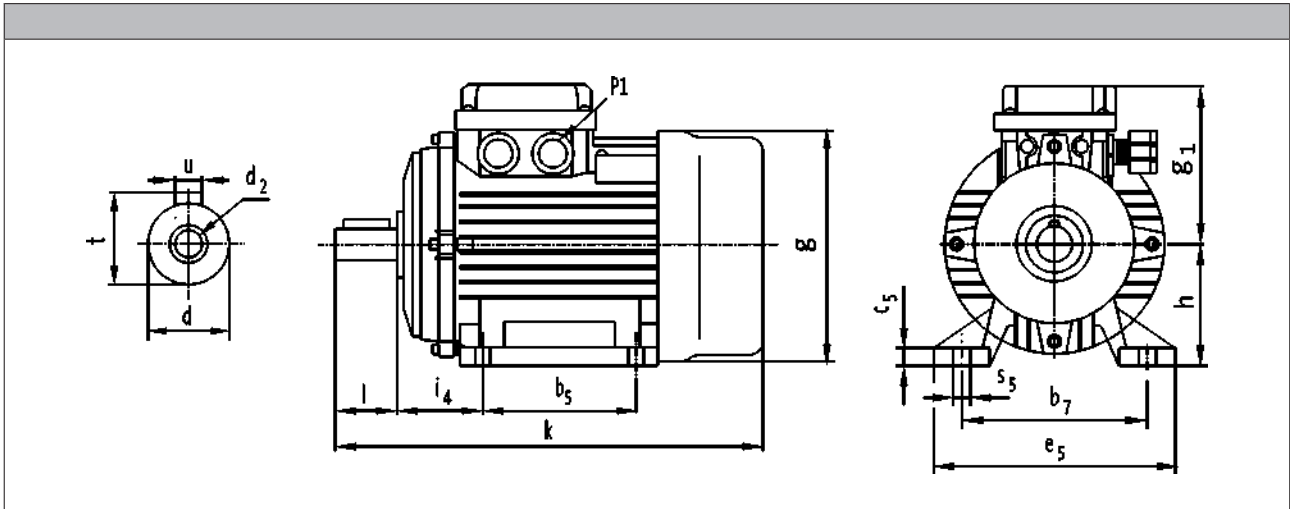

	k	g	g ₁	P ₁
	[mm]	[mm]	[mm]	[mm]
MHERAXX112-22V1C	400	230	185	2x M24×1.5
MHERAXX132-12V1C	445	265	200	2x M32×1.5
MHERAXX132-22V1C				
MHERAXX160-22V1C	605	315	249	2x M40×1.5
MHERAXX160-32V1C	649			
MHERAXX180-22V1C	684	360	265	
MHERAXX180-32V1C	722			
MHERAXX200-32V1C	774	400	292	2x M50×1.5
MHERAXX225-12V1C	821	450	315	
MHERAXX225-22V1C	845			

Basic MD/MH three-phase AC motors

Technical data



Dimensions, self-ventilated (4-pole)

Design B3

	d	d ₂	l	t	u
	j ₆				
	[mm]	[mm]	[mm]	[mm]	[mm]
MHERAXX112-22V1C	28	M10x22	60	31.0	8.0
MHERAXX132-12V1C	38	M12x28	80	41.0	10.0
MHERAXX132-22V1C					
MHERAXX160-22V1C	42	M16x36	110	45.0	12.0
MHERAXX160-32V1C					
MHERAXX180-22V1C	48			51.5	14.0
MHERAXX180-32V1C					
MHERAXX200-32V1C	55	M20x42	140	59.0	16.0
MHERAXX225-12V1C	60			64.0	18.0
MHERAXX225-22V1C					

	b ₇	i ₄	b ₅	e ₅	h	c ₅	s ₅
	[mm]	[mm]	[mm]	[mm]	[mm]	[mm]	[mm]
MHERAXX112-22V1C	190	70	140	240	112	15	12.0
MHERAXX132-12V1C	216	89		178	275	132	
MHERAXX132-22V1C							
MHERAXX160-22V1C	254	108	210	315	160	20	15.0
MHERAXX160-32V1C			254				
MHERAXX180-22V1C	279	121	241	350	180	22	
MHERAXX180-32V1C			279				
MHERAXX200-32V1C	318	133	305	388	200	25	19.0
MHERAXX225-12V1C	356	149	286	435	225	28	
MHERAXX225-22V1C			311				

Basic MD/MH three-phase AC motors

Technical data



Dimensions, self-ventilated (4-pole)

Design B5

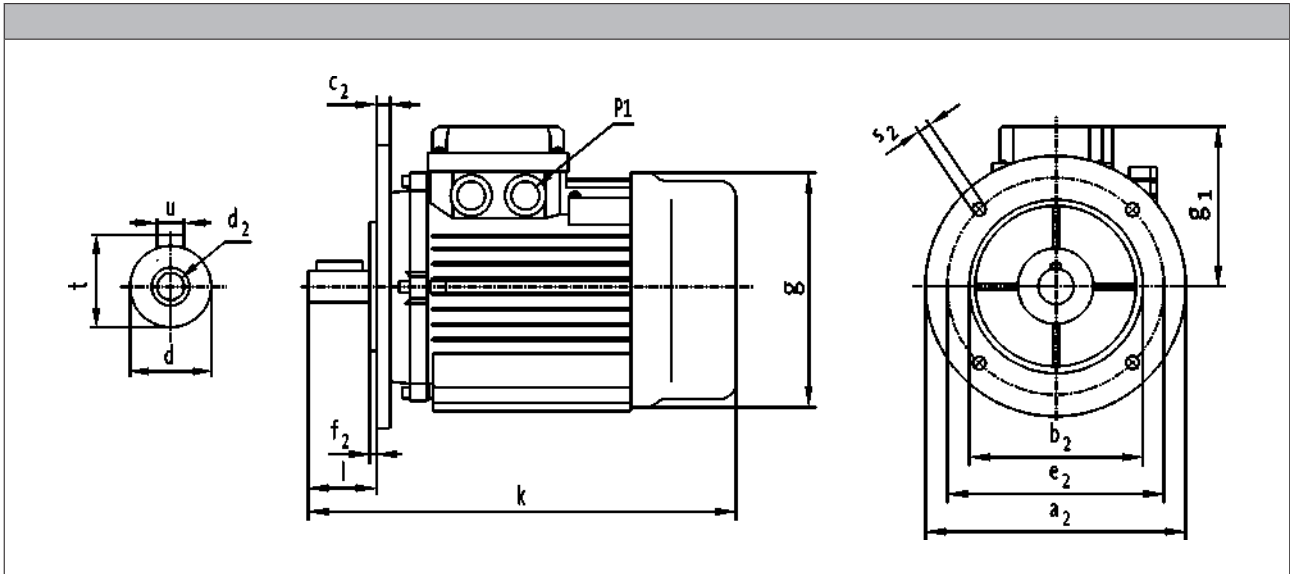

	k [mm]	g [mm]	g ₁ [mm]	P ₁ [mm]
MDERAXX056-12V1C	189	110	96	2x M16x1.5
MDERAXX056-22V1C				
MDERAXX063-12V1C				
MDERAXX063-32V1C	218	122	99	
MDERAXX071-12V1C	251	138	109	2x M20x1.5
MDERAXX071-32V1C				
MDERAXX071-42V1C				
MDERAXX080-12V1C	315	160	150	2x M24x1.5
MHERAXX080-32V1C				
MHERAXX090-12V1C	320	185	160	
MHERAXX090-32V1C	335			
MHERAXX100-12V1C	390			
MHERAXX100-32V1C				

Basic MD/MH three-phase AC motors

Technical data



Dimensions, self-ventilated (4-pole)

Design B5

	d	d ₂	l	t	u
	j ₆				
	[mm]	[mm]	[mm]	[mm]	[mm]
MDERAXX056-12V1C	9	M4x10	20	10.2	3.0
MDERAXX056-22V1C					
MDERAXX063-12V1C	11	M4x10	23	12.5	4.0
MDERAXX063-32V1C					
MDERAXX071-12V1C	14	M5x12	30	16.0	5.0
MDERAXX071-32V1C					
MDERAXX071-42V1C					
MDERAXX080-12V1C	19	M6x16	40	21.5	6.0
MHERAXX080-32V1C					
MHERAXX090-12V1C	24	M8x20	50	27.0	8.0
MHERAXX090-32V1C					
MHERAXX100-12V1C	28	M10x22	60	31.0	
MHERAXX100-32V1C					

	a ₂	b ₂	c ₂	e ₂	f ₂	s ₂
		j ₆				
	[mm]	[mm]	[mm]	[mm]	[mm]	[mm]
MDERAXX056-12V1C	120	80	9	100	3.0	7.0
MDERAXX056-22V1C						
MDERAXX063-12V1C	140	95	10	115	3.5	9.0
MDERAXX063-32V1C						
MDERAXX071-12V1C	160	110	12	130	4.0	12.0
MDERAXX071-32V1C						
MDERAXX071-42V1C						
MDERAXX080-12V1C	200	130	12	165	4.0	15.0
MHERAXX080-32V1C						
MHERAXX090-12V1C	250	180	13	215	4.0	15.0
MHERAXX090-32V1C						
MHERAXX100-12V1C	250	180	13	215	4.0	15.0
MHERAXX100-32V1C						

5.9

Basic MD/MH three-phase AC motors

Technical data



Dimensions, self-ventilated (4-pole)

Design B5

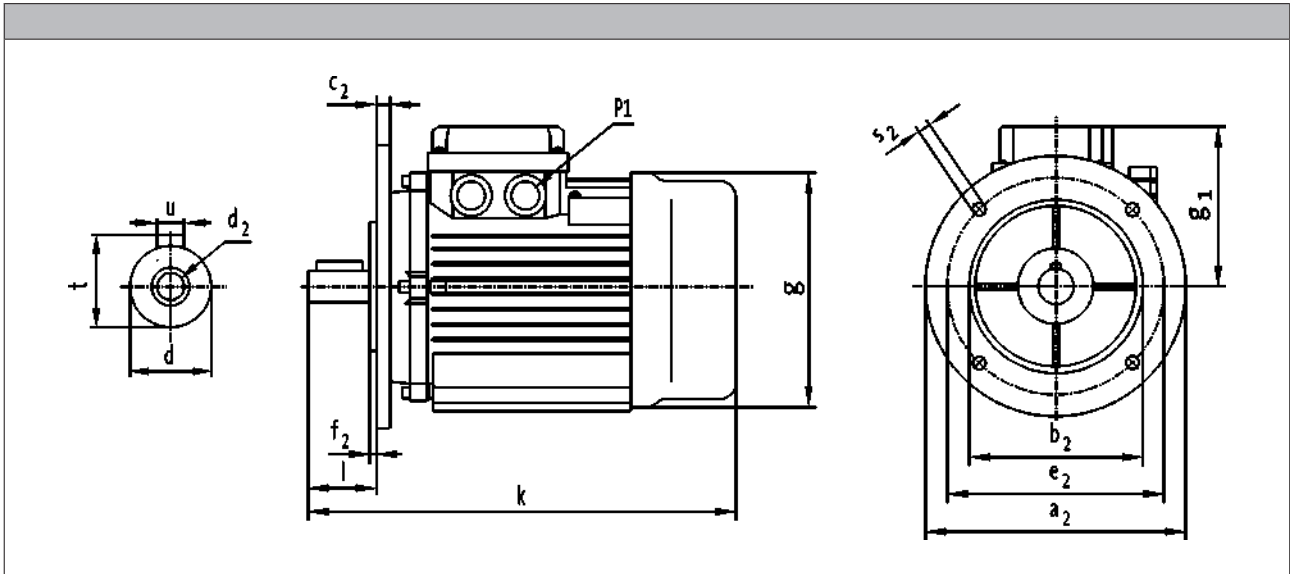

	k	g	g ₁	P ₁
	[mm]	[mm]	[mm]	[mm]
MHERAXX112-22V1C	400	230	185	2x M24×1.5
MHERAXX132-12V1C	445	265	200	2x M32×1.5
MHERAXX132-22V1C				
MHERAXX160-22V1C	605	315	249	2x M40×1.5
MHERAXX160-32V1C	649			
MHERAXX180-22V1C	684	360	265	
MHERAXX180-32V1C	722			
MHERAXX200-32V1C	774	400	292	2x M50×1.5
MHERAXX225-12V1C	821	450	315	
MHERAXX225-22V1C	845			

Basic MD/MH three-phase AC motors

Technical data



Dimensions, self-ventilated (4-pole)

Design B5

	d	d ₂	l	t	u
	j6				
	[mm]	[mm]	[mm]	[mm]	[mm]
MHERAXX112-22V1C	28	M10x22	60	31.0	8.0
MHERAXX132-12V1C	38	M12x28	80	41.0	10.0
MHERAXX132-22V1C					
MHERAXX160-22V1C	42	M16x36	110	45.0	12.0
MHERAXX160-32V1C					
MHERAXX180-22V1C	48			51.5	14.0
MHERAXX180-32V1C					
MHERAXX200-32V1C	55	M20x42	140	59.0	16.0
MHERAXX225-12V1C	60			64.0	18.0
MHERAXX225-22V1C					

	a ₂	b ₂	c ₂	e ₂	f ₂	s ₂
	j6					
	[mm]	[mm]	[mm]	[mm]	[mm]	[mm]
MHERAXX112-22V1C	250	180	14	215	4.0	15.0
MHERAXX132-12V1C	300	230		265		
MHERAXX132-22V1C						
MHERAXX160-22V1C	350	250	15	300	5.0	19.0
MHERAXX160-32V1C						
MHERAXX180-22V1C						
MHERAXX180-32V1C						
MHERAXX200-32V1C	400	300	17	350	5.0	19.0
MHERAXX225-12V1C	450	350	20	400		
MHERAXX225-22V1C						

Basic MD/MH three-phase AC motors

Technical data



Dimensions, self-ventilated (4-pole)

Design B14

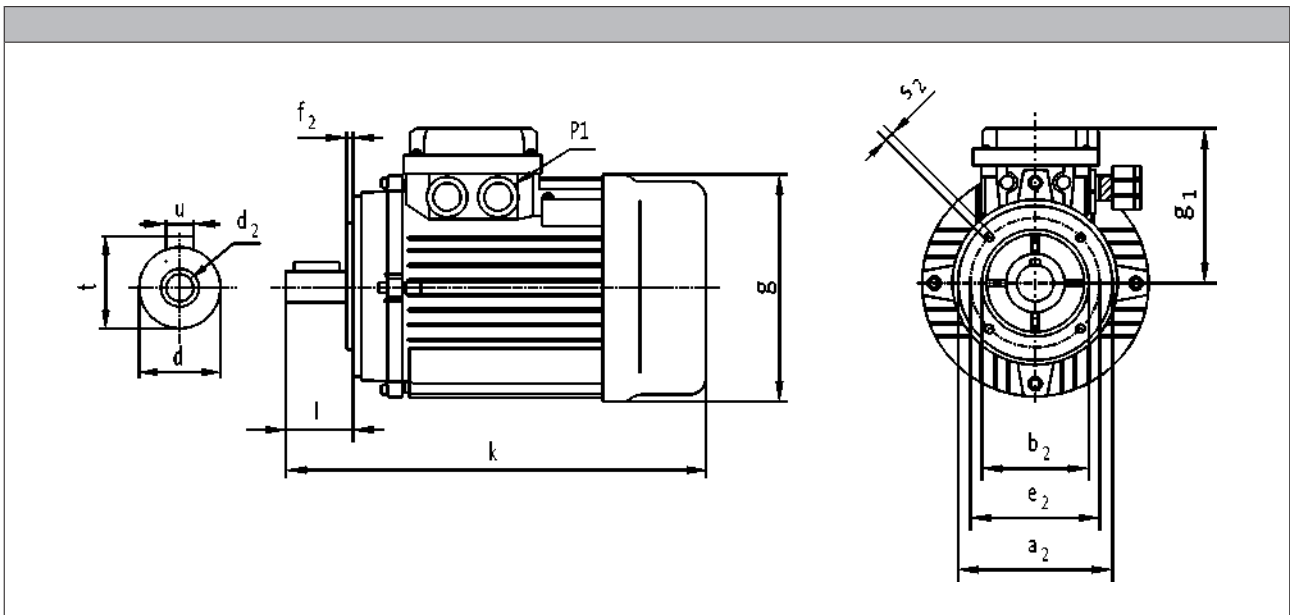

	k	g	g ₁	P ₁
	[mm]	[mm]	[mm]	[mm]
MDERAXX056-12V1C	189	110	96	2x M16x1.5
MDERAXX056-22V1C				
MDERAXX063-12V1C				
MDERAXX063-32V1C	218	122	99	
MDERAXX071-12V1C	251	138	109	2x M20x1.5
MDERAXX071-32V1C				
MDERAXX071-42V1C				
MDERAXX080-12V1C	315	160	150	2x M24x1.5
MHERAXX080-32V1C				
MHERAXX090-12V1C				
MHERAXX090-32V1C	320	185	160	
MHERAXX100-12V1C	335			
MHERAXX100-32V1C	390	205	175	
MHERAXX112-22V1C	400	230	185	
MHERAXX132-12V1C	445	265	200	2x M32x1.5
MHERAXX132-22V1C				

Basic MD/MH three-phase AC motors

Technical data



Dimensions, self-ventilated (4-pole)

Design B14

	d	d ₂	l	t	u
	j6				
	[mm]	[mm]	[mm]	[mm]	[mm]
MDERAXX056-12V1C	9	M4x10	20	10.2	3.0
MDERAXX056-22V1C					
MDERAXX063-12V1C	11		23	12.5	4.0
MDERAXX063-32V1C					
MDERAXX071-12V1C	14	M5x12	30	16.0	5.0
MDERAXX071-32V1C					
MDERAXX071-42V1C					
MDERAXX080-12V1C	19	M6x16	40	21.5	6.0
MHERAXX080-32V1C					
MHERAXX090-12V1C	24	M8x20	50	27.0	8.0
MHERAXX090-32V1C					
MHERAXX100-12V1C	28	M10x22	60	31.0	
MHERAXX100-32V1C					
MHERAXX112-22V1C	38	M12x28	80	41.0	10.0
MHERAXX132-12V1C					
MHERAXX132-22V1C					

	a ₂	b ₂	e ₂	f ₂	s ₂	
	j6					
	[mm]	[mm]	[mm]	[mm]	[mm]	
MDERAXX056-12V1C	80	50	65	3.0	8x M5x11	
MDERAXX056-22V1C						
MDERAXX063-12V1C	90	60	75		8x M5x14	
MDERAXX063-32V1C						
MDERAXX071-12V1C	105	70	85	3.5	8x M6x14	
MDERAXX071-32V1C						
MDERAXX071-42V1C						
MDERAXX080-12V1C	120	80	100	3.0	8x M6x16	
MHERAXX080-32V1C						8x M6x15
MHERAXX090-12V1C	140	95	115		8x M8x16	
MHERAXX090-32V1C						
MHERAXX100-12V1C	160	110	130	3.5	8x M8x18	
MHERAXX100-32V1C						8x M8x19
MHERAXX112-22V1C						
MHERAXX132-12V1C	200	130	165	4.0	8x M10x23	
MHERAXX132-22V1C						

5.9

Basic MD/MH three-phase AC motors

Technical data



Dimensions, self-ventilated (6-pole)

Design B3

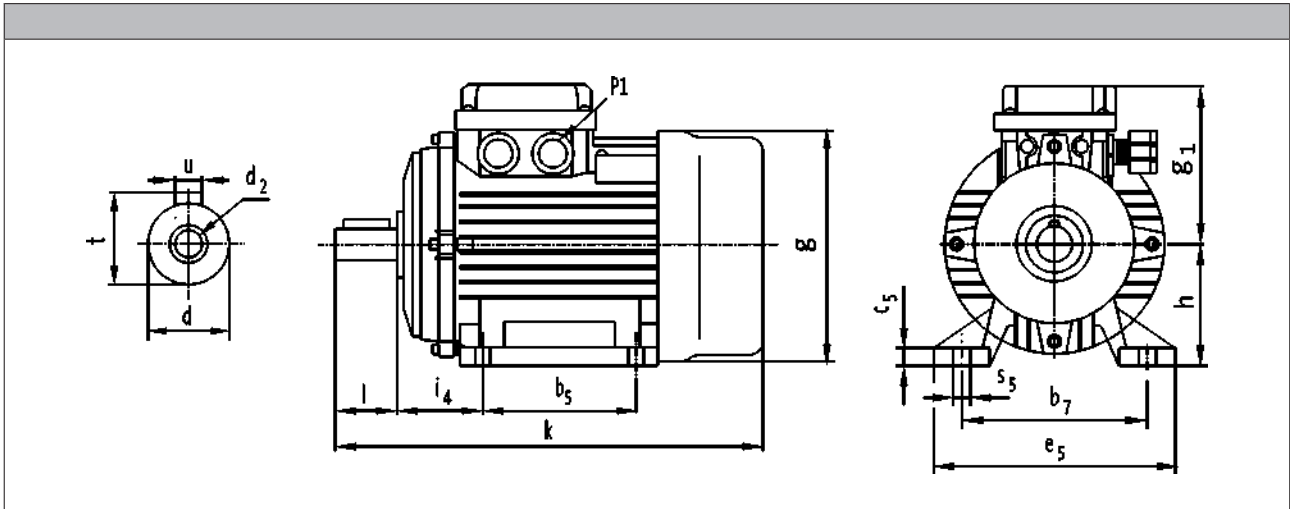

	k [mm]	g [mm]	g ₁ [mm]	P ₁ [mm]
MDERAXX063-13V1C	218	122	99	2x M16x1.5
MDERAXX063-23V1C				
MDERAXX071-13V1C	251	138	109	2x M20x1.5
MDERAXX071-23V1C				
MDERAXX080-23V1C	286	157	112	2x M24x1.5
MDERAXX080-33V1C				
MHERAXX090-13V1C	320	185	160	
MHERAXX090-33V1C	335			
MHERAXX100-33V1C	390	205	175	
MHERAXX112-23V1C	400	230	185	
MHERAXX132-13V1C	445	265	200	2x M32x1.5
MHERAXX132-23V1C	485			
MHERAXX132-33V1C				

Basic MD/MH three-phase AC motors



Technical data

Dimensions, self-ventilated (6-pole)

Design B3

	d	d ₂	l	t	u
	j6				
	[mm]	[mm]	[mm]	[mm]	[mm]
MDERAXX063-13V1C	11	M4x10	23	12.5	4.0
MDERAXX063-23V1C					
MDERAXX071-13V1C	14	M5x12	30	16.0	5.0
MDERAXX071-23V1C					
MDERAXX080-23V1C	19	M6x16	40	21.5	6.0
MDERAXX080-33V1C					
MHERAXX090-13V1C	24	M8x20	50	27.0	8.0
MHERAXX090-33V1C					
MHERAXX100-33V1C	28	M10x22	60	31.0	
MHERAXX112-23V1C					
MHERAXX132-13V1C	38	M12x28	80	41.0	10.0
MHERAXX132-23V1C					
MHERAXX132-33V1C					

	b ₇	i ₄	b ₅	e ₅	h	c ₅	s ₅
	[mm]	[mm]	[mm]	[mm]	[mm]	[mm]	[mm]
MDERAXX063-13V1C	100	40	80	122	63	9	7.0
MDERAXX063-23V1C							
MDERAXX071-13V1C	112	45	90	136	71	10	
MDERAXX071-23V1C							
MDERAXX080-23V1C	125	50	100	154	80	12	10.0
MDERAXX080-33V1C							
MHERAXX090-13V1C	140	56		125	190		
MHERAXX090-33V1C							
MHERAXX100-33V1C	160	63	140	210	100	14	12.0
MHERAXX112-23V1C							
MHERAXX132-13V1C	190	70		140	240	112	
MHERAXX132-23V1C							
MHERAXX132-33V1C			216	89	178	275	132

5.9

Basic MD/MH three-phase AC motors

Technical data



Dimensions, self-ventilated (6-pole)

Design B5

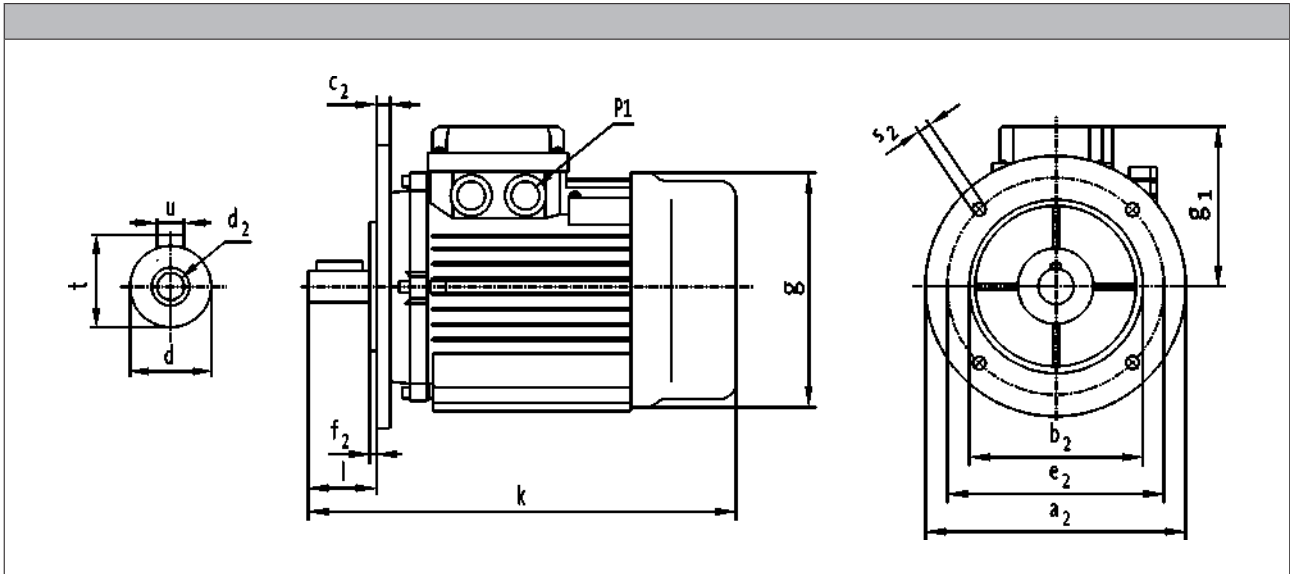

	k [mm]	g [mm]	g ₁ [mm]	P ₁ [mm]
MDERAXX063-13V1C	218	122	99	2x M16x1.5
MDERAXX063-23V1C				
MDERAXX071-13V1C	251	138	109	2x M20x1.5
MDERAXX071-23V1C				
MDERAXX080-23V1C	286	157	112	2x M24x1.5
MDERAXX080-33V1C				
MHERAXX090-13V1C	320	185	160	
MHERAXX090-33V1C	335			
MHERAXX100-33V1C	390	205	175	
MHERAXX112-23V1C	400	230	185	
MHERAXX132-13V1C	445	265	200	2x M32x1.5
MHERAXX132-23V1C	485			
MHERAXX132-33V1C				

Basic MD/MH three-phase AC motors

Technical data



Dimensions, self-ventilated (6-pole)

Design B5

	d	d ₂	l	t	u
	j ₆				
	[mm]	[mm]	[mm]	[mm]	[mm]
MDERAXX063-13V1C	11	M4x10	23	12.5	4.0
MDERAXX063-23V1C					
MDERAXX071-13V1C	14	M5x12	30	16.0	5.0
MDERAXX071-23V1C					
MDERAXX080-23V1C	19	M6x16	40	21.5	6.0
MDERAXX080-33V1C					
MHERAXX090-13V1C	24	M8x20	50	27.0	8.0
MHERAXX090-33V1C					
MHERAXX100-33V1C	28	M10x22	60	31.0	
MHERAXX112-23V1C					
MHERAXX132-13V1C	38	M12x28	80	41.0	10.0
MHERAXX132-23V1C					
MHERAXX132-33V1C					

	a ₂	b ₂	c ₂	e ₂	f ₂	s ₂
		j ₆				
	[mm]	[mm]	[mm]	[mm]	[mm]	[mm]
MDERAXX063-13V1C	140	95	10	115	3.0	9.0
MDERAXX063-23V1C						
MDERAXX071-13V1C	160	110				
MDERAXX071-23V1C						
MDERAXX080-23V1C	200	130	12	165	3.5	12.0
MDERAXX080-33V1C						
MHERAXX090-13V1C	250	180				
MHERAXX090-33V1C						
MHERAXX100-33V1C	250	180	13	215	4.0	15.0
MHERAXX112-23V1C						
MHERAXX132-13V1C	300	230	14	265		
MHERAXX132-23V1C						
MHERAXX132-33V1C						

Basic MD/MH three-phase AC motors

Technical data



Dimensions, self-ventilated (6-pole)

Design B14

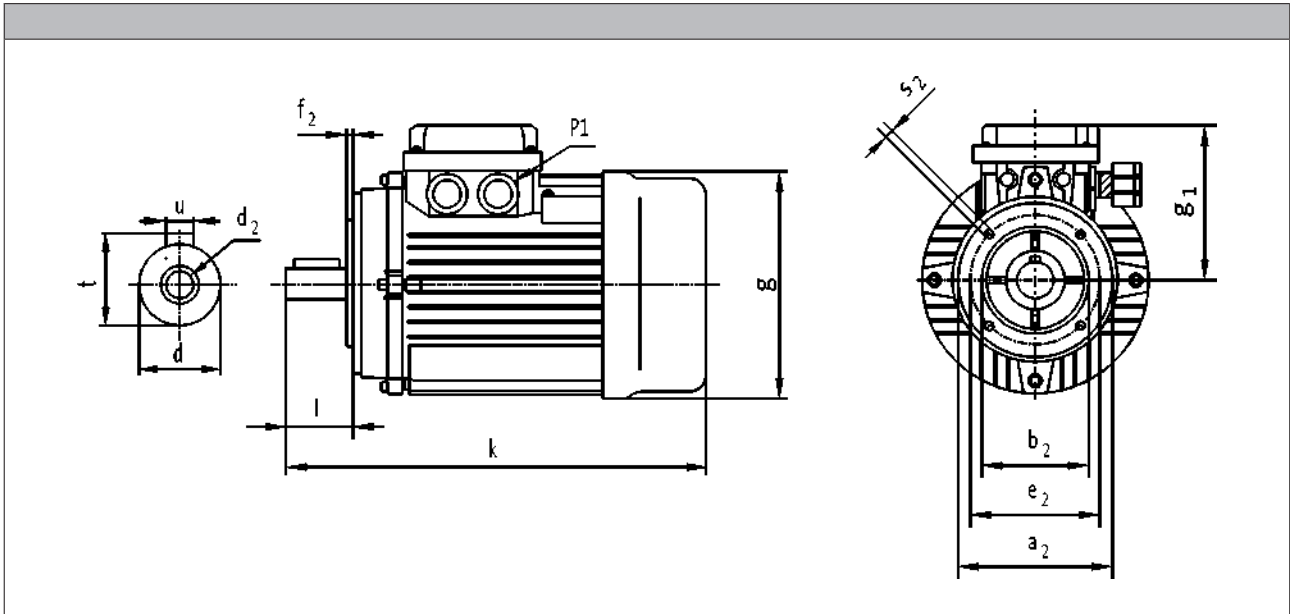

	k [mm]	g [mm]	g ₁ [mm]	P ₁ [mm]
MDERAXX063-13V1C	218	122	99	2x M16x1.5
MDERAXX063-23V1C				
MDERAXX071-13V1C	251	138	109	2x M20x1.5
MDERAXX071-23V1C				
MDERAXX080-23V1C	286	157	112	2x M24x1.5
MDERAXX080-33V1C				
MHERAXX090-13V1C	320	185	160	
MHERAXX090-33V1C	335			
MHERAXX100-33V1C	390	205	175	
MHERAXX112-23V1C	400	230	185	
MHERAXX132-13V1C	445	265	200	2x M32x1.5
MHERAXX132-23V1C	485			
MHERAXX132-33V1C				

Basic MD/MH three-phase AC motors



Technical data

Dimensions, self-ventilated (6-pole)

Design B14

	d	d ₂	l	t	u
	j6				
	[mm]	[mm]	[mm]	[mm]	[mm]
MDERAXX063-13V1C	11	M4x10	23	12.5	4.0
MDERAXX063-23V1C					
MDERAXX071-13V1C	14	M5x12	30	16.0	5.0
MDERAXX071-23V1C					
MDERAXX080-23V1C	19	M6x16	40	21.5	6.0
MDERAXX080-33V1C					
MHERAXX090-13V1C	24	M8x20	50	27.0	8.0
MHERAXX090-33V1C					
MHERAXX100-33V1C	28	M10x22	60	31.0	
MHERAXX112-23V1C					
MHERAXX132-13V1C	38	M12x28	80	41.0	10.0
MHERAXX132-23V1C					
MHERAXX132-33V1C					

	a ₂	b ₂	e ₂	f ₂	s ₂
		j6			
	[mm]	[mm]	[mm]	[mm]	[mm]
MDERAXX063-13V1C	90	60	75	3.0	8x M5x14
MDERAXX063-23V1C					
MDERAXX071-13V1C	105	70	85	3.5	8x M6x14
MDERAXX071-23V1C					
MDERAXX080-23V1C	120	80	100		8x M6x15
MDERAXX080-33V1C					
MHERAXX090-13V1C	140	95	115	3.0	8x M8x16
MHERAXX090-33V1C					
MHERAXX100-33V1C	160	110	130	3.5	8x M8x18
MHERAXX112-23V1C					8x M8x19
MHERAXX132-13V1C	200	130	165		4.0
MHERAXX132-23V1C					
MHERAXX132-33V1C					

5.9

Basic MD/MH three-phase AC motors

Technical data



Basic MD/MH three-phase AC motors

Technical data



Basic MD/MH three-phase AC motors

Technical data



15593807

Lenze SE
Hans-Lenze-Straße 1
D-31855 Aerzen
Phone: +49 (0)5154 82-0
Telefax: +49 (0)5154 82 28 00

www.Lenze.com

Lenze