

Modular Units: MDU, MOU, MBU, and MIU
Modular Combinations: MDO, MDB, MIDO,
MIDB, and MIB



Models: 625 & 875



In accordance with Nexen's established policy of constant product improvement, the specifications contained in this manual are subject to change without notice. Technical data listed in this manual are based on the latest information available at the time of printing and are also subject to change without notice.

Technical Support: 800-843-7445
(651) 484-5900

www.nexengroup.com

	<p style="text-align: center;"> DANGER</p> <p>Read this manual carefully before installation and operation. Follow Nexen's instructions and integrate this unit into your system with care. This unit should be installed, operated and maintained by qualified personnel ONLY. Improper installation can damage your system, cause injury or death. Comply with all applicable codes.</p>	
---	---	---

This document is the original, non-translated, version.

Conformity Declaration: In accordance with Appendix II B of CE Machinery Directive (2006/42/EC):

A Declaration of Incorporation of Partly Completed Machinery evaluation for the applicable EU directives was carried out for this product in accordance with the Machinery Directive. The declaration of incorporation is set out in writing in a separate document and can be requested if required.

This machinery is incomplete and must not be put into service until the machinery into which it is to be incorporated has been declared in conformity with the applicable provisions of the Directive.

Nexen Group, Inc.
560 Oak Grove Parkway
Vadnais Heights, Minnesota 55127

ISO 9001 Certified

Table of Contents

General Specifications	4
General Safety Precautions	4
Connecting Units to Form Combinations	5
Mounting Modular Brake Units	7
Housing Guard Installation	8
Mounting Modular Units onto Mounting Feet	8
Lubrication	9
Air Connections	9
Operation	10
Troubleshooting	11
Parts Replacement	12
Replacement Parts	16
Accessories	20
Warranty	21

GENERAL SPECIFICATIONS

Specifications	
Torque:	Clutch: Up to 48 Nm (425 in-lbs) Brake: Up to 62 Nm (550 in-lbs)
Actuation Pressure:	1 - 5.5 bar (14.5 - 80 psi)
Service Temperature:	4.5 - 104 C (40 - 220 F)
Approximate Weight:	Up to 20.4 kg (45 lbs)

GENERAL SAFETY PRECAUTIONS



CAUTION

Use lifting aids and proper lifting techniques when installing, removing, or placing this product in service.



WARNING

Ensure proper guarding of the product is used. Nexen recommends the machine builder design guarding in compliance with OSHA 29 CFR 1910 "Occupational Safety and Health Hazards".



CAUTION

This product has possible pinch points. Care should be taken when interacting with this product.



CAUTION

Use appropriate guarding for moving components. Failure to guard could result in serious bodily injury.



WARNING

This product is capable of emitting a spark if misused therefore is not recommended for use in any explosive environment.



CAUTION

Watch for sharp features when interacting with this product. The parts have complex shapes and machined edges.

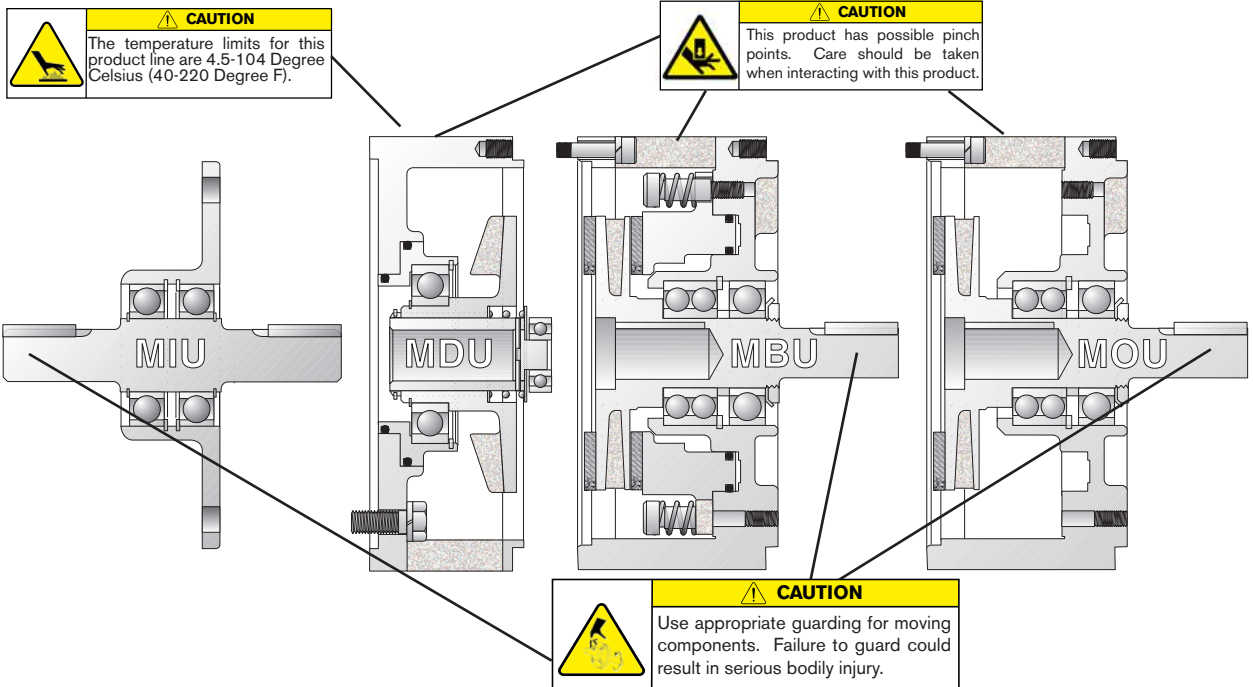

CAUTION

The temperature limits for this product line are 4.5-104 Degree Celsius (40-220 Degree F).

CAUTION

This product has possible pinch points. Care should be taken when interacting with this product.

CAUTION

Use appropriate guarding for moving components. Failure to guard could result in serious bodily injury.

CONNECTING UNITS TO FORM COMBINATIONS

MODULAR CLUTCH (MDO)

Refer to Figure 1.

NOTE
The Modular Drive Unit (MDU) Ball Bearing (Item 27) is loose fitting by design. Do not allow this Ball Bearing to fall off the MDU.

1. Place the Modular Drive Unit (MDU) on a table with the Ball Bearing (Item 27) facing up and properly seated against the Retaining Ring on Models 625 and 875.
2. Set the Modular Output Unit (MOU) onto the MDU, making sure the Ball Bearing (Item 27) is fully seated into the bore of the MOU.
3. Rotate the MOU until the four clearance holes are aligned with the four MDU tapped holes.
4. Press the MOU down against the Compression Spring (Item 14) until faces of both units are flush.

	CAUTION
Never substitute Hex. Head Cap Screws for the Socket Head Cap Screws (Item 31).	

NOTE
Make sure the air inlet ports are properly aligned for your mounting requirements.

MODULAR CLUTCH-BRAKE (MDB)

Refer to Figure 2.

NOTE
The Modular Drive Unit (MDU) Ball Bearing (Item 27) is loose fitting by design. Do not allow this Ball Bearing to fall off the MDU.

1. Place the Modular Drive Unit (MDU) on a table with the Ball Bearing (Item 27) facing up and properly seated against the Retaining Ring on Models 625 and 875.
2. Set the Modular Brake Unit (MBU) onto the MDU, making sure the Ball Bearing (Item 27) is fully seated into the bore of the MBU.
3. Rotate the MBU until the four clearance holes are aligned with the four tapped holes in the MDU.
4. Press the MBU down against the Compression Spring (Item 14) until the faces of both units are flush.

	CAUTION
Never substitute Hex. Head Cap Screws for the Socket Head Cap Screws (Item 31).	

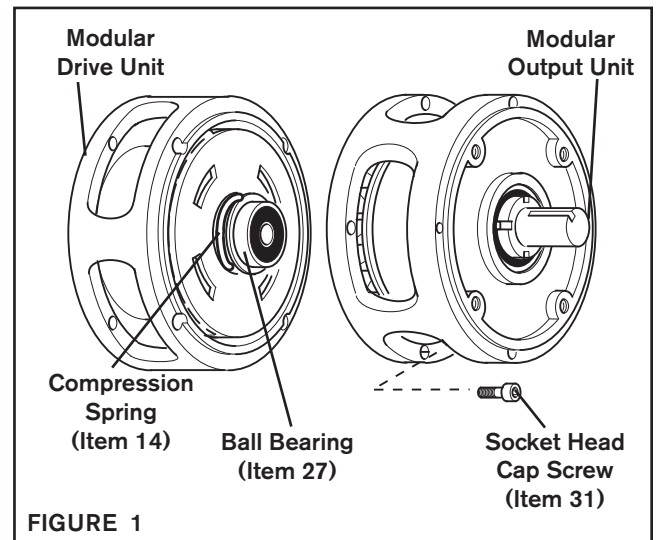

FIGURE 1

5. Using the four Socket Head Cap Screws (Item 31), secure the MOU to the MDU.
6. Alternately and evenly tighten the four Socket Head Cap Screws (Item 31) to 35 ft-lb [47 Nm] torque.

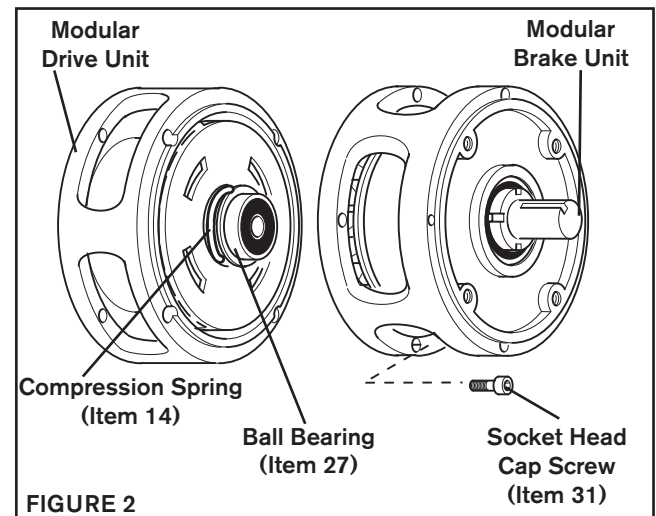

FIGURE 2

NOTE
Make sure the air inlet ports are properly aligned for your MBU mounting requirements.

5. Using the four Socket Head Cap Screws (Item 31), secure the MBU to the MDU.
6. Alternately and evenly tighten the four Socket Head Cap Screws (Item 31) to 35 ft-lb [47 Nm] torque.

CONNECTING UNITS TO FORM COMBINATIONS (continued...)

MODULAR INPUT CLUTCH (MIDO)

Refer to Figure 3.

NOTE
The Modular Drive Unit (MDU) Ball Bearing (Item 27) is loose fitting by design. Do not allow this Ball Bearing to fall off the MDU.

1. Place the Modular Drive Unit (MDU) on a table with the Ball Bearing (Item 27) facing up and properly seated against the Retaining Ring on Models 625 and 875.
2. Set the Modular Output Unit (MOU) onto the MDU, making sure the Ball Bearing (Item 27) is fully seated into the bore of the MOU.
3. Rotate the MOU until the four clearance holes are aligned with the four MDU tapped holes.
4. Press the MOU down against the Compression Spring (Item 14) until the faces of both units are flush.

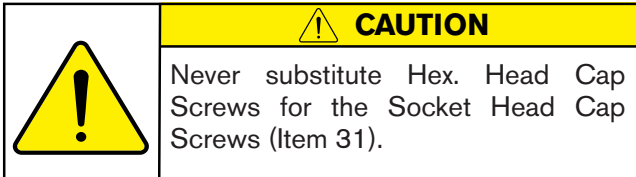

NOTE
Make sure the air inlet ports are properly aligned for your mounting requirements.

5. Using the four Socket Head Cap Screws (Item 31), secure the MOU to the MDU.
6. Alternately and evenly tighten the four Socket Head Cap Screws (Item 31) to 35 ft-lb [47 Nm] torque.

MODULAR INPUT CLUTCH-BRAKE (MIDB)

Refer to Figure 4.

NOTE
The Modular Drive Unit (MDU) Ball Bearing (Item 27) is loose fitting by design. Do not allow this Ball Bearing to fall off the MDU.

1. Place the Modular Drive Unit (MDU) on a table with the Ball Bearing (Item 27) facing up and properly seated against the Retaining Ring on Models 625 and 875.
2. Set the Modular Brake Unit (MBU) onto the MDU, making sure the Ball Bearing (Item 27) is fully seated into the bore of the MBU.
3. Rotate the MBU until the four clearance holes are aligned with the four MDU tapped holes.
4. Press the MBU down against the Compression Spring (Item 14) until the faces of both units are flush.

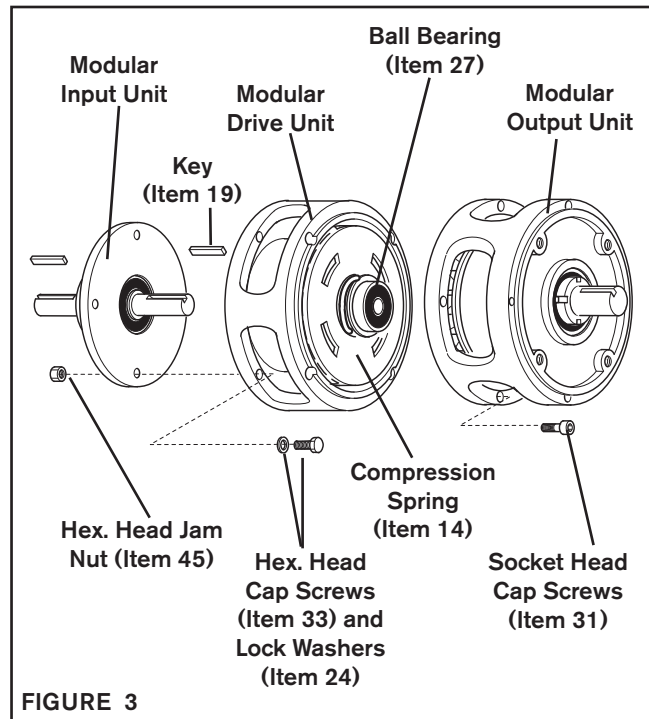

FIGURE 3

7. Place the Key (Item 19) into the shaft of the Modular Input Unit (MIU); then, slide the MIU shaft into the MDU.
8. Using the four Hex. Head Jam Nuts (Item 45), Hex. Head Cap Screws (Item 33), and Lock Washers (Item 24), secure the MIU to the MDU.
9. Alternately and evenly tighten the four Hex. Head Jam Nuts (Item 45) to 20 ft-lb [27 Nm] torque.

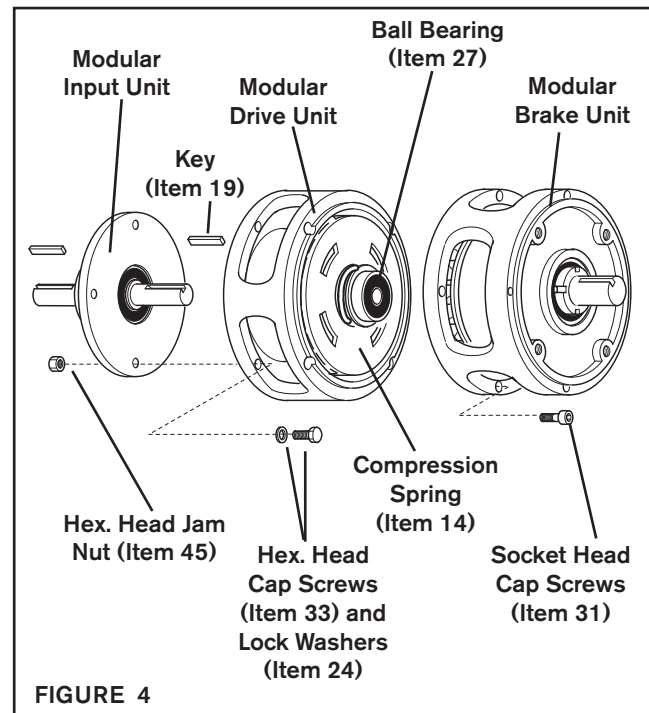
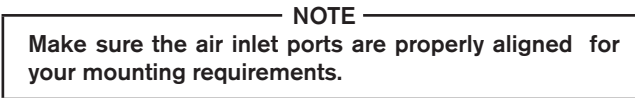
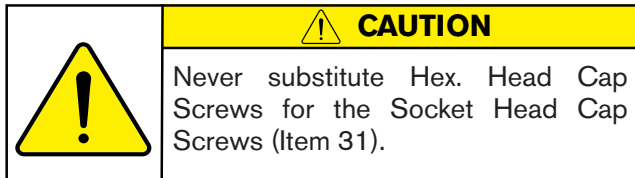

FIGURE 4

(continued...)

CONNECTING UNITS TO FORM COMBINATIONS (continued...)



- Using the four Socket Head Cap Screws (Item 31), secure the MBU to the MDU (See Figure 4).
- Alternately and evenly tighten the four Socket Head Cap Screws (Item 31) to 35 ft-lb [47 Nm] torque (See Figure 4).
- Place the Key (Item 19) into the shaft of the Modular Input Unit (MIU). Slide the MIU shaft into MDU (See Figure 4).
- Using the four Hex. Head Jam Nuts (Item 45), Hex. Head Cap Screws (Item 33), and Lock Washers (Item 24), secure the MIU to the MDU (See Figure 4).
- Alternately and evenly tighten the four Hex. Head Jam Nuts (Item 45) to 20 ft-lb [27 Nm] torque (See Figure 4).

Models 625 and 875

- Remove the six Machine Screws (Item 25) that secure the Friction Facing (Item 9) to the MBU Disc Journal (Item 8) and save the Machine Screws and Friction Facing as spare parts (See Figure 5).
- Place the Key (Item 19) into the shaft of the Modular Input Unit (MIU); then, slide the MIU shaft into the Modular Brake Unit (MBU) (See Figure 5).
- Using the four Hex. Head Jam Nuts (Item 45), Hex. Head Cap Screws (Item 33), and Lock Washers (Item 24), secure the MIU to the MBU (See Figure 5).
- Alternately and evenly tighten the four Hex. Head Jam Nuts (Item 45) to 20 ft-lb [27 Nm] torque (See Figure 5).

MODULAR INPUT BRAKE (MIB)

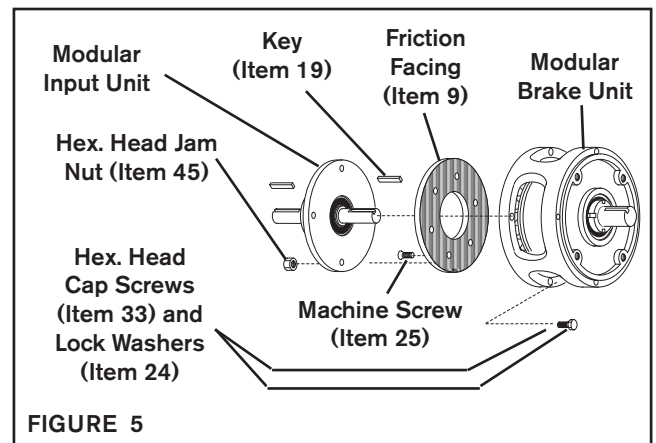

FIGURE 5

MOUNTING MODULAR BRAKE UNITS (MBU)

MODELS 625 AND 875 TO A MOTOR

- Remove the six Machine Screws (Item 25) that secure the Friction Facing (Item 9) to the MBU Disc Journal (Item 8) and save the Machine Screws and Friction Facing as spare parts (See Figure 5).
- Place the Key (Item 19) into the motor shaft; then, slide the motor shaft into the Modular Unit (See Figure 6).
- Rotate the Modular Unit until the clearance holes in the Modular Unit are aligned with the tapped holes in the Motor; then, using the four Hex. Head Cap Screws (Item 33) and Lock Washers (Item 24), secure the motor to the Modular Unit (See Figure 6).
- Alternately and evenly tighten the four Hex. Head Cap Screws to 20 ft-lb [27 Nm] torque.

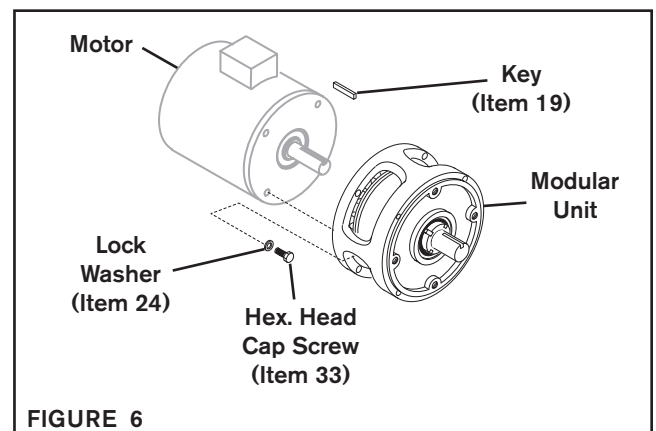
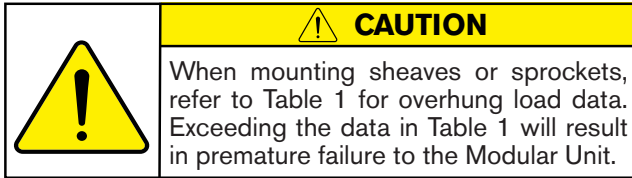

FIGURE 6

(continued...)

MOUNTING MODULAR BRAKE UNITS (MBU) (continued...)

ALL MODELS AND MOTOR TO A REDUCER



1. Place the Key (Item 19) into the output shaft of the Modular Unit and slide the output shaft of the Modular Unit and motor into the reducer.
2. Rotate Modular Unit and motor until holes in Modular Unit are aligned with holes in reducer flange, and air inlet ports of Modular Unit are facing down.
3. Using four Hex. Head Cap Screws, secure Modular Unit and motor to reducer.
4. Alternately and evenly tighten the four Hex. Head Cap Screws, making sure the Modular Unit and reducer faces are flush with each other.

HOUSING GUARD INSTALLATION

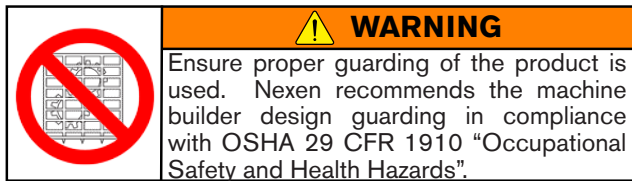

Each Modular Unit is provided with a Housing Guard. After combining the Modular Units, install the Housing Guard so one of the ribs of the Modular Unit housing is directly beneath the clamp on the Housing Guard. Tighten fastener to 35 in-lbs [4 Nm].

Waterproof guards are also available. Purchase waterproof guards from your local Nexen Distributor.

TABLE 1

OVERHUNG LOAD DATA			
MODEL	RPM	* Load 1" [25.4 mm] from Pilot Face	
		625	875
MBU	1200	321 lbs	321 lbs
	1800	281 lbs	281 lbs
MOU	1200	321 lbs	321 lbs
	1800	281 lbs	281 lbs
MIU	1200	279 lbs	279 lbs
	1800	244 lbs	244 lbs

* Based on 10,000 hrs. average life and using 50 psi air.

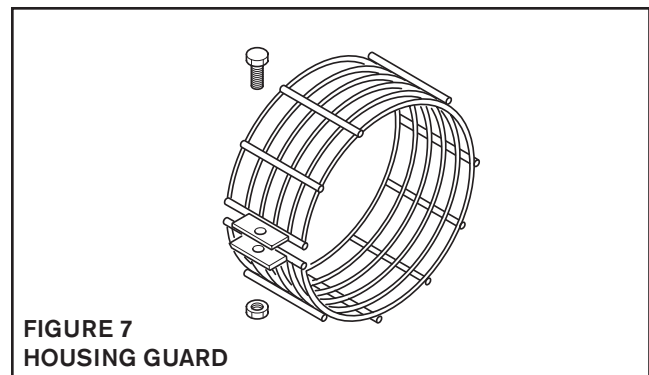

FIGURE 7
HOUSING GUARD

MOUNTING MODULAR UNITS ONTO MOUNTING FEET

U-SHAPED MOUNTING FOOT

Refer to Figure 8

1. Depending upon the desired air inlet orientation, remove two Hex. Head Jam Nuts, Bolts, and Lock Washers from the Modular Input Unit.
2. Set the Modular Unit onto the U-Shaped Mounting Foot.
3. Secure Modular Input Unit to U-Shaped Mounting Foot using the Hex. Head Bolts supplied with Mounting Foot.

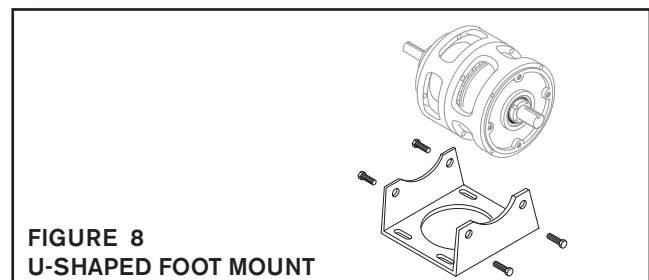

FIGURE 8
U-SHAPED FOOT MOUNT

L-SHAPED MOUNTING FOOT

Refer to Figure 9.

1. Set the Modular Unit onto the L-Shaped Mounting Foot.
2. Secure Modular Unit to Mounting Foot using Hex. Head Bolts supplied with L-Shaped Mounting Foot.

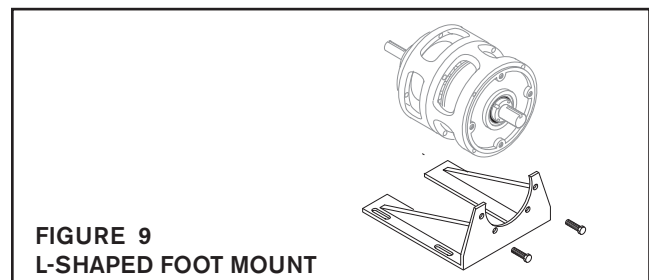

FIGURE 9
L-SHAPED FOOT MOUNT

LUBRICATION

NOTE

Nexen pneumatically actuated devices require clean, pressure regulated air for maximum performance and life. All seals in Nexen Pneumatically operated devices are lubricated for life and do not require additional lubrication.



However, some customers prefer to use an air line lubricator, which injects oil into the pressurized air, forcing an oil mist into the air chamber. This is acceptable, but care must be taken to ensure once an air mist lubrication system is used, it is continually used over the life of the product as the oil mist may wash free the factory installed lubrication.

Locate the lubricator above and within ten feet of the product, and use low viscosity oil such as SAE-10.

Synthetic lubricants are not recommended.

Nexen product's bearings are shielded and pre-lubricated, and require no further lubrication.

LUBRICATOR DRIP RATE SETTINGS

	 CAUTION
	These settings are for Nexen supplied lubricators. If you are not using a Nexen lubricator, calibration must follow the manufacturer's suggested procedure.

1. Close and disconnect the air line from the unit.
2. Turn the Lubricator Adjustment Knob counterclockwise three complete turns.
3. Open the air line.
4. Close the air line to the unit when a drop of oil forms in the Lubricator Sight Gage.
5. Connect the air line to the unit.
6. Turn the Lubricator Adjustment Knob clockwise until closed.
7. Turn the Lubricator Adjustment Knob counterclockwise one-third turn.
8. Open the air line to the unit.

AIR CONNECTIONS



All Nexen pneumatically actuated devices require clean and dry air, which meet or exceeds ISO 8573.1:2001 Class 4.4.3 quality.

NOTE

For quick response, Nexen recommends a quick exhaust valve and short air lines between the Control Valves and the Modular Units. Align the air inlet ports to a down position to allow condensation to drain out of the air chambers of the Modular Units.

Adjust the air pressure to approximately 50 psi [3.45 bar] when the Modular Unit is installed between a motor and gear reducer.

When the Modular Unit is mounted using sheaves or sprockets, the air pressure may be regulated between 10 psi [0.7 bar] to 80 psi [5.5 bar] to ensure air pressure is adequate for torque requirements.

	 CAUTION
	Low air pressure will cause slippage and overheating. Excessive air pressure will cause abrupt starts and stops, reducing Modular Unit life.

AIR CONNECTIONS (continued...)

The following are common air supply schemes used with this product. These are examples and not an all-inclusive list. All air circuits to be used with this product must be designed following EN983 guidelines.

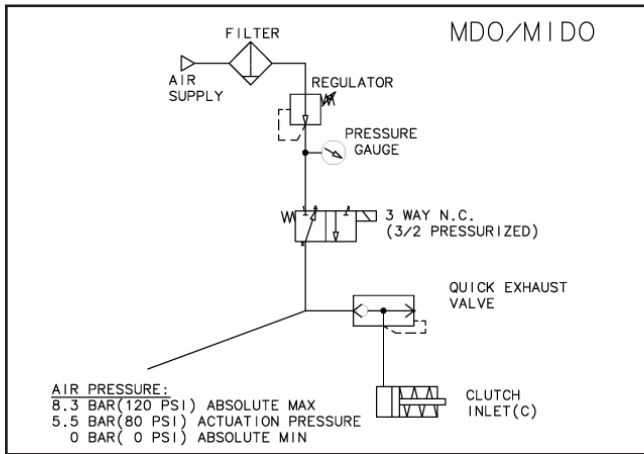

MDO: Modular Drive Unit (MDU) and Modular Output Unit (MOU)
MIDO: Modular Input Unit (MIU), Modular Drive Unit (MDU) & Modular Output Unit (MOU)

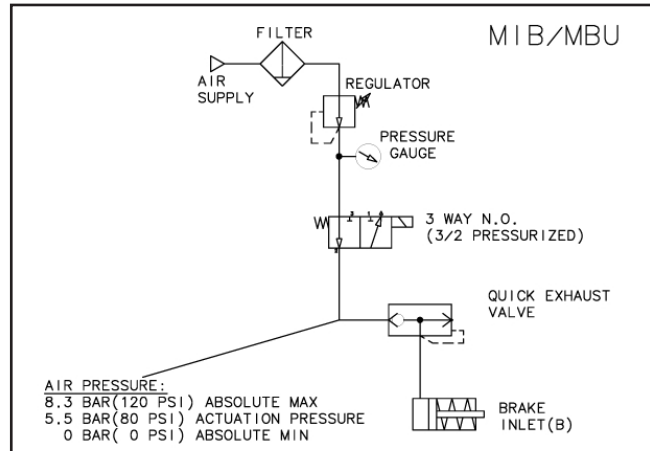

MIB: Modular Brake Unit (MBU) and Modular Input Unit (MIU)
MBU: Modular Brake Unit (MBU)

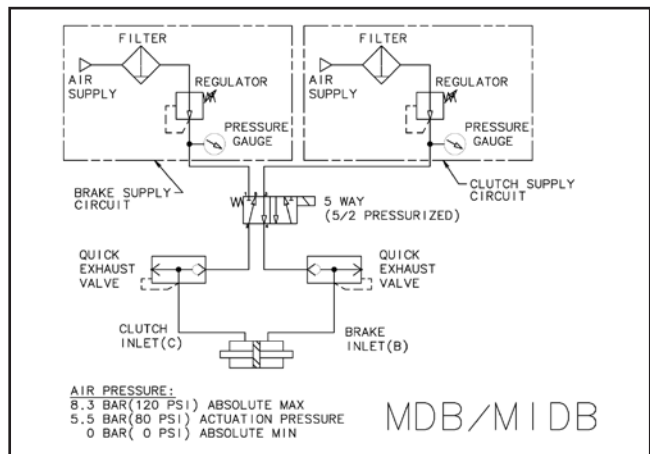

MDB: Modular Drive Unit (MDU) and Modular Brake Unit (MBU)
MIDB: Modular Input Unit (MIU), Modular Drive Unit (MDU), & Modular Brake Unit (MBU)

OPERATION

WARNING

Never exceed maximum operating speeds listed for your product. (See Table 2).

CAUTION

Never exceed life of facing material. Facing life depends on the volume of material and the total energy over the life of the unit. Expected life (in hrs) can be found by: $Time = Volume / (Power * Wear Rate)$.

CAUTION

The temperature limits for this product line are 4.5-104 Degree Celsius (40-220 Degree F).

TABLE 2

NEMA Motor/Frame Selection Chart			
Hp of Motor	Model	Frame #	Max RPM
0.5	625	56C	1800
0.5	875	143TC	900
0.75	625	56C	1800
0.75	875	143TC	1200
.75	875	145TC	900
1.0	625	56C	1800
1.0	875	143TC	1800
1.0	875	145TC	1200
1.5	875	145TC	1800
2.0	875	145TC	1800

TROUBLESHOOTING

MODEL	SYMPTOM	PROBABLE CAUSE	SOLUTION
MIU (Modular Input Unit)	Bearing noise.	Damaged Ball Bearings.	Replace the Ball Bearings.
MDU (Modular Drive Unit)	Failure to engage.	Leaking O-Ring Seals.	Replace the O-Ring Seals.
		Lack of lubrication on the Hub Spline.	Lubricate the Hub spline with Never-Seez®.
		Damaged Ball Bearings.	Replace the Ball Bearings.
	Failure to disengage.	Improper air pressure settings or faulty controls.	Adjust the air pressure setting or replace the controls.
		Lack of lubrication on the Hub spline.	Lubricate the Hub spline with Never-Seez®.
		Damaged Ball Bearings.	Replace the Ball Bearings.
MBU (Modular Brake Unit)	Failure to engage.	Broken or damaged Spring.	Replace the Spring.
		Leaking O-Ring Seals.	Replace the O-Ring Seals.
		Damaged Ball Bearings.	Replace the Ball Bearings.
	Failure to disengage.	Improper air pressure settings or faulty controls.	Adjust the air pressure setting or replace the controls.
		Worn or contaminated Friction Facings.	Replace the Friction Facings.
		Lack of lubrication on the Hub spline.	Lubricate the Hub spline with Never-Seez®.
MOU (Modular Output Unit)	Failure to engage.	Damaged Ball Bearings.	Replace the Ball Bearings.
		Broken or damaged Springs.	Replace the Springs.
		Worn or contaminated Friction Facings.	Replace the Friction Facings.

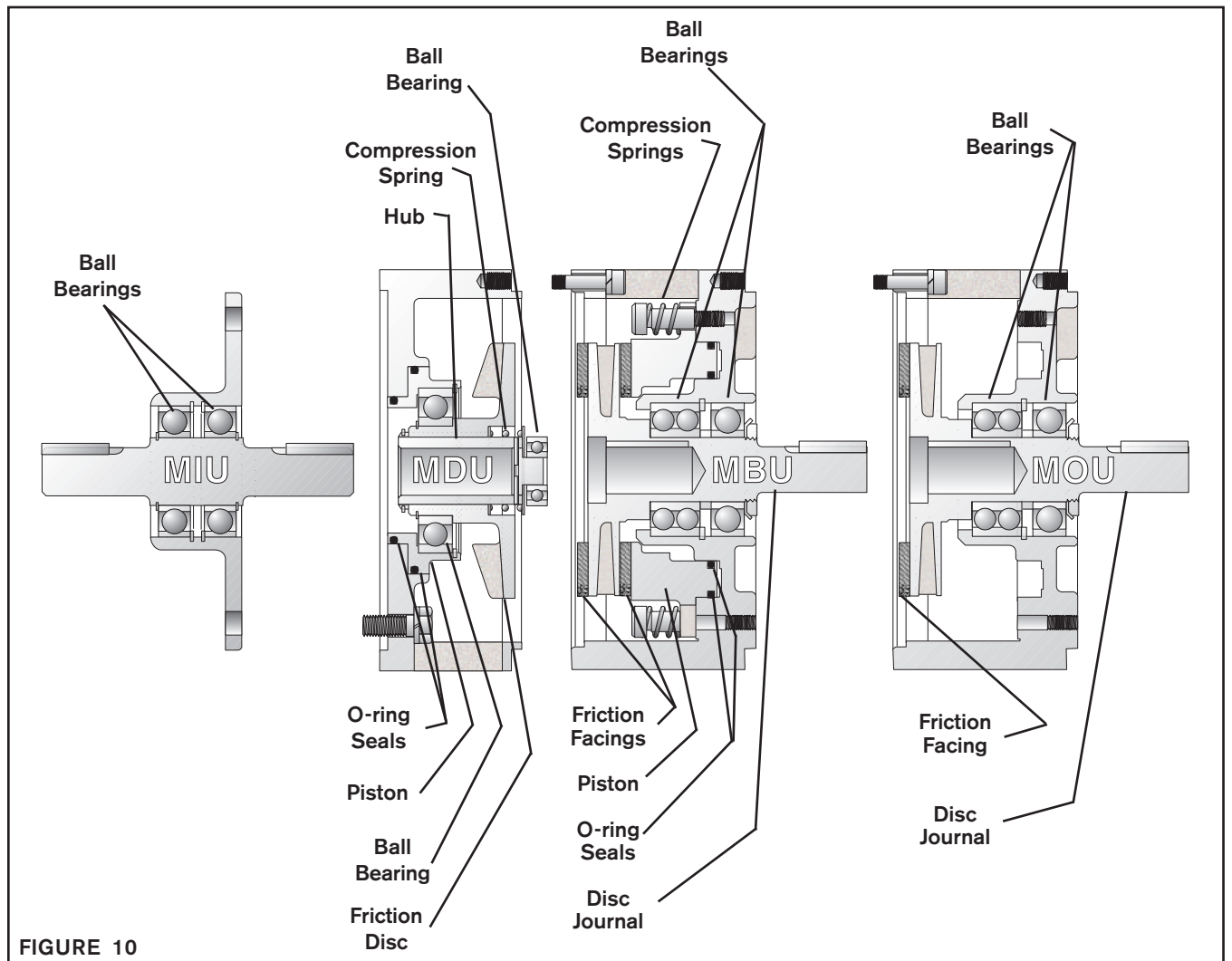

FIGURE 10

PARTS REPLACEMENT

NOTE

Modular Units must be unmounted and separated into individual components prior to maintenance or repair. Make sure you are in the correct section for the size and model of the Modular Unit you are repairing.

MODULAR INPUT UNIT (MIU)

Models 625 & 875

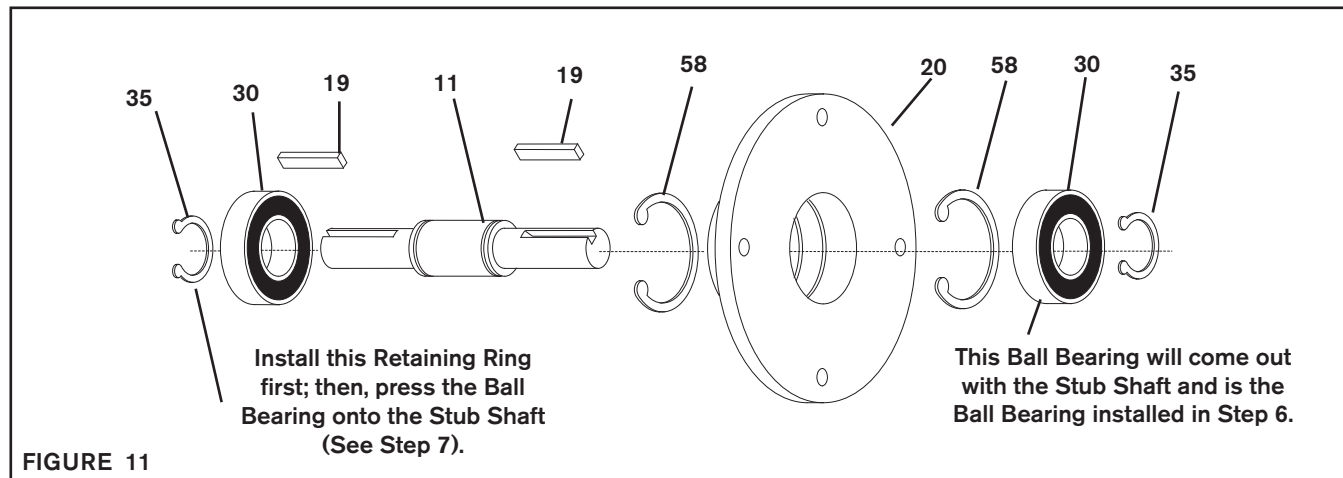

CAUTION

Special attention should be exercised when working with retaining rings. Always wear safety goggles when working with spring or tension loaded fasteners or devices.

1. Remove both Retaining Rings (Item 35) (See Figure 11).
2. With face of Bearing Flange (the side without ribs) (Item 20) facing down and fully supported, press Stub Shaft (Item 11) down and out of the Bearing Flange (See Figure 11).

NOTE

One Ball Bearing (Item 30) will come out with the Stub Shaft (Item 11).

3. Remove the first old Ball Bearing (Item 30) from Stub Shaft (Item 11) (See Figure 11).

NOTE

Do not remove the two Retaining Rings (Item 58) from the Bearing Flange (Item 20) (See Figure 13).

4. Press the second old Ball Bearing (Item 30) out of the Bearing Flange (Item 20) (See Figure 11).
5. Clean the bore of the Bearing Flange (Item 20) with fresh solvent, making sure all old Loctite® residue is removed (See Figure 11).

6. Apply an adequate amount of Loctite® 680 to evenly coat the outer race of the first new Ball Bearing (Item 30); then, press this Ball Bearing into the Bearing Flange (Item 20) until it is seated against the Retaining Ring (Item 58) (See Figure 11).
7. Reinstall the first Retaining Ring (Item 35) on Stub Shaft (Item 11) (See Figure 11).
8. Fully support the inner bearing race of the second new Ball Bearing (Item 30) and press it onto the Stub Shaft (Item 11) until it is seated against the Retaining Ring (Item 35) (See Figure 11).
9. Apply an adequate amount of Loctite 680 to evenly coat the outer race of the second new Ball Bearing (Item 30).
10. Supporting the inner race of the Ball Bearing located in the Bearing Flange (Item 20), press the second new Ball Bearing (Item 30) and Stub Shaft (Item 11) into the Bearing Flange and Ball Bearing until the second new Ball Bearing is seated against the Retaining Ring (Item 58) (See Figure 11).
11. Reinstall the second Retaining Ring (Item 35) (See Figure 11).

PARTS REPLACEMENT (continued...)

MODULAR DRIVE UNIT (MDU)

Models 625 and 875

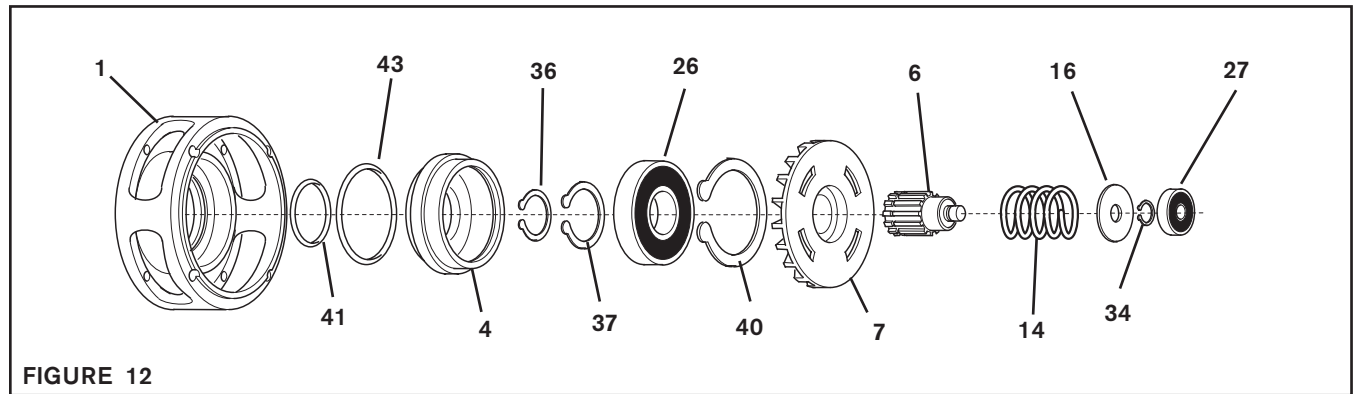

1. Remove the old Ball Bearing (Item 27) (See Figure 12).

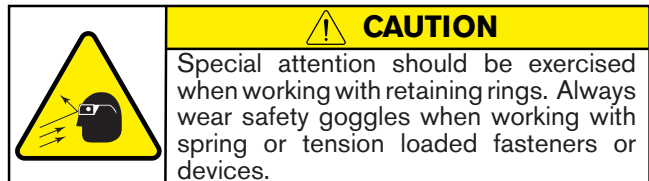

2. Remove the Retaining Ring (Item 36) from the Hub (Item 6) (See Figure 12).
3. Slide the Hub (Item 6), Compression Spring (Item 14), Spring Retainer Washer (Item 16) and Retaining Ring (Item 34) out of the Friction Disc (Item 7) (See Figure 12).
4. Press the Piston (Item 4), Friction Disc (Item 7), and Ball Bearing (Item 26) out of the Housing (Item 1) (See Figure 12).
5. Remove the old O-ring Seals (Items 41 and 43) from the Piston (Item 4) and Housing (Item 1) (See Figure 12).
6. Remove the Retaining Ring (Item 37) from the Friction Disc (Item 7); then, using a bearing puller, remove the Piston (Item 4) and old Ball Bearing (Item 26) from the Friction Disc (Item 7) (See Figure 12).
7. Remove the Retaining Ring (Item 40) from the Piston (Item 4) and press the old Ball Bearing (Item 26) out of the Piston (See Figure 12).
8. Clean the bearing bore of the Piston (Item 4) with fresh solvent, making sure all old Loctite® residue is removed (See Figure 12).
9. Apply an adequate amount of Loctite® 680 to evenly coat the outer race of the new Ball Bearing (Item 26) and press the new Ball Bearing into the Piston (Item 4) (See Figure 12).
10. Reinstall the Retaining Ring (Item 40) (See Figure 12).
11. Support the inner race of the new Ball Bearing (Item 26); then, press the Friction Disc (Item 7) into the Piston (Item 4) and new Ball Bearing (Item 26) (See Figure 12).
12. Reinstall the Retaining Ring (Item 37) (See Figure 12).
13. Lubricate the new O-ring Seals (Items 41 and 43) and the O-Ring contact surfaces of the Piston (Item 4) and Housing (Item 1) with a thin film of fresh O-Ring lubricant (See Figure 12).
14. Install the new O-Ring Seals (Items 41 and 43); then, slide the Piston (Item 4) and Friction Disc (Item 7) into the Housing (Item 1) (See Figure 12).
15. Inspect the Compression Spring (Item 14) for signs of fatigue and replace it if necessary (See Figure 12).
16. Apply a thin film of Never-Seez® to the splines of the Hub (Item 6); then, slide the Hub, Compression Spring (Item 14), Spring Retainer Washer (Item 16) and Retaining Ring (Item 34) into the Friction Disc (Item 7) (See Figure 12).
17. Reinstall the Retaining Ring (Item 36) (See Figure 12).
18. Slide a new Ball Bearing (Item 27) onto the Hub (Item 6) (See Figure 12).

PARTS REPLACEMENT (continued...)

MODULAR BRAKE UNIT (MBU)

Models 625 and 875

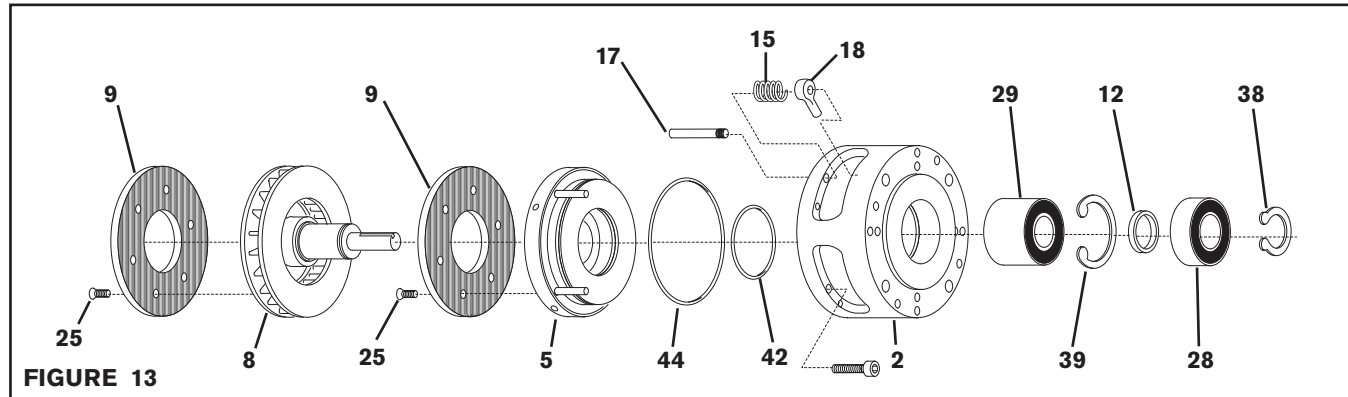

Refer to Figure 13.

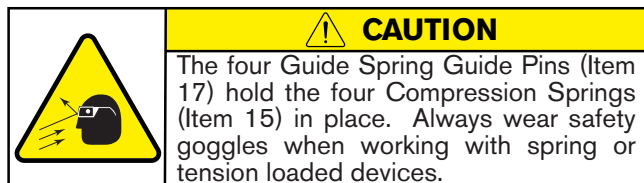

- Using a screw driver inserted through the holes in the back side of Housing (Item 2), remove the four Spring Guide Pins (Item 17); then, remove the Compression Springs (Item 15) and Eye Pins (Item 18) through the openings in the Housing (Item 2).

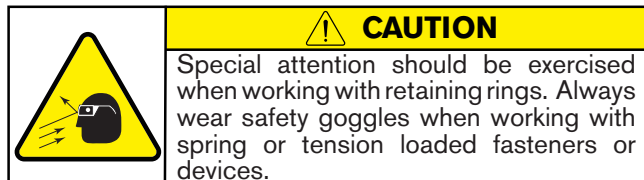

- Remove the Retaining Ring (Item 38).
- Fully support the Housing (Item 2) and press the Disc Journal (Item 8) out of the Housing.
- Using a bearing puller, remove the old Ball Bearing (Item 28) from the Housing (Item 2).
- Remove the Spacer (Item 12) and Retaining Ring (Item 39) from the Housing (Item 2).
- Press the old Ball Bearing (Item 29) out of the Housing (Item 2).
- Slide the Piston (Item 5) out of the Housing (Item 2).
- Remove old O-Ring Seals (Items 42 & 44) from Piston (Item 5).
- Remove the six old Flat Head Screws (Item 25) securing the old Friction Facing (Item 9) to the Piston (Item 5) and remove the old Friction Facing.
- Using six new Flat Head Screws (Item 25), secure a new Friction Facing (Item 9) to the Piston (Item 5).

- Tighten the six flat Head Screws to 22 in-lb [2.50 Nm] torque.
- Remove the six old Flat Head Screws (Item 25) securing the old Friction Facing (Item 9) to the Disc Journal (Item 8) and remove the old Friction Facing.
- Using six new Flat Head Screws (Item 25), secure a new Friction Facing (Item 9) to the Disc Journal (Item 8).
- Tighten the six flat Head Screws to 22 in-lb [2.50 Nm] torque.
- Clean the Bearing Bore of Housing (Item 2) with fresh solvent, making sure all old Loctite® residue is removed.
- Apply an adequate amount of Loctite® 680 to evenly coat the outer race of the new Ball Bearing (Item 29) and press the new Ball Bearing into the Housing (Item 2).
- Reinstall Spacer (Item 12) and Retaining Ring (Item 39).
- Apply an adequate amount of Loctite® 680 to evenly coat the outer race of the new Ball Bearing (Item 28) and press the new Ball Bearing into the Housing (Item 2).
- Lubricate the new O-Ring Seals (Items 42 and 44) and the O-Ring contact surfaces of the Housing (Item 2) and Piston (Item 5) with a thin film of fresh O-Ring lubricant.
- Reinstall the new O-Ring Seals (Items 42 and 44) onto the Piston (Item 5); then, align the pins on the Piston with the holes in the Housing (Item 2) and slide the Piston into the Housing.
- Support the inner race of the new Ball Bearing (Item 28) and press the Disc Journal (Item 8) into the Ball Bearings (Items 28 and 29) and Housing (Item 2).
- Reinstall the Retaining Ring (Item 38).
- Install a Compression Spring (Item 15) on each Spring Guide Pin; then, compress the Compression Springs and insert the four Eye Pins (Item 18) into the four holes in the Piston (Item 5), aligning the Compression Springs with the holes in the Housing (Item 2).
- Slide the Spring Guide Pins (Item 17) through the Compression Springs (Item 15) and the holes in the Eye Pins (Item 18), screwing each Spring Guide Pin into the Housing.

PARTS REPLACEMENT (continued...)

MODULAR OUTPUT UNIT (MOU)

Models 625 and 875

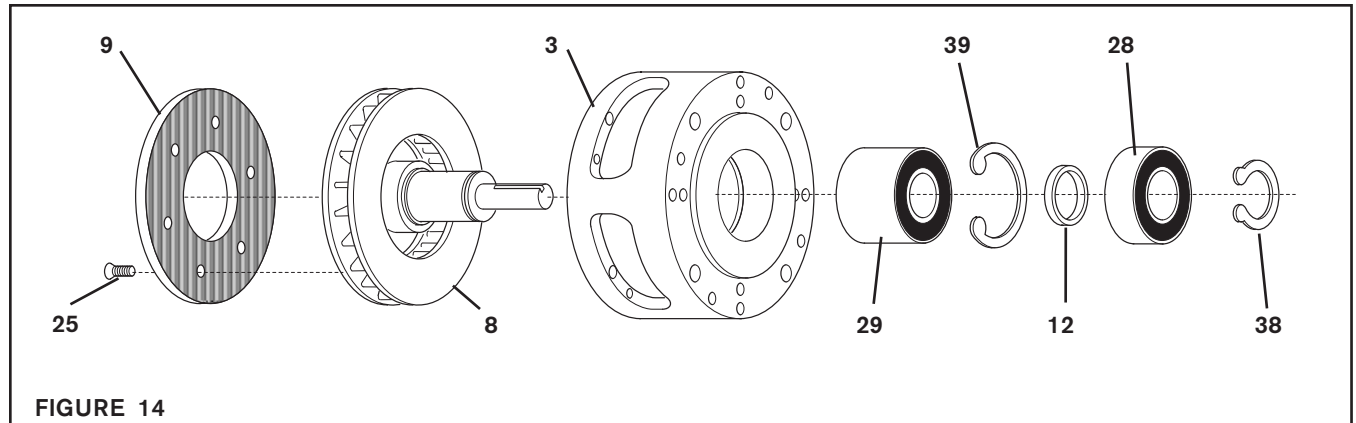

Refer to Figure 14.

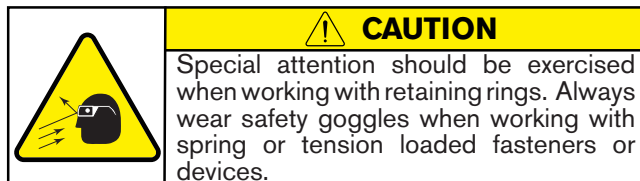

1. Remove the Retaining Ring (Item 38).
2. Fully supporting the Housing (Item 3), press the Disc Journal (Item 8) out of the Housing.
3. Using a bearing puller, remove the old Ball Bearing (Item 28) from the Housing (Item 3).
4. Remove the Spacer (Item 12) and Retaining Ring (Item 39) from the Housing (Item 3).
5. Press the old Ball Bearing (Item 29) out of the Housing (Item 3).
6. Remove the six old Flat Head Screws (Item 25) securing the old Friction Facing (Item 9) to the Disc Journal (Item 8) and remove the old Friction Facing.
7. Using six new Flat Head Screws (Item 25), secure a new Friction Facing (Item 9) to the Disc Journal (Item 8).
8. Tighten the six Flat Head Screws to 22 in-lb [2.50 Nm] torque.
9. Clean the Bearing Bore of the Housing (Item 3) with fresh solvent, making sure all old Loctite® residue is removed.
10. Apply an adequate amount of Loctite® 680 to evenly coat the outer race of the new Ball Bearing (Item 29) and press the new Ball Bearing into the Housing (Item 3).
11. Reinstall the Spacer (Item 12) and the Retaining Ring (Item 39).
12. Apply an adequate amount of Loctite® 680 to evenly coat the outer race of the new Ball Bearing (Item 28) and press the new Ball Bearing into the Housing (Item 3).
13. Support the inner race of the new Ball Bearing (Item 28) and press the Disc Journal (Item 8) into the Ball Bearings (Items 28 and 29) and Housing (Item 3).
14. Reinstall the Retaining Ring (Item 38).

REPLACEMENT PARTS

The item or balloon number for all Nexen products is used for part identification on all product parts lists, product price lists, unit assembly drawings, bills of materials, and instruction manuals.

When ordering replacement parts, specify model designation, item number, part description, and quantity. Purchase replacement parts through your local Nexen Distributor.

NOTE

Make sure you are in the correct section for the size and model of your Modular Unit.

MODULAR INPUT UNIT (MIU)

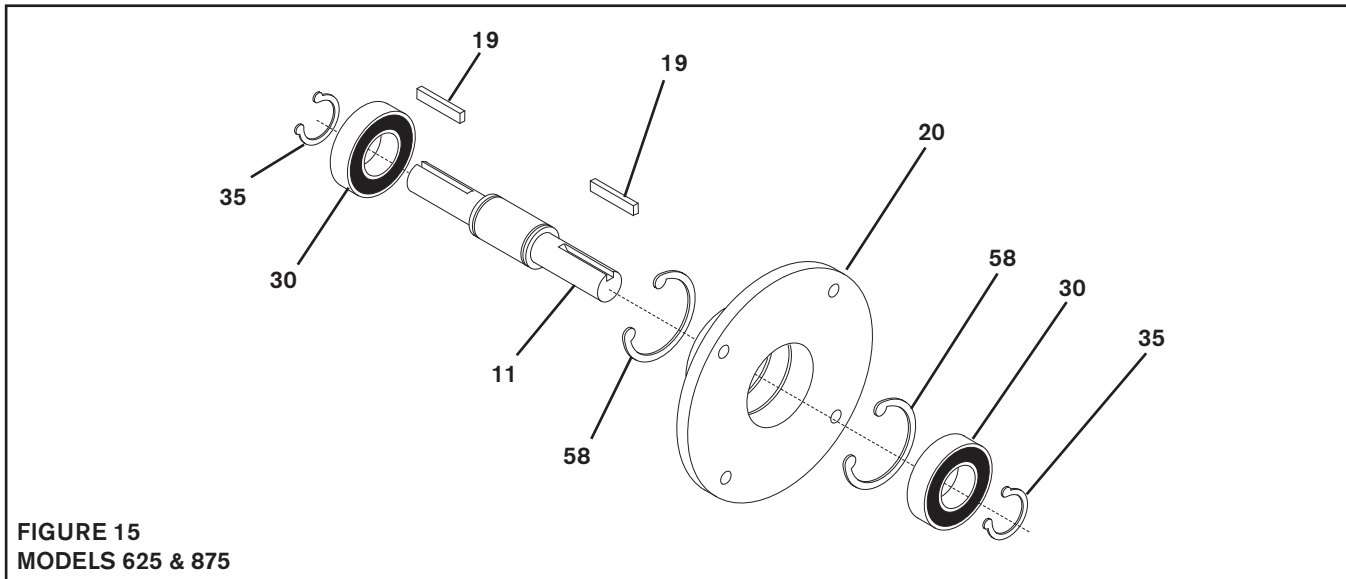

FIGURE 15
MODELS 625 & 875

ITEM	DESCRIPTION	QTY
11	Stub Shaft	1
19	Key	2
20	Bearing Flange	1
30 ¹	Ball Bearing	2

ITEM	DESCRIPTION	QTY
35	Retaining Ring (Ext.)	2
45	Hex. Head Jam Nut (Not Shown)	4
58	Retaining Ring (Int.)	2

¹ Denotes Repair Kit item.

MIU 625 and 875 Repair Kit No. 930000.

REPLACEMENT PARTS (continued...)

MODULAR DRIVE UNIT (MDU)

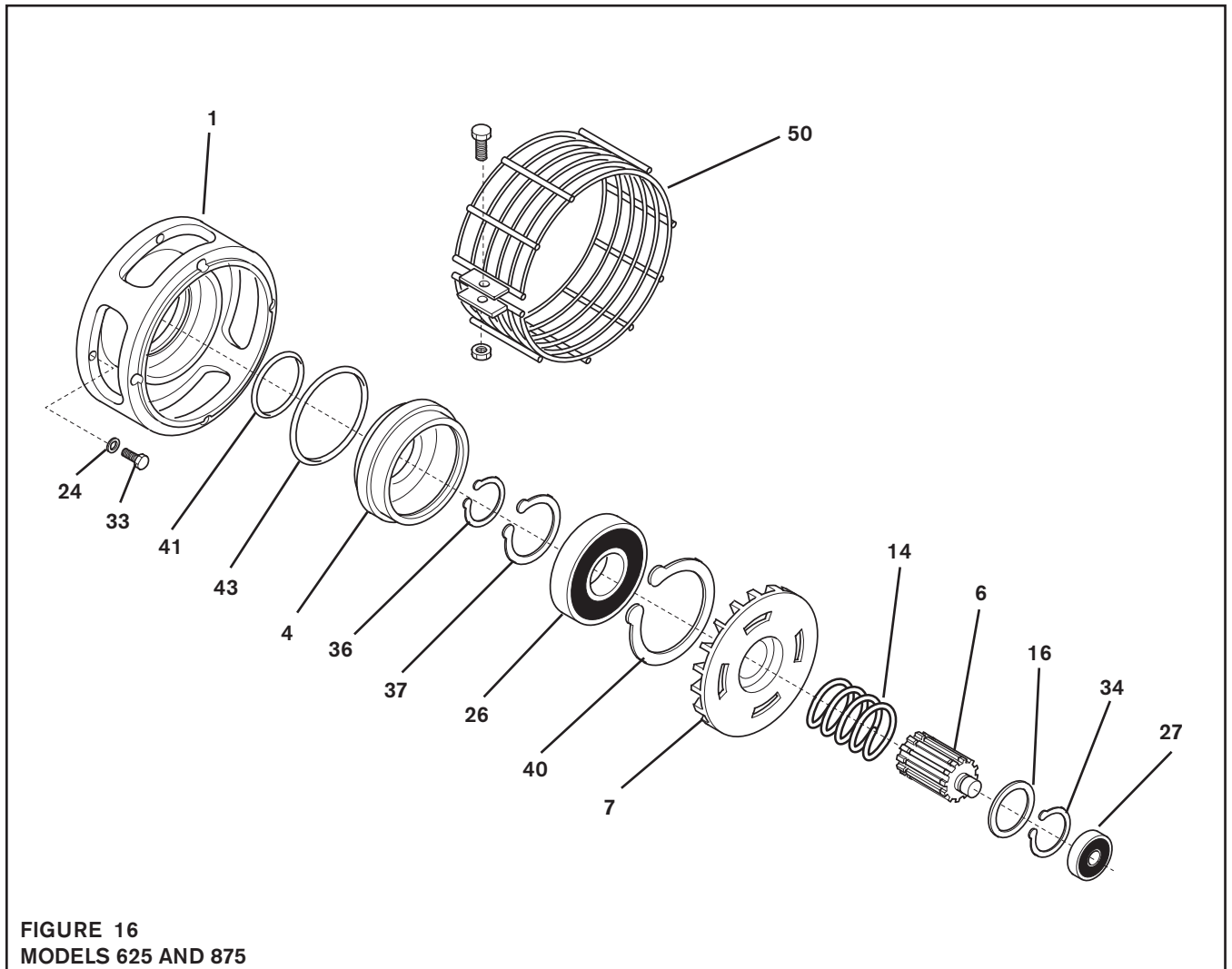

FIGURE 16
MODELS 625 AND 875

ITEM	DESCRIPTION	QTY
1	Housing	1
4	Piston	1
6	Hub	1
7	Friction Disc	1
14 ¹	Compression Spring	1
16	Spring Retainer Washer	1
19	Key (Not Shown)	1
24	Lock Washer	4
26 ¹	Ball Bearing	1

ITEM	DESCRIPTION	QTY
27 ¹	Ball Bearing	1
33	Hex. Head Cap Screw	4
34	Retaining Ring (Ext.)	1
36	Retaining Ring (Ext.)	1
37	Retaining Ring (Ext.)	1
40	Retaining Ring (Int.)	1
41 ¹	O-Ring Seal	1
43 ¹	O-Ring Seal	1
50	Housing Guard	1

¹ Denotes Repair Kit item.

MDU 625 and 875 Repair Kit No. 930100.

REPLACEMENT PARTS (continued...)

MODULAR BRAKE UNIT (MBU)

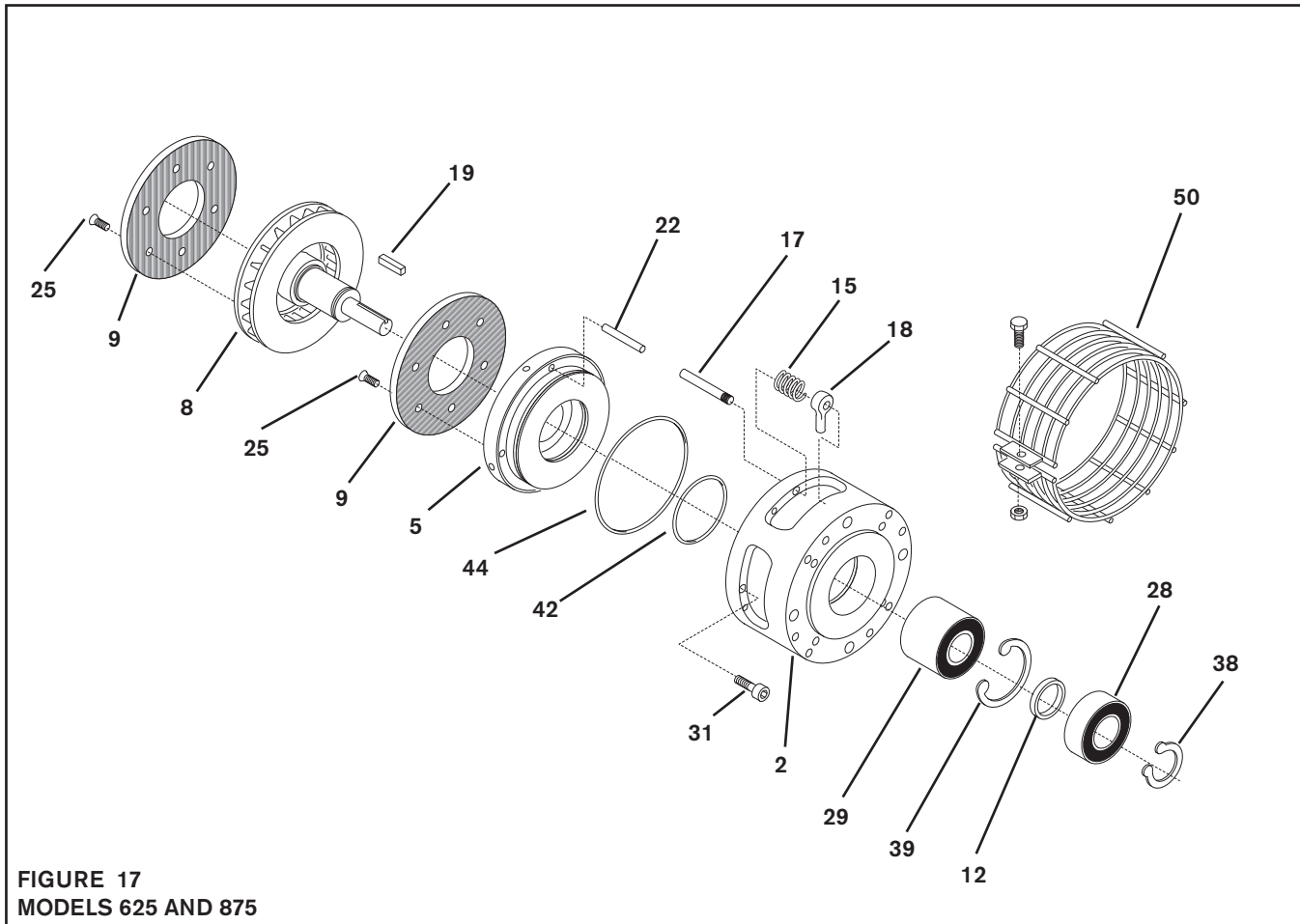

FIGURE 17
MODELS 625 AND 875

ITEM	DESCRIPTION	QTY
2	Housing	1
5	Piston	1
8	Disc Journal	1
9 ^{1,2}	Friction Facing	2
12	Spacer	1
15 ¹	Compression Spring	4
17	Spring Guide Pin	4
18	Eye Pin	4
19	Key	1
22	Spring Pin	4

ITEM	DESCRIPTION	QTY
25 ^{1,2}	Flat Head Screw	12
28 ¹	Ball Bearing	1
29 ¹	Ball Bearing	1
31	Socket Head Cap Screw	4
38	Retaining Ring (Ext.)	1
39	Retaining Ring (Int.)	1
42 ¹	O-Ring Seal	1
44 ¹	O-Ring Seal	1
50	Housing Guard	1

¹ Denotes Repair Kit item.
MBU 625 and 875 Repair Kit No. 930200.

² Denotes Friction Facing Kit item.
MBU 625 and 875 Friction Facing Kit No. 930276.

REPLACEMENT PARTS (continued...)

MODULAR OUTPUT UNIT (MOU)

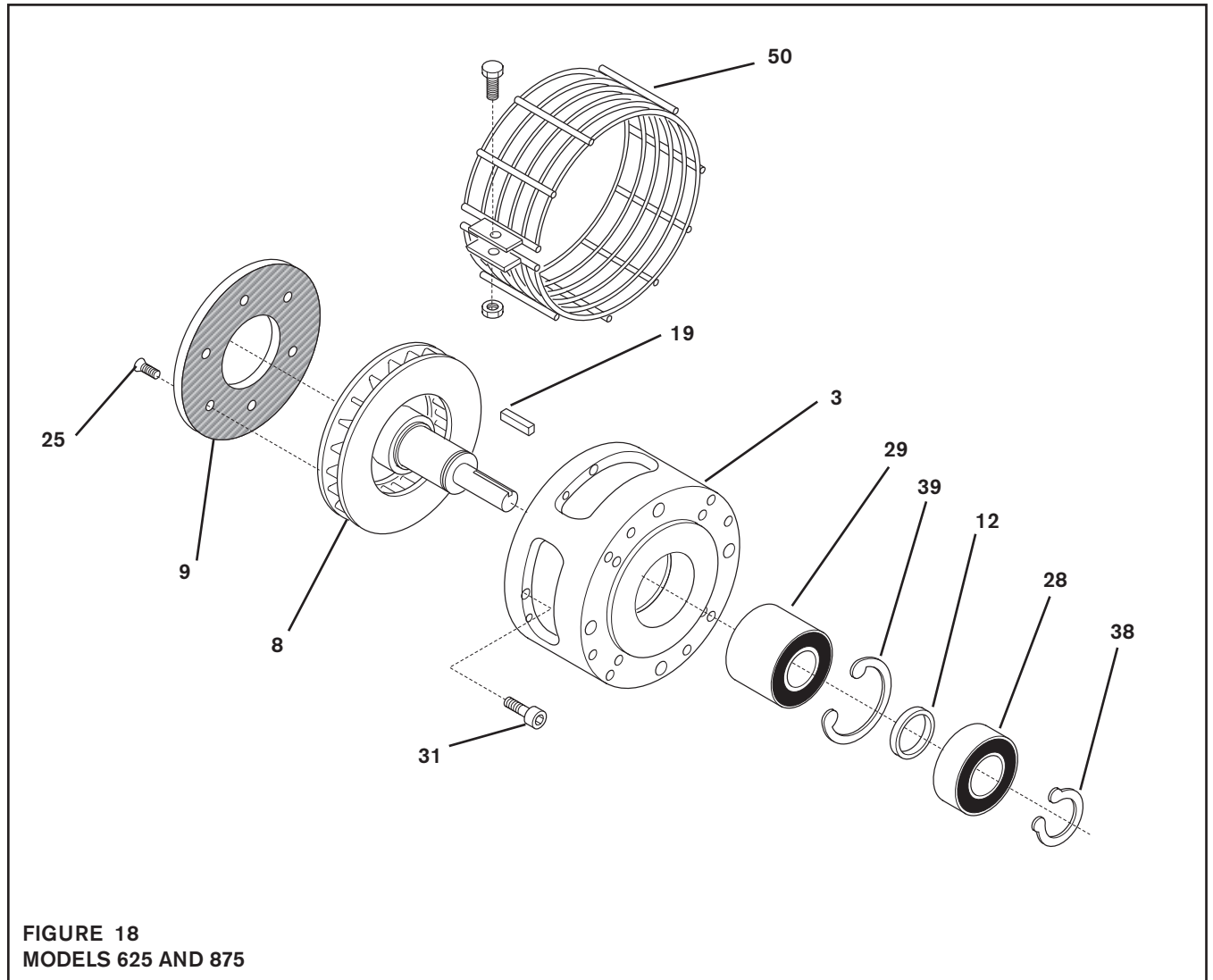

ITEM	DESCRIPTION	QTY
3	Housing	1
8	Disc Journal	1
9 ^{1,2}	Friction Facing	1
12 ¹	Spacer	1
19	Key	1
25 ^{1,2}	Flat Head Machine Screw	6

ITEM	DESCRIPTION	QTY
28 ¹	Ball Bearing	1
29 ¹	Ball Bearing	1
31	Socket Head Cap Screw	4
38	Retaining Ring	1
39	Retaining Ring	1
50	Housing Guard	1

¹ Denotes Repair Kit item.
MOU 625 and 875 Repair Kit No. 930300.

² Denotes Friction Facing Kit item.
MBU 625 and 875 Friction Facing Kit No. 930276.

ACCESSORIES

MODULAR HOUSING GUARDS		
TYPE	MODELS	PRODUCT NUMBER
Ring Guard	All 625 and 875	929500
Waterproof Guard (Not Shown)	MBU 625 and 875	929502
	MDU 625 and 875	929501

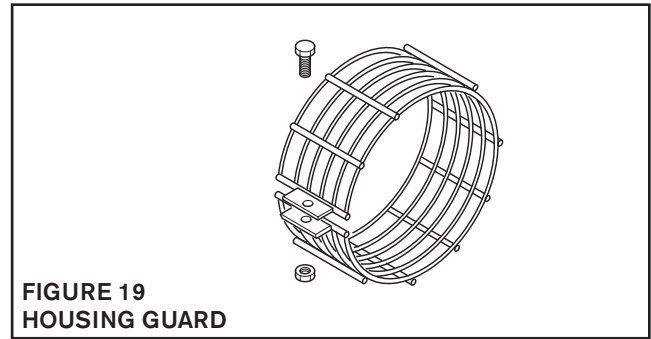

MODULAR FOOT MOUNTS		
TYPE	MODELS	PRODUCT NUMBER
U-Shaped Foot Mount	All 625 and 875	929300
L-Shaped Foot Mount	MBU 625 and 875	931000

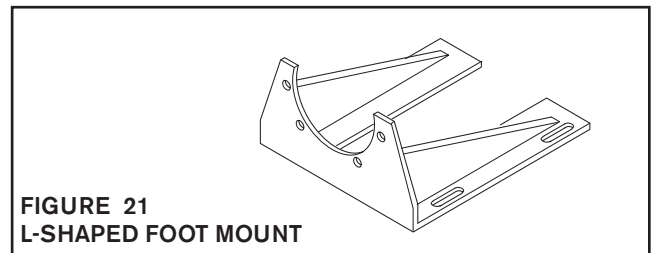
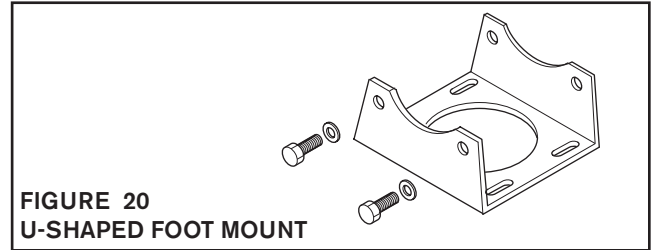

WARRANTY

Warranties

Nexen warrants that the Products will (a) be free from any defects in material or workmanship for a period of 12 months from the date of shipment, and (b) will meet and perform in accordance with the specifications in any engineering drawing specifically for the Product that is in Nexen's current product catalogue, or that is accessible at the Nexen website, or that is attached to this Quotation and that specifically refers to this Quotation by its number, subject in all cases to any limitations and exclusions set out in the drawing. NEXEN MAKES NO OTHER WARRANTY, EXPRESS OR IMPLIED, AND ALL IMPLIED WARRANTIES, INCLUDING WITHOUT LIMITATION, IMPLIED WARRANTIES OF MERCHANTABILITY AND FITNESS FOR A PARTICULAR PURPOSE ARE HEREBY DISCLAIMED. This warranty applies only if: (a) the Product has been installed, used and maintained in accordance with any applicable Nexen installation or maintenance manual for the Product; (b) the alleged defect is not attributable to normal wear and tear; (c) the Product has not been altered, misused or used for purposes other than those for which it was intended; and (d) Buyer has given written notice of the alleged defect to Nexen, and delivered the allegedly defective Product to Nexen, within one year of the date of shipment.

Exclusive Remedy

The exclusive remedy for the Buyer for any breach of any warranties provided in connection with this agreement will be, at the election of Nexen: (a) repair or replacement with new, serviceably used, or reconditioned parts or products; or (b) issuance of credit in the amount of the purchase price paid to Nexen by the Buyer for the Products.

Agent's Authority

Buyer agrees that no agent, employee or representative of Nexen has authority to bind Nexen to any affirmation, representation, or warranty concerning the Products other than those warranties expressly set forth herein.

Limitation on Nexen's Liability

TO THE EXTENT PERMITTED BY LAW NEXEN SHALL HAVE NO LIABILITY TO BUYER OR ANY OTHER PERSON FOR INCIDENTAL DAMAGES, SPECIAL DAMAGES, CONSEQUENTIAL DAMAGES OR OTHER DAMAGES OF ANY KIND OR NATURE WHATSOEVER, WHETHER ARISING OUT OF BREACH OF WARRANTY OR OTHER BREACH OF CONTRACT, NEGLIGENCE OR OTHER TORT, OR OTHERWISE, EVEN IF NEXEN SHALL HAVE BEEN ADVISED OF THE POSSIBILITY OR LIKELIHOOD OF SUCH POTENTIAL LOSS OR DAMAGE. For all of the purposes hereof, the term "consequential damages" shall include lost profits, penalties, delay damages, liquidated damages or other damages and liabilities which Buyer shall be obligated to pay or which Buyer may incur based upon, related to or arising out of its contracts with its customers or other third parties. In no event shall Nexen be liable for any amount of damages in excess of amounts paid by Buyer for Products or services as to which a breach of contract has been determined to exist. The parties expressly agree that the price for the Products and the services was determined in consideration of the limitation on damages set forth herein and such limitation has been specifically bargained for and constitutes an agreed allocation of risk which shall survive the determination of any court of competent jurisdiction that any remedy herein fails of its essential purpose.

Inspection

Buyer shall inspect all shipments of Products upon arrival and shall notify Nexen in writing, of any shortages or other failures to conform to these terms and conditions which are reasonably discoverable upon arrival without opening any carton or box in which the Products are contained. Such notice shall be sent within 14 days following arrival. All notifications shall be accompanied by packing slips, inspection reports and other documents necessary to support Buyer's claims. In addition to the foregoing obligations, in the event that Buyer receives Products that Buyer did not order, Buyer shall return the erroneously shipped Products to Nexen within thirty (30) days of the date of the invoice for such Products; Nexen will pay reasonable freight charges for the timely return of the erroneously shipped Products, and issue a credit to Buyer for the returned Products at the price Buyer paid for them, including any shipping expenses that Nexen charged Buyer. All shortages, overages and nonconformities not reported to Nexen as required by this section will be deemed waived.

Limitation on Actions

No action, regardless of form, arising out of any transaction to which these terms and conditions are applicable may be brought by the Buyer more than one year after the cause of action has accrued.

nexen[®]

Nexen Group, Inc.
560 Oak Grove Parkway
Vadnais Heights, MN 55127

800.843.7445
Fax: 651.286.1099
www.nexengroup.com

ISO 9001 Certified