

Power Off Activated Type Electromagnetic Brake Motors

6 W (1/125 HP)

Frame Size: □60 mm (□2.36 in.)



(Gearhead sold separately)

Specifications

● Motor (RoHS)



Model		Rating	Output Power W HP	Voltage VAC	Frequency Hz	Current A	Starting Torque mN·m oz-in	Rated Torque mN·m oz-in	Rated Speed r/min	Capacitor μF
Pinion Shaft Type	Round Shaft Type									
Ⓟ 2RK6GN-AW2MU	2RK6A-AW2MU	30 minutes	6 1/125	Single-Phase 110	60	0.235	45	41	1450	3.5
				Single-Phase 115		0.242				
Ⓟ 2RK6GN-CW2ME	2RK6A-CW2ME	30 minutes	6 1/125	Single-Phase 220	50	0.107	50	49	1150	0.8
					60	0.109	6.3	5.8	1450	
				Single-Phase 230	50	0.112	50	49	1200	
					60	0.113	6.3	5.8	1450	
Ⓟ 2IK6GN-SW2M	2IK6A-SW2M	Continuous	6 1/125	Three-Phase 200	50	0.081	49	49	1200	-
					60	0.072	5.8	5.8	1400	
				Three-Phase 220	60	0.076	41	41	1500	
						0.079	5.8	5.8		

- This type of motor does not contain a built-in friction brake mechanism similar to the reversible motors.
- The **U** and **E** at the end of the model name indicate that the unit includes a capacitor. These letters are not listed on the motor nameplate. When the motor is approved under various safety standards, the model name on the nameplate is the approved model name. → Page H-11
- Details of safety standards → Page H-2
- Ⓟ: Impedance protected.

Electromagnetic Brake (Power Off Activated Type)

Motor Model	Voltage	Frequency Hz	Current A	Input W	Holding Brake Torque mN·m oz-in
	VAC				
2RK6GN-AW2MU 2RK6A-AW2MU	Single-Phase 110	60	0.03	3	30
	Single-Phase 115				4.2
2RK6GN-CW2ME 2RK6A-CW2ME	Single-Phase 220	50	0.02	3	30 4.2
		60			
	Single-Phase 230	50			
		60			
2IK6GN-SW2M 2IK6A-SW2M	Single-Phase 200	50	0.02	3	30 4.2
	Single-Phase 220	60			
		Single-Phase 230			

Product Line

● Motor (RoHS)

Model	
Pinion Shaft Type	Round Shaft Type
2RK6GN-AW2MU	2RK6A-AW2MU
2RK6GN-CW2ME	2RK6A-CW2ME
2IK6GN-SW2M	2IK6A-SW2M

—The following items are included in each product.—
 Motor, Capacitor*, Capacitor Cap*, Operating Manual
 *Only for single-phase motors

High Strength, Long Life, Low Noise V Series

Highest Maximum Permissible torque, 10,000 hours of life and quiet operation. For more details on **V** Series see page C-149 or visit www.orientalmotor.com.



● Parallel Shaft Gearhead (Sold separately) **(RoHS)**

Gearhead Type		Gearhead Model	Gear Ratio
Parallel Shaft	Long Life, Low Noise GN-S Gearhead	2GN□SA	3, 3.6, 5, 6, 7.5, 9, 12.5, 15, 18, 25, 30, 36, 50, 60, 75, 90, 100, 120, 150, 180
		2GN10XS (Decimal Gearhead)	

The following items are included in each product.
Gearhead, Mounting Screws, Operating Manual

● The following gearheads are also available. For details, please refer to website (www.orientalmotor.com) or contact the nearest Oriental Motor sales office.

Gearhead Type		Gearhead Model	Gear Ratio
Parallel Shaft	(RoHS) GN-K Gearhead	2GN□KA	3~180
		2GN10XK (Decimal Gearhead)	

■ Gearmotor – Torque Table

- Enter the gear ratio in the box (□) within the gearhead model name.
- A colored background (□) indicates gear shaft rotation in the same direction as the motor shaft, while the others rotate in the opposite direction.
- The speed is calculated by dividing the motor's synchronous speed (50 Hz: 1500 r/min, 60 Hz: 1800 r/min) by the gear ratio. The actual speed is 2~20% less than the displayed value, depending on the load.
- To reduce the speed beyond the gear ratio in the table, attach a decimal gearhead (gear ratio 10:1) between the gearhead and the motor. In that case, the permissible torque is 3 N·m (26 lb-in).

◇ 50 Hz

Unit = Upper values: N·m/Lower values: lb-in

Model Motor/ Gearhead	Speed r/min	500	417	300	250	200	167	120	100	83	60	50	42	30	25	20	17	15	12.5	10	8.3
	Gear Ratio	3	3.6	5	6	7.5	9	12.5	15	18	25	30	36	50	60	75	90	100	120	150	180
2RK6GN-CW2ME 2IK6GN-SW2M	2GN□SA	0.12 1.06	0.14 1.23	0.20 1.77	0.24 2.1	0.30 2.6	0.36 3.1	0.50 4.4	0.60 5.3	0.71 6.2	0.89 7.8	1.1 9.7	1.3 11.5	1.6 14.1	1.9 16.8	2.4 21	2.9 25	3 26	3 26	3 26	3 26

◇ 60 Hz

Unit = Upper values: N·m/Lower values: lb-in

Model Motor/ Gearhead	Speed r/min	600	500	360	300	240	200	144	120	100	72	60	50	36	30	24	20	18	15	12	10
	Gear Ratio	3	3.6	5	6	7.5	9	12.5	15	18	25	30	36	50	60	75	90	100	120	150	180
2RK6GN-AW2MU 2RK6GN-CW2ME 2IK6GN-SW2M	2GN□SA	0.10 0.88	0.12 1.06	0.17 1.50	0.20 1.77	0.25 2.2	0.30 2.6	0.42 3.7	0.50 4.4	0.60 5.3	0.75 6.6	0.90 7.9	1.1 9.7	1.4 12.3	1.6 14.1	2.0 17.7	2.4 21	2.7 23	3 26	3 26	3 26

■ Permissible Overhung Load and Permissible Thrust Load

Motor (Round shaft type) → Page C-17

Gearhead → Page C-17

■ Permissible Load Inertia J of Gearhead

→ Page C-18

● Enter the gear ratio in the box (□) within the model name.

Starting and Braking Characteristics (Reference Values)

Single-Phase Motor

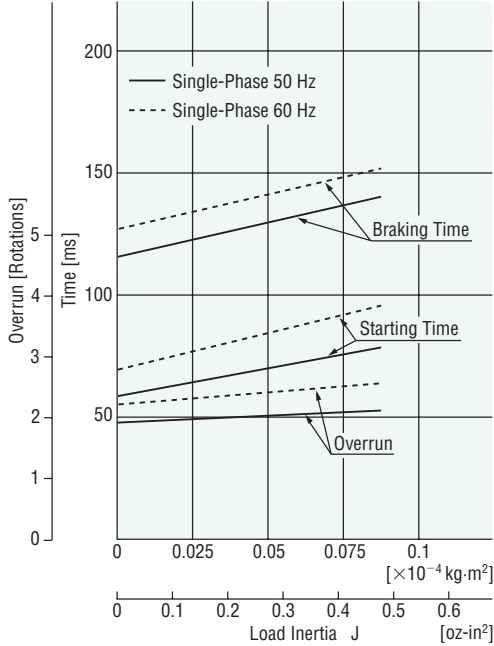

Three-Phase Motor

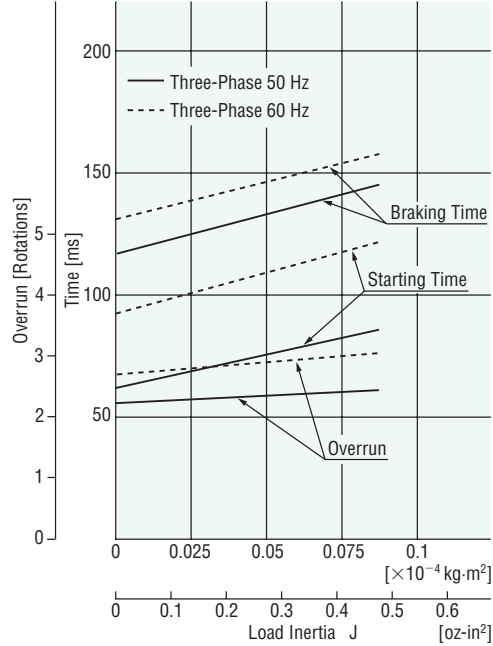

Dimensions Unit = mm (in.)

● Mounting screws are included with gearheads. Dimensions for mounting screws → Page C-280

Motor/Gearhead

Mass: Motor 0.9 kg (1.98 lb.)
Gearhead 0.4 kg (0.88 lb.)

Motor Model	Gearhead Model	Gear Ratio	L	DXF
2RK6GN-AW2MU 2RK6GN-CW2ME 2IK6GN-SW2M	2GN□SA	3~18	30 (1.18)	A462AU
25~180		40 (1.57)	A462BU	

● Enter the gear ratio in the box (□) within the model name.

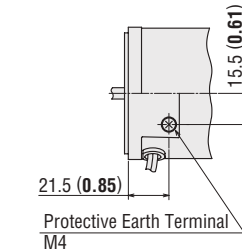
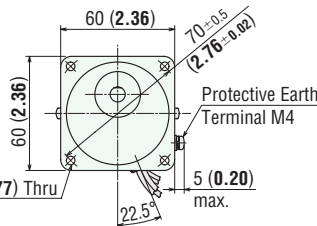
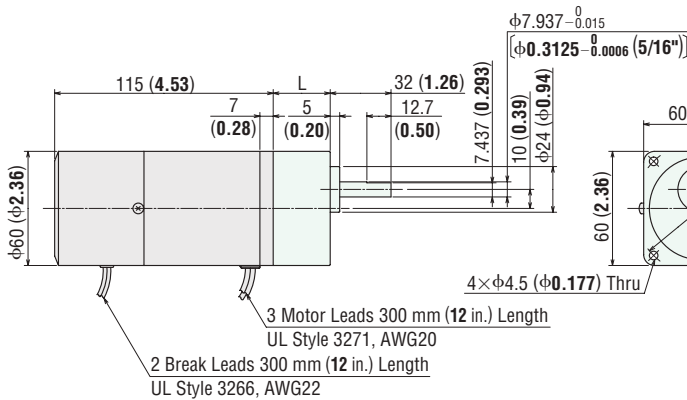

Detail Drawing of Protective Earth Terminal

Shaft Section of Round Shaft Type

The motor's dimensions (excluding the shaft section) are the same as those of the pinion shaft types.

Mass: 0.9 kg (1.98 lb.)

DXF A463

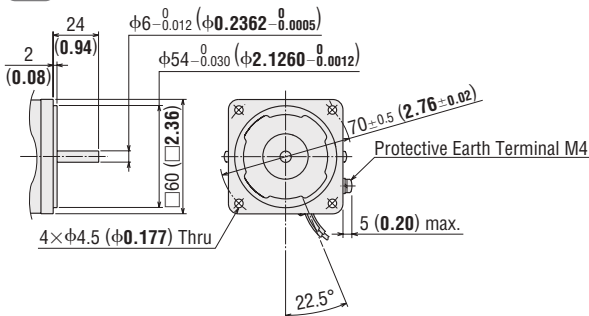

Decimal Gearhead

Can be connected to **GN** pinion shaft type.

2GN10XS

Mass: 0.2 kg (0.44 lb.)

DXF A003

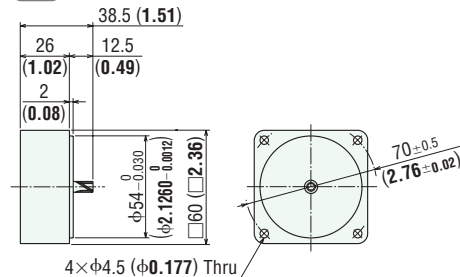

◇ Capacitor
(Included with single-phase motors)

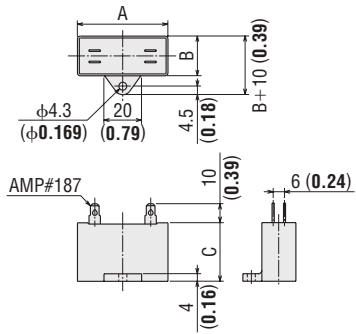

◇ Capacitor Dimensions Unit = mm (in.)

Model		Capacitor Model	A	B	C	Mass g (oz.)	Capacitor Cap
Pinion Shaft Type	Round Shaft Type						
2RK6GN-AW2MU	2RK6A-AW2MU	CH35FAUL2	31 (1.22)	17 (0.67)	27 (1.06)	22 (0.78)	Included
2RK6GN-CW2ME	2RK6A-CW2ME	CH08BFAUL	31 (1.22)	17 (0.67)	27 (1.06)	23 (0.81)	

Connection Diagrams

→ Page C-114

Linear Head, Accessories and Peripheral Equipment

Linear Motion
Linear Heads
→ Page C-247



Instantaneous Stop
Brake Pack
→ Page C-253



Accessories
→ Page C-263



- Introduction
- Induction Motors
- Reversible Motors
- Electromagnetic Brake Motors
- V Series
- Clutch & Brake Motors
- Synchronous Motors
- Low-Speed Synchronous Motors
- Waterright Dust-Resistant Motors
- Torque Motors
- Right-Angle Gearheads
- Linear Heads
- Brake Pack
- Accessories
- Installation

Power Off Activated Type Electromagnetic Brake Motors

15 W (1/50 HP)

Frame Size: □70 mm (□2.76 in.)



(Gearhead sold separately)

Specifications

● Motor (RoHS)



Model		Rating	Output Power W HP	Voltage VAC	Frequency Hz	Current A	Starting Torque mN·m oz·in	Rated Torque mN·m oz·in	Rated Speed r/min	Capacitor μF
Pinion Shaft Type	Round Shaft Type									
TP	3RK15GN-AW2MU	30 minutes	15 1/50	Single-Phase 110	60	0.42	100	105	1450	6.0
				Single-Phase 115		0.41		14.2		
TP	3RK15GN-CW2ME	30 minutes	15 1/50	Single-Phase 220	50	0.18	100 14.2	125 17.7	1200	1.5
					60	0.20		105 14.9	1450	
				Single-Phase 230	50	0.19	100 14.2	125 17.7	1200	
					60	0.20		105 14.9	1450	
TP	3IK15GN-SW2M	Continuous	15 1/50	Three-Phase 200	50	0.17	110 15.6	110 15.6	1350	-
					60	0.15	85 12.0	100 14.2	1600	
				Three-Phase 220	60	0.16	100 14.2	100 14.2	1650	
Three-Phase 230	0.17									

- This type of motor does not contain a built-in friction brake mechanism similar to the reversible motors.
- The **U** and **E** at the end of the model name indicate that the unit includes a capacitor. These letters are not listed on the motor nameplate. When the motor is approved under various safety standards, the model name on the nameplate is the approved model name. → Page H-11
- Details of safety standards → Page H-2

TP: Contains a built-in thermal protector (automatic return type). If a motor overheats for any reason, the thermal protector is activated and the motor is stopped. (The power supply to the electromagnetic brake is kept and the brake is released.)
When the motor temperature drops, the thermal protector closes and the motor restarts. Be sure to turn the motor power off before inspecting.

● Electromagnetic Brake (Power Off Activated Type)

Motor Model	Voltage VAC	Frequency Hz	Current A	Input W	Holding Brake Torque mN·m oz·in	
3RK15GN-AW2MU 3RK15A-AW2MU	Single-Phase 110	60	0.09	7	80	
	Single-Phase 115				11.3	
3RK15GN-CW2ME 3RK15A-CW2ME	Single-Phase 220	50	0.05	7	80	
		60				11.3
	Single-Phase 230	50			80	11.3
		60				
3IK15GN-SW2M 3IK15A-SW2M	Single-Phase 200	50	0.05	7	80	
	Single-Phase 220	60			11.3	
		Single-Phase 230			60	

High Strength, Long Life, Low Noise
V Series

Highest Maximum Permissible torque, 10,000 hours of life and quiet operation. For more details on V Series see page C-149 or visit www.orientalmotor.com.



Product Line

Motor (RoHS)

Model	
Pinion Shaft Type	Round Shaft Type
3RK15GN-AW2MU	3RK15A-AW2MU
3RK15GN-CW2ME	3RK15A-CW2ME
3IK15GN-SW2M	3IK15A-SW2M

The following items are included in each product.
 Motor, Capacitor*, Capacitor Cap*, Operating Manual
 *Only for single-phase motors

Parallel Shaft Gearhead (Sold separately) (RoHS)

Gearhead Type		Gearhead Model	Gear Ratio
Parallel Shaft	Long Life, Low Noise GN-S Gearhead	3GN□SA	3, 3.6, 5, 6, 7.5, 9, 12.5, 15, 18, 25, 30, 36, 50, 60, 75, 90, 100, 120, 150, 180
		3GN10XS (Decimal Gearhead)	

The following items are included in each product.
 Gearhead, Mounting Screws, Operating Manual

The following gearheads are also available. For details, please refer to website (www.orientalmotor.com) or contact the nearest Oriental Motor sales office.

Gearhead Type		Gearhead Model	Gear Ratio
Parallel Shaft	(RoHS) GN-K Gearhead	3GN□KA	3~180
		3GN10XK (Decimal Gearhead)	

Gearmotor – Torque Table

- Enter the gear ratio in the box (□) within the gearhead model name.
- A colored background (□) indicates gear shaft rotation in the same direction as the motor shaft, while the others rotate in the opposite direction.
- The speed is calculated by dividing the motor's synchronous speed (50 Hz: 1500 r/min, 60 Hz: 1800 r/min) by the gear ratio. The actual speed is 2~20% less than the displayed value, depending on the load.
- To reduce the speed beyond the gear ratio in the table, attach a decimal gearhead (gear ratio 10:1) between the gearhead and the motor. In that case, the permissible torque is 5 N·m (44 lb-in).

◇ 50 Hz

Unit = Upper values: N·m/Lower values: lb-in

Model Motor/ Gearhead	Speed r/min	Gear Ratio																			
		500	417	300	250	200	167	120	100	83	60	50	42	30	25	20	17	15	12.5	10	8.3
3RK15GN-CW2ME / 3GN□SA	Gear Ratio	3	3.6	5	6	7.5	9	12.5	15	18	25	30	36	50	60	75	90	100	120	150	180
		0.30 2.6	0.36 3.1	0.51 4.5	0.61 5.3	0.76 6.7	0.91 8.0	1.3 11.5	1.5 13.2	1.8 15.9	2.3 20	2.7 23	3.3 29	4.1 36	5 44	5 44	5 44	5 44	5 44	5 44	5 44
3IK15GN-SW2M / 3GN□SA	Gear Ratio	3	3.6	5	6	7.5	9	12.5	15	18	25	30	36	50	60	75	90	100	120	150	180
		0.27 2.3	0.32 2.8	0.45 3.9	0.53 4.6	0.67 5.9	0.80 7.0	1.1 9.7	1.3 11.5	1.6 14.1	2.0 17.7	2.4 21	2.9 25	3.6 31	4.4 38	5 44	5 44	5 44	5 44	5 44	5 44

◇ 60 Hz

Unit = Upper values: N·m/Lower values: lb-in

Model Motor/ Gearhead	Speed r/min	Gear Ratio																			
		600	500	360	300	240	200	144	120	100	72	60	50	36	30	24	20	18	15	12	10
3RK15GN-AW2MU 3RK15GN-CW2ME / 3GN□SA	Gear Ratio	3	3.6	5	6	7.5	9	12.5	15	18	25	30	36	50	60	75	90	100	120	150	180
		0.26 2.3	0.31 2.7	0.43 3.8	0.51 4.5	0.64 5.6	0.77 6.8	1.1 9.7	1.3 11.5	1.5 13.2	1.9 16.8	2.3 20	2.8 24	3.5 30	4.2 37	5 44	5 44	5 44	5 44	5 44	5 44
3IK15GN-SW2M / 3GN□SA	Gear Ratio	3	3.6	5	6	7.5	9	12.5	15	18	25	30	36	50	60	75	90	100	120	150	180
		0.24 2.1	0.29 2.5	0.41 3.6	0.49 4.3	0.61 5.3	0.73 6.4	1.0 8.8	1.2 10.6	1.5 13.2	1.8 15.9	2.2 19.4	2.6 23	3.3 29	4.0 35	5 44	5 44	5 44	5 44	5 44	5 44

Permissible Overhung Load and Permissible Thrust Load

Motor (Round shaft type) → Page C-17

Gearhead → Page C-17

Permissible Load Inertia J of Gearhead

→ Page C-18

Enter the gear ratio in the box (□) within the model name.

Starting and Braking Characteristics (Reference values)

Single-Phase Motor

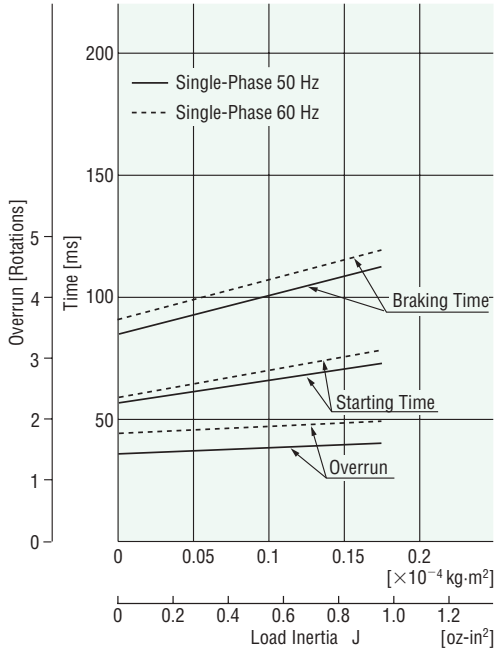

Three-Phase Motor

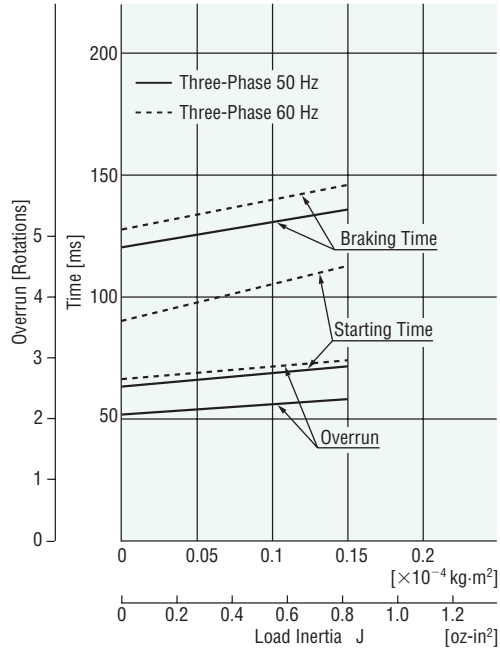

Dimensions Unit = mm (in.)

● Mounting screws are included with gearheads. Dimensions for mounting screws → Page C-280

Motor/Gearhead

Mass: Motor 1.3 kg (2.9 lb.)
Gearhead 0.55 kg (1.21 lb.)

Motor Model	Gearhead Model	Gear Ratio	L	DXF
3RK15GN-AW2MU 3RK15GN-CW2ME 3IK15GN-SW2M	3GN□SA	3~18	32 (1.26)	A464AU
		25~180	42 (1.65)	A464BU

● Enter the gear ratio in the box (□) within the model name.

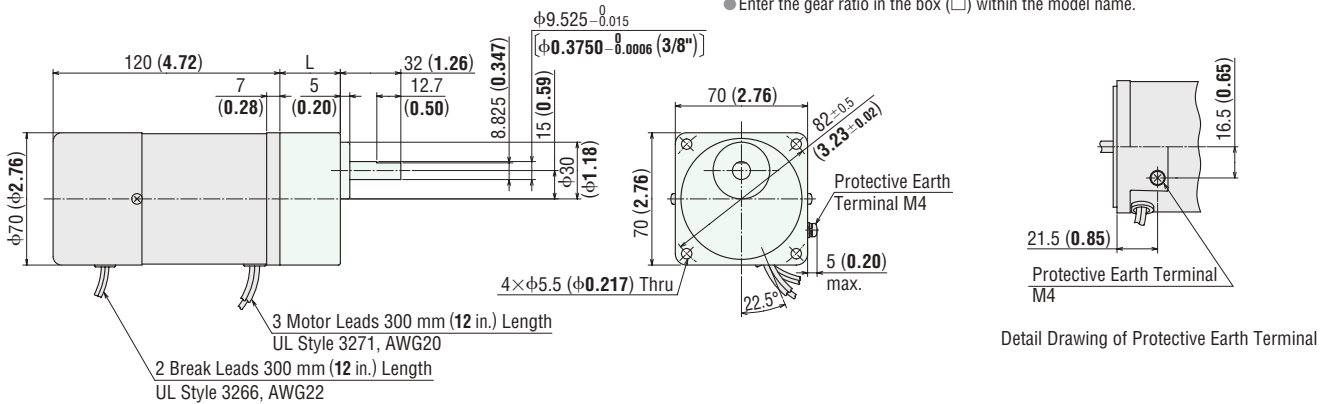

◇ Shaft Section of Round Shaft Type

The motor's dimensions (excluding the shaft section) are the same as those of the pinion shaft types.

Mass: 1.3 kg (2.9 lb.)

DXF A465

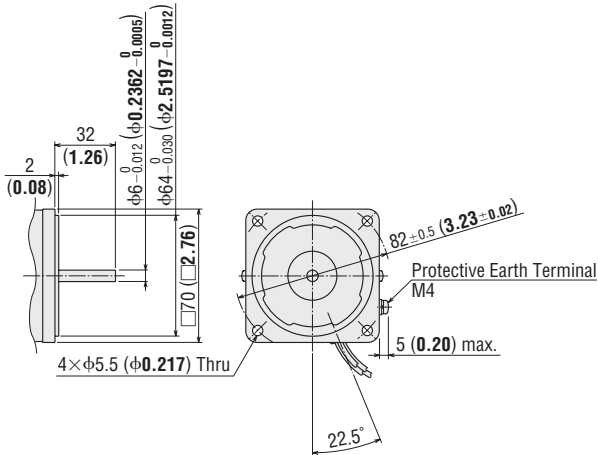

◇ Decimal Gearhead

Can be connected to **GN** pinion shaft type.

3GN10XS

Mass: 0.3 kg (0.66 lb.)

DXF A009

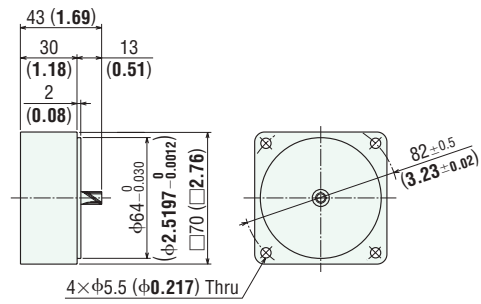

◇ Capacitor

(Included with single-phase motors)

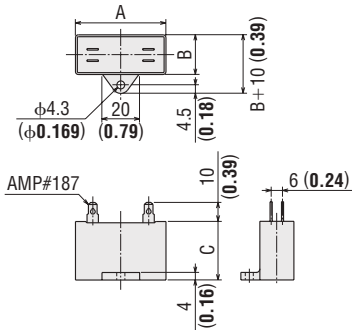

◇ Capacitor Dimensions Unit = mm (in.)

Model		Capacitor Model	A	B	C	Mass g (oz.)	Capacitor Cap
Pinion Shaft Type	Round Shaft Type						
3RK15GN-AW2MU	3RK15A-AW2MU	CH60CFAUL2	38 (1.50)	21 (0.83)	31 (1.22)	35 (1.24)	Included
3RK15GN-CW2ME	3RK15A-CW2ME	CH15BFAUL	38 (1.50)	21 (0.83)	31 (1.22)	37 (1.31)	

■ Connection Diagrams

→ Page C-114

Accessories and Peripheral Equipment

Instantaneous Stop Brake Pack

→ Page C-253



Accessories

→ Page C-263



Power Off Activated Type Electromagnetic Brake Motors

25 W (1/30 HP)

Frame Size: □80 mm (□3.15 in.)

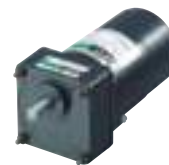

(Gearhead sold separately)

6 W
(1/125 HP)

15 W
(1/50 HP)

25 W
(1/30 HP)

40 W
(1/19 HP)

60 W
(1/12 HP)

90 W
(1/8 HP)

200 W
(1/4 HP)

Specifications

● Motor (RoHS)



Model		Rating	Output Power W HP	Voltage VAC	Frequency Hz	Current A	Starting Torque mN·m oz·in	Rated Torque mN·m oz·in	Rated Speed r/min	Capacitor μF
Pinion Shaft Type	Round Shaft Type									
ⓉP 4RK25GN-AW2MU	4RK25A-AW2MU	30 minutes	25 1/30	Single-Phase 110	60	0.54	140 19.8	170 24	1450	8.0
				Single-Phase 115						
ⓉP 4RK25GN-CW2ME	4RK25A-CW2ME	30 minutes	25 1/30	Single-Phase 220	60	0.28	140 19.8	170 24	1450	2.0
				Single-Phase 230						
				60	0.28	140 19.8	170 24	1450		
ⓉP 4IK25GN-SW2M	4IK25A-SW2M	Continuous	25 1/30	Three-Phase 200	50	0.23	240 34	190 26	1300	-
					60		0.21	160 22	160 22	
				60	0.20	160	150	1600		
					0.21	22	21			

- This type of motor does not contain a built-in friction brake mechanism similar to the reversible motors.
- The **U** and **E** at the end of the model name indicate that the unit includes a capacitor. These letters are not listed on the motor nameplate. When the motor is approved under various safety standards, the model name on the nameplate is the approved model name. → Page H-11
- Details of safety standards → Page H-2

ⓉP: Contains a built-in thermal protector (automatic return type). If a motor overheats for any reason, the thermal protector is activated and the motor is stopped. (The power supply to the electromagnetic brake is kept and the brake is released.)
When the motor temperature drops, the thermal protector closes and the motor restarts. Be sure to turn the motor power off before inspecting.

Electromagnetic Brake (Power Off Activated Type)

Motor Model	Voltage VAC	Frequency Hz	Current A	Input W	Holding Brake Torque mN·m oz·in
4RK25GN-AW2MU 4RK25A-AW2MU	Single-Phase 110	60	0.09	6	100
	Single-Phase 115				14.2
4RK25GN-CW2ME 4RK25A-CW2ME	Single-Phase 220	60	0.05	7	100
	Single-Phase 230				14.2
	60				
4IK25GN-SW2M 4IK25A-SW2M	Single-Phase 200	60	0.05	7	100
	Single-Phase 220				14.2
	Single-Phase 230				

Product Line

● Motor (RoHS)

Model	
Pinion Shaft Type	Round Shaft Type
4RK25GN-AW2MU	4RK25A-AW2MU
4RK25GN-CW2ME	4RK25A-CW2ME
4IK25GN-SW2M	4IK25A-SW2M

The following items are included in each product.
Motor, Capacitor*, Capacitor Cap*, Operating Manual
*Only for single-phase motors

High Strength, Long Life, Low Noise V Series

Highest Maximum Permissible torque, 10,000 hours of life and quiet operation. For more details on **V** Series see page C-149 or visit www.orientalmotor.com.



● Parallel Shaft Gearhead/Right-Angle Gearhead (Sold separately) (RoHS)

Gearhead Type		Gearhead Model	Gear Ratio
Parallel Shaft	Long Life, Low Noise GN-S Gearhead	4GN□SA	3, 3.6, 5, 6, 7.5, 9, 12.5, 15, 18, 25, 30, 36, 50, 60, 75, 90, 100, 120, 150, 180
	Hollow Shaft	4GN□RH	
Right-Angle Shaft	Solid Shaft	4GN□RAA	
Parallel Shaft	Long Life, Low Noise GN-S Gearhead	4GN10XS (Decimal Gearhead)	

● Enter the gear ratio in the box (□) within the model name.

The following items are included in each product.

- Parallel Shaft Gearhead
Gearhead, Mounting Screws, Operating Manual
- Hollow Shaft Gearhead
Gearhead, Mounting Screws, Parallel Key, Safety Cover (with screws), Gasket, Operating Manual
- Solid Shaft Gearhead
Gearhead, Mounting Screws, Gasket, Operating Manual

● The following gearheads are also available. For details, please refer to website (www.orientalmotor.com) or contact the nearest Oriental Motor sales office.

Gearhead Type		Gearhead Model	Gear Ratio
Parallel Shaft	(RoHS) GN-K Gearhead	4GN□KA	3~180
		4GN10XK (Decimal Gearhead)	

● Enter the gear ratio in the box (□) within the model name.

■ Gearmotor – Torque Table

- Enter the gear ratio in the box (□) within the gearhead model name.
- A colored background (□) indicates gear shaft rotation in the same direction as the motor shaft, while the others rotate in the opposite direction.
- The speed is calculated by dividing the motor's synchronous speed (50 Hz: 1500 r/min, 60 Hz: 1800 r/min) by the gear ratio. The actual speed is 2~20% less than the displayed value, depending on the load.
- To reduce the speed beyond the gear ratio in the table, attach a decimal gearhead (gear ratio 10:1) between the gearhead and the motor. In that case, the permissible torque is 8 N·m (70 lb-in). When a gearhead of 25:1~36:1 is connected, the value for permissible torque is 6 N·m (53 lb-in).

◇ 50 Hz

Unit = Upper values: N-m/Lower values: lb-in

Model Motor/ Gearhead	Speed r/min	500	417	300	250	200	167	120	100	83	60	50	42	30	25	20	17	15	12.5	10	8.3
	Gear Ratio	3	3.6	5	6	7.5	9	12.5	15	18	25	30	36	50	60	75	90	100	120	150	180
4RK25GN-CW2ME / 4GN□SA	0.50 4.4	0.60 5.3	0.83 7.3	1.0 8.8	1.2 10.6	1.5 13.2	2.1 18.5	2.5 22	3.0 26	3.7 32	4.5 39	5.4 47	6.8 60	8 70	8 70	8 70	8 70	8 70	8 70	8 70	8 70
4IK25GN-SW2M / 4GN□SA	0.46 4.0	0.55 4.8	0.77 6.8	0.92 8.1	1.2 10.6	1.4 12.3	1.9 16.8	2.3 20	2.8 24	3.5 30	4.2 37	5.0 44	6.3 55	7.5 66	8 70	8 70	8 70	8 70	8 70	8 70	8 70

◇ 60 Hz

Unit = Upper values: N-m/Lower values: lb-in

Model Motor/ Gearhead	Speed r/min	600	500	360	300	240	200	144	120	100	72	60	50	36	30	24	20	18	15	12	10
	Gear Ratio	3	3.6	5	6	7.5	9	12.5	15	18	25	30	36	50	60	75	90	100	120	150	180
4RK25GN-AW2MU 4RK25GN-CW2ME / 4GN□SA	0.41 3.6	0.50 4.4	0.69 6.1	0.83 7.3	1.0 8.8	1.2 10.6	1.7 15.0	2.1 18.5	2.5 22	3.1 27	3.7 32	4.5 39	5.6 49	6.7 59	8 70	8 70	8 70	8 70	8 70	8 70	8 70
4IK25GN-SW2M (200 VAC) / 4GN□SA	0.39 3.4	0.47 4.1	0.65 5.7	0.78 6.9	0.97 8.5	1.2 10.6	1.6 14.1	1.9 16.8	2.3 20	2.9 25	3.5 30	4.2 37	5.3 46	6.3 55	7.9 69	8 70	8 70	8 70	8 70	8 70	8 70
4IK25GN-SW2M (220/230 VAC) / 4GN□SA	0.36 3.1	0.44 3.8	0.61 5.3	0.73 6.4	0.91 8.0	1.1 9.7	1.5 13.2	1.8 15.9	2.2 19.4	2.7 23	3.3 29	3.9 34	5.0 44	5.9 52	7.4 65	8 70	8 70	8 70	8 70	8 70	8 70

■ Gearmotor – Torque Table When Right-Angle Gearhead is Attached

→ Page C-238

■ Permissible Overhung Load and Permissible Thrust Load

Motor (Round shaft type) → Page C-17

Gearhead → Page C-17

■ Permissible Load Inertia J of Gearhead

→ Page C-18

Starting and Braking Characteristics (Reference values)

Single-Phase Motor

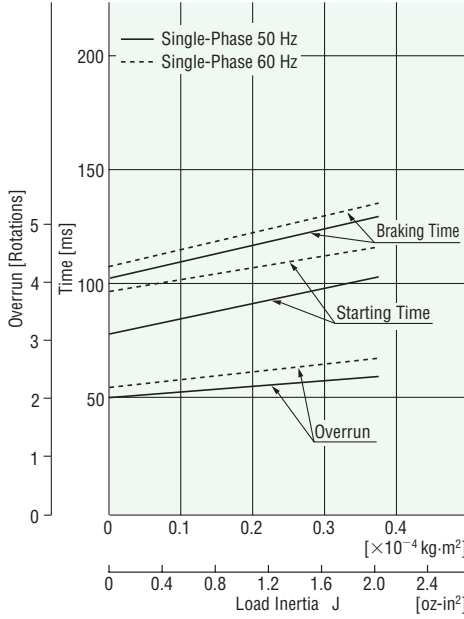

Three-Phase Motor

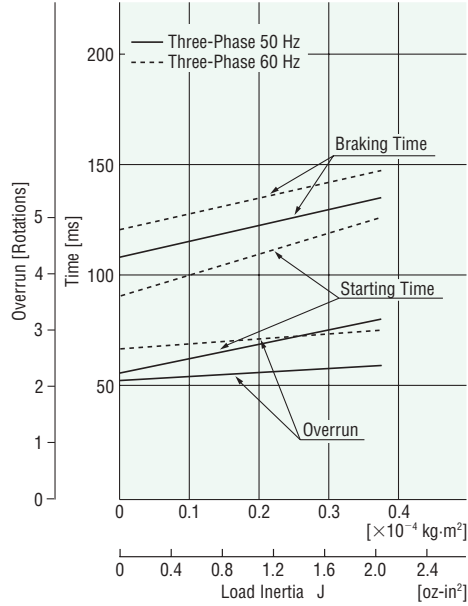

Dimensions Unit = mm (in.)

● Mounting screws are included with gearheads. Dimensions for mounting screws → Page C-280

Motor/Gearhead

Mass: Motor 2.0 kg (4.4 lb.)
Gearhead 0.65 kg (1.43 lb.)

Motor Model	Gearhead Model	Gear Ratio	L	DXF
4RK25GN-AW2MU 4RK25GN-CW2ME 4IK25GN-SW2M	4GN□SA	3~18	32 (1.26)	A466AU
		25~180	42.5 (1.67)	A466BU

● Enter the gear ratio in the box (□) within the model name.

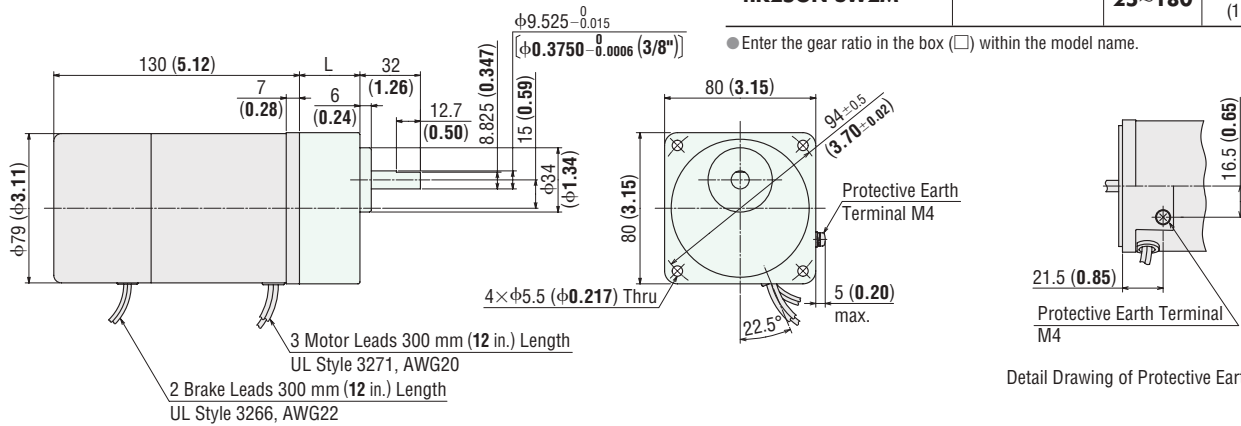

Shaft Section of Round Shaft Type

The motor's dimensions (excluding the shaft section) are the same as those of the pinion shaft types.

Mass: 2.0 kg (4.4 lb.)

DXF A467

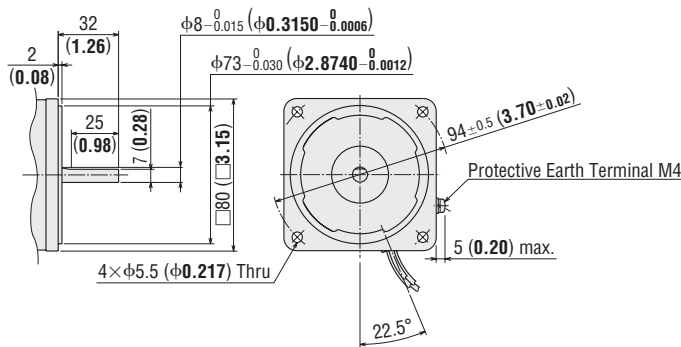

Decimal Gearhead

Can be connected to GN pinion shaft type.

4GN10XS

Mass: 0.4 kg (0.88 lb.)

DXF A013

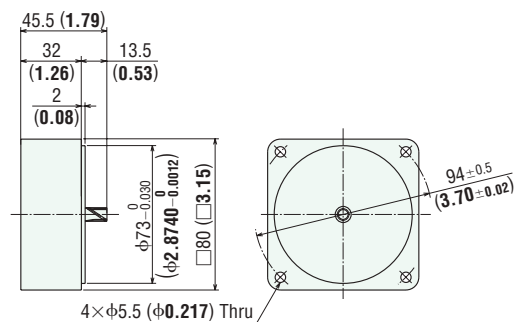

◇ Capacitor
(Included with single-phase motors)

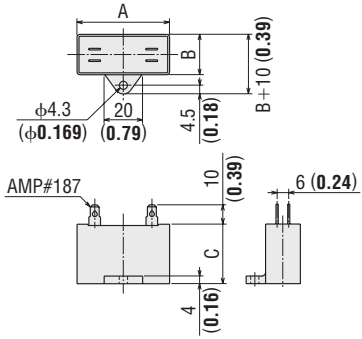

◇ Capacitor Dimensions Unit = mm (in.)

Model		Capacitor Model	A	B	C	Mass g (oz.)	Capacitor Cap
Pinion Shaft Type	Round Shaft Type						
4RK25GN-AW2MU	4RK25A-AW2MU	CH80CFAUL2	48 (1.89)	21 (0.83)	31 (1.22)	41 (1.45)	Included
4RK25GN-CW2ME	4RK25A-CW2ME	CH20BFAUL	48 (1.89)	19 (0.75)	29 (1.14)	36 (1.27)	

Connection Diagrams

→ Page C-114

Gearhead, Linear Head, Accessories and Peripheral Equipment

- Space-Saving Right-Angle Gearheads** → Page C-227
- Linear Motion Linear Heads** → Page C-247
- Instantaneous Stop Brake Pack** → Page C-253
- Accessories** → Page C-263

- Introduction
- Induction Motors
- Reversible Motors
- Electromagnetic Brake Motors
- V Series
- Clutch & Brake Motors
- Synchronous Motors
- Low-Speed Synchronous Motors
- Waterright Dust-Resistant Motors
- Torque Motors
- Right-Angle Gearheads
- Linear Heads
- Brake Pack
- Accessories
- Installation

Power Off Activated Type Electromagnetic Brake Motors

40 W (1/19 HP)

Frame Size: □90 mm (□3.54 in.)



(Gearhead sold separately)

6 W
(1/125 HP)

15 W
(1/50 HP)

25 W
(1/30 HP)

40 W
(1/19 HP)

60 W
(1/12 HP)

90 W
(1/8 HP)

200 W
(1/4 HP)

Specifications

● Motor (RoHS)



Model		Rating	Output Power W HP	Voltage	Frequency Hz	Current A	Starting Torque mN·m oz·in	Rated Torque mN·m oz·in	Rated Speed r/min	Capacitor μF					
Pinion Shaft Type	Round Shaft Type			VAC											
ⓉP 5RK40GN-AW2MU	5RK40A-AW2MU	30 minutes	40 1/19	Single-Phase 110	60	0.81	260 36	270 38	1450	12					
				Single-Phase 115											
ⓉP 5RK40GN-CW2ME	5RK40A-CW2ME	30 minutes	40 1/19	Single-Phase 220	50	0.38	260 36	315 44	1250	3.5					
				Single-Phase 230							60	0.43	260 36	260 36	1500
											Three-Phase 200	50	0.32	400 56	300 42
ⓉP 5IK40GN-SW2M	5IK40A-SW2M	Continuous	40 1/19	Three-Phase 220	60	0.30	260 36	260 36	1550	-					
				Three-Phase 230							60	0.30	260 36	260 36	1600
											Three-Phase 230	60	0.31	260 36	260 36

- This type of motor does not contain a built-in friction brake mechanism similar to the reversible motors.
- The **U** and **E** at the end of the model name indicate that the unit includes a capacitor. These letters are not listed on the motor nameplate. When the motor is approved under various safety standards, the model name on the nameplate is the approved model name. → Page H-11
- Details of safety standards → Page H-2

ⓉP: Contains a built-in thermal protector (automatic return type). If a motor overheats for any reason, the thermal protector is activated and the motor is stopped. (The power supply to the electromagnetic brake is kept and the brake is released.)
When the motor temperature drops, the thermal protector closes and the motor restarts. Be sure to turn the motor power off before inspecting.

● Electromagnetic Brake (Power Off Activated Type)

Motor Model	Voltage VAC	Frequency Hz	Current A	Input W	Holding Brake Torque mN·m oz·in	
5RK40GN-AW2MU 5RK40A-AW2MU	Single-Phase 110	60	0.09	6	200 28	
	Single-Phase 115					
5RK40GN-CW2ME 5RK40A-CW2ME	Single-Phase 220	50	0.05	7	200 28	
	Single-Phase 230					60
						50
5IK40GN-SW2M 5IK40A-SW2M	Single-Phase 200	60	0.05	7	200 28	
	Single-Phase 220					60
						Single-Phase 230

High Strength, Long Life, Low Noise
V Series

Highest Maximum Permissible torque, 10,000 hours of life and quiet operation. For more details on V Series see page C-149 or visit www.orientalmotor.com.



Product Line

● Motor (RoHS)

Model	
Pinion Shaft Type	Round Shaft Type
5RK40GN-AW2MU	5RK40A-AW2MU
5RK40GN-CW2ME	5RK40A-CW2ME
5IK40GN-SW2M	5IK40A-SW2M

The following items are included in each product.
 Motor, Capacitor*, Capacitor Cap*, Operating Manual
 *Only for single-phase motors

● Parallel Shaft Gearhead/Right-Angle Gearhead (Sold separately) (RoHS)

Gearhead Type		Gearhead Model	Gear Ratio
Parallel Shaft	Long Life, Low Noise GN-S Gearhead	5GN□SA	3, 3.6, 5, 6, 7.5, 9, 12.5, 15, 18, 25, 30, 36, 50, 60, 75, 90, 100, 120, 150, 180
	Right-Angle Shaft	Hollow Shaft	
Solid Shaft		5GN□RAA	
Parallel Shaft	Long Life, Low Noise GN-S Gearhead	5GN10XS (Decimal Gearhead)	

The following items are included in each product.

- Parallel Shaft Gearhead
Gearhead, Mounting Screws, Operating Manual
- Hollow Shaft Gearhead
Gearhead, Mounting Screws, Parallel Key, Safety Cover (with screws), Gasket, Operating Manual
- Solid Shaft Gearhead
Gearhead, Mounting Screws, Gasket, Operating Manual

● The following gearheads are also available. For details, please refer to website (www.orientalmotor.com) or contact the nearest Oriental Motor sales office.

Gearhead Type		Gearhead Model	Gear Ratio
Parallel Shaft	(RoHS)	5GN□KA	3~180
	GN-K Gearhead	5GN10XK (Decimal Gearhead)	

Gearmotor – Torque Table

- Enter the gear ratio in the box (□) within the gearhead model name.
- A colored background (□) indicates gear shaft rotation in the same direction as the motor shaft, while the others rotate in the opposite direction.
- The speed is calculated by dividing the motor's synchronous speed (50 Hz: 1500 r/min, 60 Hz: 1800 r/min) by the gear ratio.
The actual speed is 2~20% less than the displayed value, depending on the load.
- To reduce the speed beyond the gear ratio in the table, attach a decimal gearhead (gear ratio 10:1) between the gearhead and the motor.
In that case, the permissible torque is 10 N·m (88 lb-in).

◇ 50 Hz

Unit = Upper values: N·m/Lower values: lb-in

Model Motor/ Gearhead	Speed r/min	500	417	300	250	200	167	120	100	83	60	50	42	30	25	20	17	15	12.5	10	8.3
	Gear Ratio	3	3.6	5	6	7.5	9	12.5	15	18	25	30	36	50	60	75	90	100	120	150	180
5RK40GN-CW2ME / 5GN□SA	0.77 6.8	0.92 8.1	1.3 11.5	1.5 13.2	1.9 16.8	2.3 20	3.2 28	3.8 33	4.6 40	5.7 50	6.9 61	8.3 73	10 88	10 88	10 88	10 88	10 88	10 88	10 88	10 88	10 88
5IK40GN-SW2M / 5GN□SA	0.73 6.4	0.87 7.6	1.2 10.6	1.5 13.2	1.8 15.9	2.2 19.4	3.0 26	3.6 31	4.4 38	5.5 48	6.6 58	7.9 69	9.9 87	10 88	10 88	10 88	10 88	10 88	10 88	10 88	10 88

◇ 60 Hz

Unit = Upper values: N·m/Lower values: lb-in

Model Motor/ Gearhead	Speed r/min	600	500	360	300	240	200	144	120	100	72	60	50	36	30	24	20	18	15	12	10
	Gear Ratio	3	3.6	5	6	7.5	9	12.5	15	18	25	30	36	50	60	75	90	100	120	150	180
5RK40GN-AW2MU / 5GN□SA	0.66 5.8	0.79 6.9	1.1 9.7	1.3 11.5	1.6 14.1	2.0 17.7	2.7 23	3.3 29	3.9 34	4.9 43	5.9 52	7.1 62	8.9 78	10 88	10 88	10 88	10 88	10 88	10 88	10 88	10 88
5RK40GN-CW2ME 5IK40GN-SW2M / 5GN□SA	0.63 5.5	0.76 6.7	1.1 9.7	1.3 11.5	1.6 14.1	1.9 16.8	2.6 23	3.2 28	3.8 33	4.7 41	5.7 50	6.8 60	8.6 76	10 88	10 88	10 88	10 88	10 88	10 88	10 88	10 88

● Enter the gear ratio in the box (□) within the model name.

■ Gearmotor – Torque Table When Right-Angle Gearhead is Attached

→ Page C-238

■ Permissible Overhung Load and Permissible Thrust Load

Motor (Round shaft type) → Page C-17

Gearhead → Page C-17

■ Permissible Load Inertia J of Gearhead

→ Page C-18

■ Starting and Braking Characteristics (Reference values)

● Single-Phase Motor

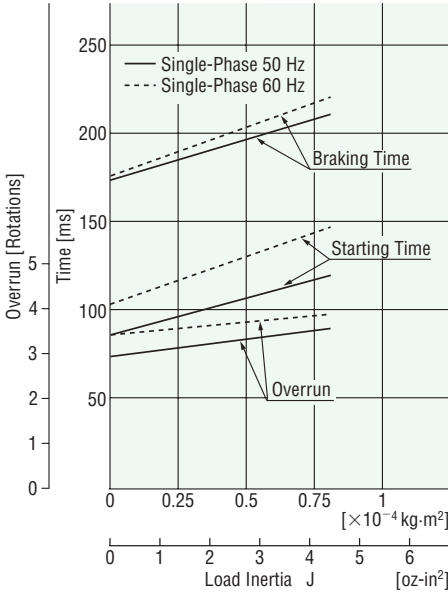

● Three-Phase Motor

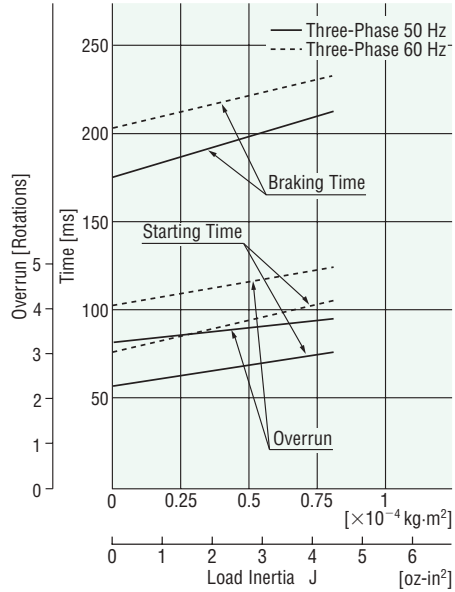

■ Dimensions Unit = mm (in.)

● Mounting screws are included with gearheads. Dimensions for mounting screws → Page C-280

◇ Motor/Gearhead

Mass: Motor 2.8 kg (6.2 lb.)

Gearhead 1.5 kg (3.3 lb.)

Motor Model	Gearhead Model	Gear Ratio	L	DXF
5RK40GN-AW2MU 5RK40GN-CW2ME 5IK40GN-SW2M	5GN□SA	3~18	42 (1.65)	A468AU
25~180		60 (2.36)	A468BU	

● Enter the gear ratio in the box (□) within the model name.

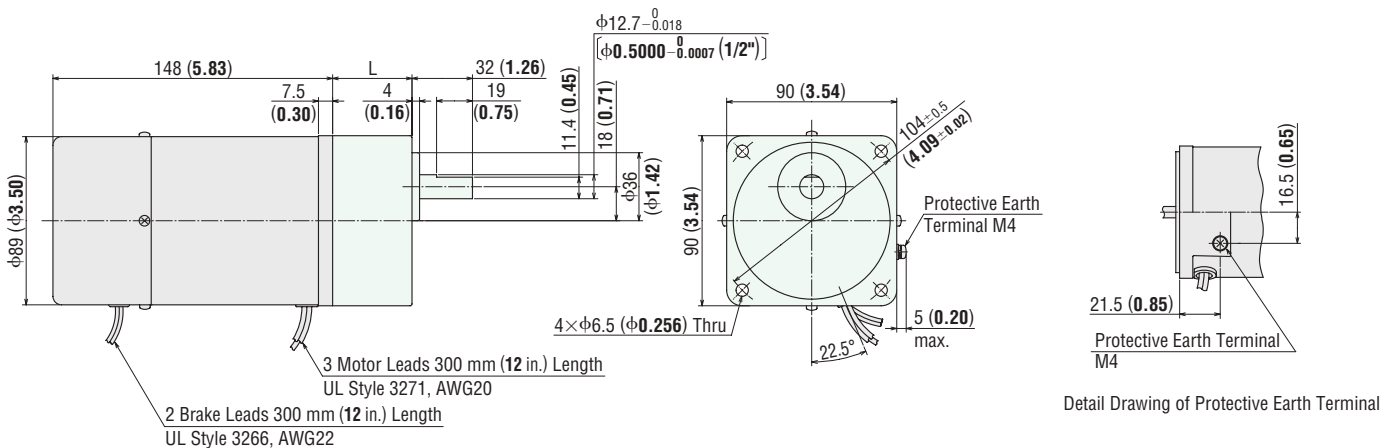

Detail Drawing of Protective Earth Terminal

◇ Shaft Section of Round Shaft Type

The motor's dimensions (excluding the shaft section) are the same as those of the pinion shaft types.

Mass: 2.8 kg (6.2 lb.)

DXF A469

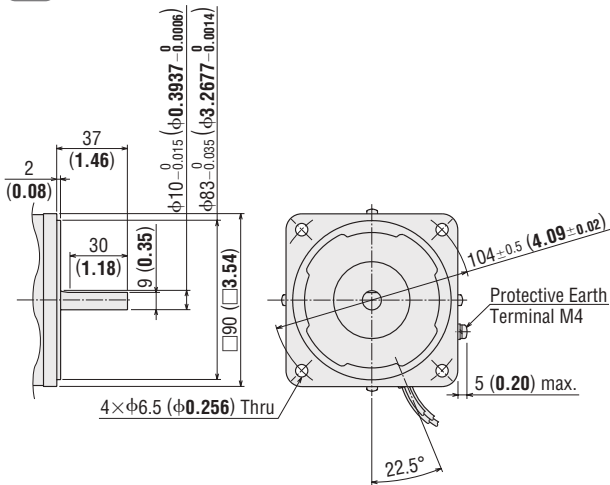

◇ Decimal Gearhead

Can be connected to **GN** pinion shaft type.

5GN10XS

Mass: 0.6 kg (1.32 lb.)

DXF A022

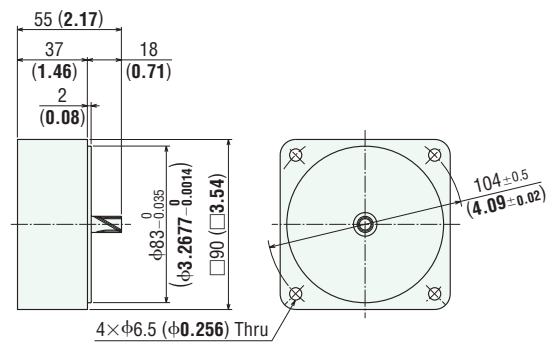

◇ Capacitor (Included with single-phase motors)

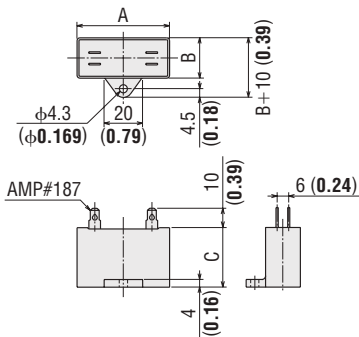

◇ Capacitor Dimensions Unit = mm (in.)

Model		Capacitor Model	A	B	C	Mass g (oz.)	Capacitor Cap
Pinion Shaft Type	Round Shaft Type						
5RK40GN-AW2MU	5RK40A-AW2MU	CH120CFAUL2	58 (2.28)	22 (0.87)	35 (1.38)	60 (2.1)	Included
5RK40GN-CW2ME	5RK40A-CW2ME	CH35BFAUL	58 (2.28)	22 (0.87)	35 (1.38)	59 (2.1)	

■ Connection Diagrams

→ Page C-114

Gearhead, Accessories and Peripheral Equipment

Space-Saving
Right-Angle Gearheads
→ Page C-227



Instantaneous Stop
Brake Pack
→ Page C-253



Accessories
→ Page C-263



Power Off Activated Type Electromagnetic Brake Motors

60 W (1/12 HP)

Frame Size: □90 mm (□3.54 in.)



(Gearhead sold separately)

Specifications

● Motor (RoHS)



Model		Rating	Output Power W HP	Voltage	Frequency Hz	Current A	Starting Torque mN·m oz-in	Rated Torque mN·m oz-in	Rated Speed r/min	Capacitor μF
Pinion Shaft Type	Round Shaft Type			VAC						
TP	5RK60GE-AW2MU	30 minutes	60 1/12	Single-Phase 110	60	1.24	380 53	405 57	1450	20
				Single-Phase 115						
TP	5RK60GE-CW2ME	30 minutes	60 1/12	Single-Phase 220	60	0.61	380 53	405 57	1450	5.0
				Single-Phase 230	50	0.59	470 66	490 69	1200	
					60	0.61	380 53	405 57	1450	
TP	5IK60GE-SW2M	Continuous	60 1/12	Three-Phase 200	50	0.50	600 85	450 63	1300	-
					60	0.43	500 71	380 53	1550	
				Three-Phase 220	60	0.45	500	380	1600	
						0.46	71	53		

- This type of motor does not contain a built-in friction brake mechanism similar to the reversible motors.
- The **U** and **E** at the end of the model name indicate that the unit includes a capacitor. These letters are not listed on the motor nameplate. When the motor is approved under various safety standards, the model name on the nameplate is the approved model name. → Page H-11
- Details of safety standards → Page H-2

TP: Contains a built-in thermal protector (automatic return type). If a motor overheats for any reason, the thermal protector is activated and the motor is stopped. (The power supply to the electromagnetic brake is kept and the brake is released.)
When the motor temperature drops, the thermal protector closes and the motor restarts. Be sure to turn the motor power off before inspecting.

Electromagnetic Brake (Power Off Activated Type)

Motor Model	Voltage VAC	Frequency Hz	Current A	Input W	Holding Brake Torque mN·m oz-in	
5RK60GE-AW2MU 5RK60A-AW2MU	Single-Phase 110	60	0.13	10	500	
	Single-Phase 115				71	
5RK60GE-CW2ME 5RK60A-CW2ME	Single-Phase 220	60	0.07	10	500	
	Single-Phase 230				50	71
					60	
5IK60GE-SW2M 5IK60A-SW2M	Single-Phase 200	50	0.07	10	500	
		60				
	Single-Phase 220	60				71
						Single-Phase 230

High Strength, Long Life, Low Noise
V Series

Highest Maximum Permissible torque, 10,000 hours of life and quiet operation. For more details on V Series see page C-149 or visit www.orientalmotor.com.



Product Line

● Motor (RoHS)

Model	
Pinion Shaft Type	Round Shaft Type
5RK60GE-AW2MU	5RK60A-AW2MU
5RK60GE-CW2ME	5RK60A-CW2ME
5IK60GE-SW2M	5IK60A-SW2M

The following items are included in each product.

Motor, Capacitor*, Capacitor Cap*, Operating Manual
*Only for single-phase motors

● Parallel Shaft Gearhead/Right-Angle Gearhead (Sold separately) (RoHS)

Gearhead Type		Gearhead Model	Gear Ratio
Parallel Shaft	Long Life GE-S Gearhead	5GE□SA	3, 3.6, 5, 6, 7.5, 9, 12.5, 15, 18, 25, 30, 36, 50, 60, 75, 90, 100, 120, 150, 180
Right-Angle Shaft	Hollow Shaft	5GE□RH	
	Solid Shaft	5GE□RAA	
Parallel Shaft	Long Life GE-S Gearhead	5GE10XS (Decimal Gearhead)	

● Enter the gear ratio in the box (□) within the model name.

The following items are included in each product.

- Parallel Shaft Gearhead
Gearhead, Mounting Screws, Parallel Key, Operating Manual
- Hollow Shaft Gearhead
Gearhead, Mounting Screws, Parallel Key, Safety Cover (with screws), Gasket, Operating Manual
- Solid Shaft Gearhead
Gearhead, Mounting Screws, Parallel Key, Gasket, Operating Manual

Gearmotor – Torque Table

- Enter the gear ratio in the box (□) within the gearhead model name.
- A colored background (□) indicates gear shaft rotation in the same direction as the motor shaft, while the others rotate in the opposite direction.
- The speed is calculated by dividing the motor's synchronous speed (50 Hz: 1500 r/min, 60 Hz: 1800 r/min) by the gear ratio.
The actual speed is 2~20% less than the displayed value, depending on the load.
- To reduce the speed beyond the gear ratio in the table, attach a decimal gearhead (gear ratio 10:1) between the gearhead and the motor.
In that case, the permissible torque is 20 N·m (177 lb-in).

◇ 50 Hz

Unit = Upper values: N·m/Lower values: lb-in

Model Motor/ Gearhead	Speed r/min	500	417	300	250	200	167	120	100	83	60	50	42	30	25	20	17	15	12.5	10	8.3
		Gear Ratio	3	3.6	5	6	7.5	9	12.5	15	18	25	30	36	50	60	75	90	100	120	150
5RK60GE-CW2ME / 5GE□SA	1.2 10.6	1.4 12.3	2.0 17.7	2.4 21	3.0 26	3.6 31	4.5 39	5.4 47	6.4 56	8.1 71	9.7 85	11.6 102	16.2 143	19.4 171	20 177	20 177	20 177	20 177	20 177	20 177	20 177
5IK60GE-SW2M / 5GE□SA	1.1 9.7	1.3 11.5	1.8 15.9	2.2 19.7	2.7 23	3.3 29	4.1 36	4.9 43	5.9 52	7.4 65	8.9 78	10.7 94	14.9 131	17.8 157	19.9 176	20 177	20 177	20 177	20 177	20 177	20 177

◇ 60 Hz

Unit = Upper values: N·m/Lower values: lb-in

Model Motor/ Gearhead	Speed r/min	600	500	360	300	240	200	144	120	100	72	60	50	36	30	24	20	18	15	12	10
		Gear Ratio	3	3.6	5	6	7.5	9	12.5	15	18	25	30	36	50	60	75	90	100	120	150
5RK60GE-AW2MU 5RK60GE-CW2ME / 5GE□SA	0.98 8.6	1.2 10.6	1.6 14.1	2.0 17.7	2.5 22	3.0 26	3.7 32	4.4 38	5.3 46	6.7 59	8.0 70	9.6 84	13.4 118	16.0 141	17.9 158	20 177	20 177	20 177	20 177	20 177	20 177
5IK60GE-SW2M / 5GE□SA	0.92 8.1	1.1 9.7	1.5 13.2	1.8 15.9	2.3 20	2.8 24	3.5 30	4.2 37	5.0 44	6.3 55	7.5 66	9.0 79	12.5 110	15.0 132	16.8 148	20 177	20 177	20 177	20 177	20 177	20 177

Gearmotor – Torque Table When Right-Angle Gearhead is Attached

→ Page C-238

Permissible Overhung Load and Permissible Thrust Load

Motor (Round shaft type) → Page C-17

Gearhead → Page C-17

Permissible Load Inertia J of Gearhead

→ Page C-18

Starting and Braking Characteristics (Reference values)

Single-Phase Motor

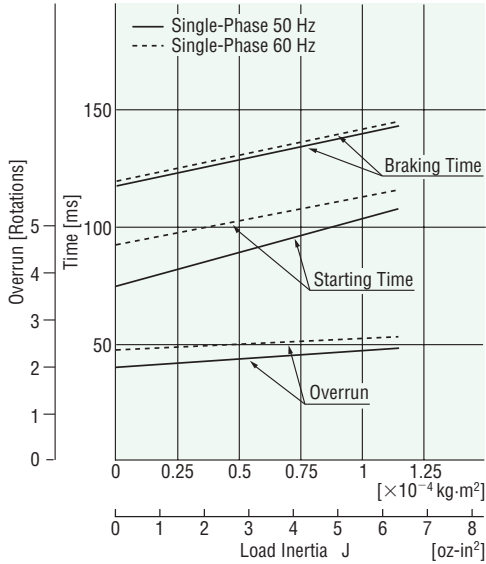

Three-Phase Motor

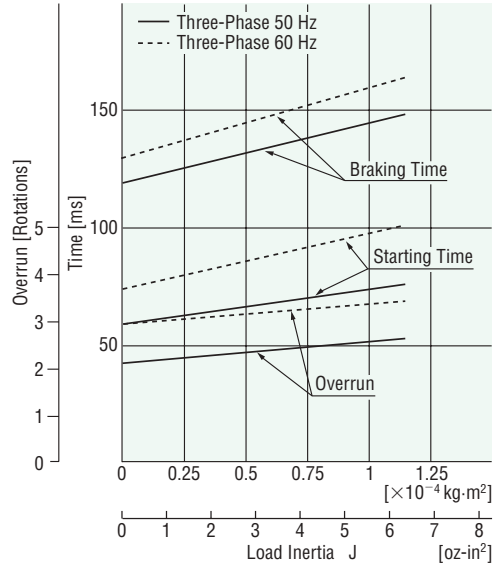

Dimensions Unit = mm (in.)

● Mounting screws are included with gearheads. Dimensions for mounting screws → Page C-280

Motor/Gearhead

Mass: Motor 3.4 kg (7.5 lb.)
Gearhead 1.5 kg (3.3 lb.)

DXF A470U

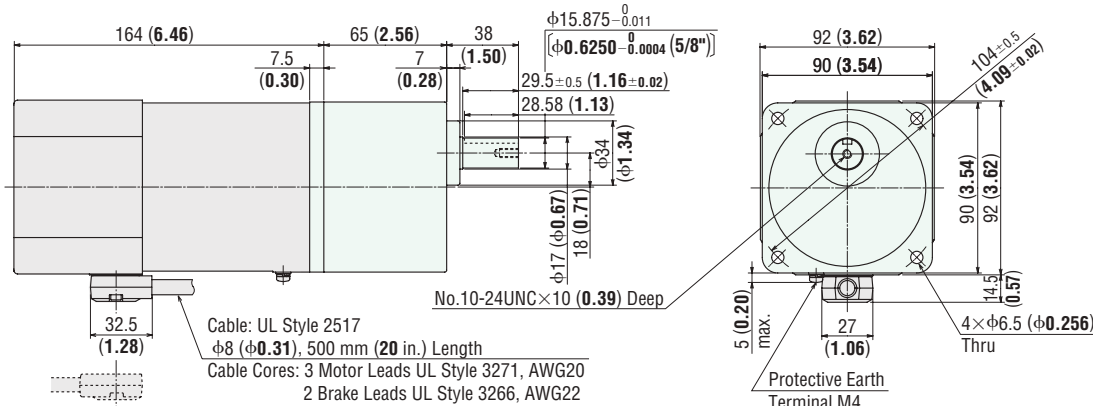

● Cable direction can be switched to the opposite direction.

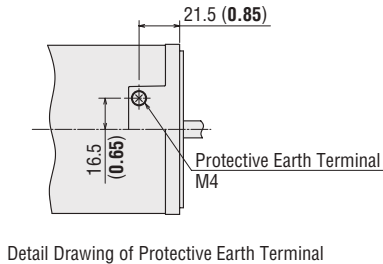

Key and Key Slot

(The key is included with the gearhead)

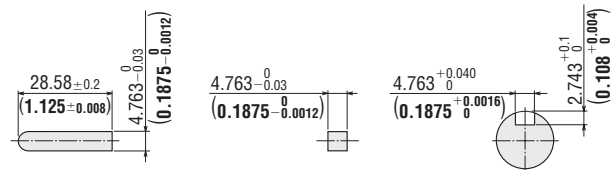

◇ Shaft Section of Round Shaft Type

The mass and motor's dimensions (excluding the shaft section) are the same as those of the pinion shaft types.

Mass: 3.4 kg (7.5 lb.)

DXF A471

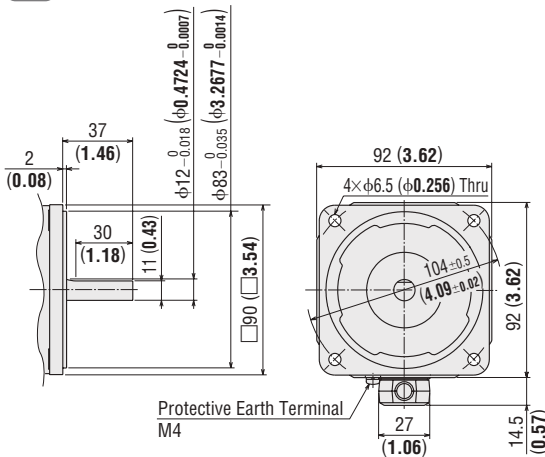

◇ Decimal Gearhead

Can be connected to **GE** pinion shaft type.

5GE10XS

Mass: 0.6 kg (1.32 lb.)

DXF A029

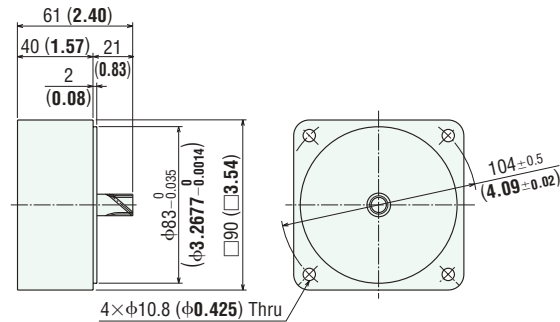

◇ Capacitor

(Included with single-phase motors)

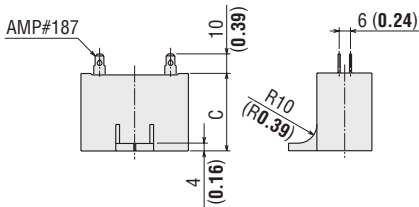
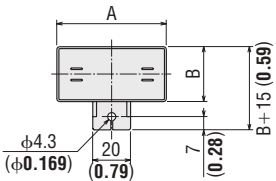

◇ Capacitor Dimensions Unit = mm (in.)

Model		Capacitor Model	A	B	C	Mass g (oz.)	Capacitor Cap
Pinion Shaft Type	Round Shaft Type						
5RK60GE-AW2MU	5RK60A-AW2MU	CH200CFAUL2	58 (2.28)	29 (1.14)	41 (1.61)	91 (3.2)	Included
5RK60GE-CW2ME	5RK60A-CW2ME	CH50BFAUL	58 (2.28)	29 (1.14)	41 (1.61)	93 (3.3)	

■ Connection Diagrams

→ Page C-114

Gearhead, Accessories and Peripheral Equipment

Space-Saving Right-Angle Gearheads
→ Page C-227



Instantaneous Stop Brake Pack
→ Page C-253



Accessories
→ Page C-263



Power Off Activated Type Electromagnetic Brake Motors

90 W (1/8 HP)

Frame Size: □90 mm (□3.54 in.)



(Gearhead sold separately)

Specifications

● Motor (RoHS)



Model		Rating	Output Power W HP	Voltage VAC	Frequency Hz	Current A	Starting Torque mN·m oz·in	Rated Torque mN·m oz·in	Rated Speed r/min	Capacitor μF
Pinion Shaft Type	Round Shaft Type									
TP 5RK90GE-AW2MU	5RK90A-AW2MU	30 minutes	90 1/8	Single-Phase 110	60	1.81	590 83	585 83	1500	30
				Single-Phase 115						
TP 5RK90GE-CW2ME	5RK90A-CW2ME	30 minutes	90 1/8	Single-Phase 220	60	0.96	590 83	605 85	1450	7.0
				Single-Phase 230						
				50	0.82	600 85	730 103	1200		
				60					0.96	
TP 5IK90GE-SW2M	5IK90A-SW2M	Continuous	90 1/8	Three-Phase 200	50	0.64	850 120	680 96		1300
					60				0.59	
				Three-Phase 220	60	0.60	700	570		1600
									Three-Phase 230	

- This type of motor does not contain a built-in friction brake mechanism similar to the reversible motors.
- The **U** and **E** at the end of the model name indicate that the unit includes a capacitor. These letters are not listed on the motor nameplate. When the motor is approved under various safety standards, the model name on the nameplate is the approved model name. → Page H-11
- Details of safety standards → Page H-2

TP: Contains a built-in thermal protector (automatic return type). If a motor overheats for any reason, the thermal protector is activated and the motor is stopped. (The power supply to the electromagnetic brake is kept and the brake is released.)
When the motor temperature drops, the thermal protector closes and the motor restarts. Be sure to turn the motor power off before inspecting.

● Electromagnetic Brake (Power Off Activated Type)

Motor Model	Voltage VAC	Frequency Hz	Current A	Input W	Holding Brake Torque mN·m oz·in	
5RK90GE-AW2MU 5RK90A-AW2MU	Single-Phase 110	60	0.13	10	500	
	Single-Phase 115				71	
5RK90GE-CW2ME 5RK90A-CW2ME	Single-Phase 220	60	0.07	10	500	
	Single-Phase 230				50	71
					60	
5IK90GE-SW2M 5IK90A-SW2M	Single-Phase 200	50	0.07	10	500	
		60				
	Single-Phase 220	60				71

High Strength, Long Life, Low Noise
V Series

Highest Maximum Permissible torque, 10,000 hours of life and quiet operation. For more details on V Series see page C-149 or visit www.orientalmotor.com.



Product Line

Motor (RoHS)

Model	
Pinion Shaft Type	Round Shaft Type
5RK90GE-AW2MU	5RK90A-AW2MU
5RK90GE-CW2ME	5RK90A-CW2ME
5IK90GE-SW2M	5IK90A-SW2M

The following items are included in each product.
 Motor, Capacitor*, Capacitor Cap*, Operating Manual
 *Only for single-phase motors

Parallel Shaft Gearhead/Right-Angle Gearhead (Sold separately) (RoHS)

Gearhead Type		Gearhead Model	Gear Ratio
Parallel Shaft	Long Life GE-S Gearhead	5GE□SA	3, 3.6, 5, 6, 7.5, 9, 12.5, 15, 18, 25, 30, 36, 50, 60, 75, 90, 100, 120, 150, 180
	Hollow Shaft	5GE□RH	
Right-Angle Shaft	Solid Shaft	5GE□RAA	
Parallel Shaft	Long Life GE-S Gearhead	5GE10XS (Decimal Gearhead)	

Enter the gear ratio in the box (□) within the model name.

The following items are included in each product.

- Parallel Shaft Gearhead
Gearhead, Mounting Screws, Parallel Key, Operating Manual
- Hollow Shaft Gearhead
Gearhead, Mounting Screws, Parallel Key, Safety Cover (with screws), Gasket, Operating Manual
- Solid Shaft Gearhead
Gearhead, Mounting Screws, Parallel Key, Gasket, Operating Manual

Gearmotor – Torque Table

- Enter the gear ratio in the box (□) within the gearhead model name.
- A colored background (□) indicates gear shaft rotation in the same direction as the motor shaft, while the others rotate in the opposite direction.
- The speed is calculated by dividing the motor's synchronous speed (50 Hz: 1500 r/min, 60 Hz: 1800 r/min) by the gear ratio.
The actual speed is 2~20% less than the displayed value, depending on the load.
- To reduce the speed beyond the gear ratio in the table, attach a decimal gearhead (gear ratio 10:1) between the gearhead and the motor.
In that case, the permissible torque is 20 N·m (177 lb-in).

◇ 50 Hz

Unit = Upper values: N·m/Lower values: lb-in

Model Motor/ Gearhead	Speed r/min	500	417	300	250	200	167	120	100	83	60	50	42	30	25	20	17	15	12.5	10	8.3
	Gear Ratio	3	3.6	5	6	7.5	9	12.5	15	18	25	30	36	50	60	75	90	100	120	150	180
5RK90GE-CW2ME / 5GE□SA	1.8 15.9	2.1 18.5	3.0 26	3.5 30	4.4 38	5.3 46	6.7 59	8.0 70	9.6 84	12.0 106	14.5 128	17.3 153	20 177	20 177	20 177	20 177	20 177	20 177	20 177	20 177	20 177
5IK90GE-SW2M / 5GE□SA	1.7 15.0	2.0 17.7	2.8 24	3.3 29	4.1 36	5.0 44	6.2 54	7.4 65	8.9 78	11.2 99	13.5 119	16.2 143	20 177	20 177	20 177	20 177	20 177	20 177	20 177	20 177	20 177

◇ 60 Hz

Unit = Upper values: N·m/Lower values: lb-in

Model Motor/ Gearhead	Speed r/min	600	500	360	300	240	200	144	120	100	72	60	50	36	30	24	20	18	15	12	10
	Gear Ratio	3	3.6	5	6	7.5	9	12.5	15	18	25	30	36	50	60	75	90	100	120	150	180
5RK90GE-AW2MU / 5GE□SA	1.4 12.3	1.7 15.0	2.4 21	2.8 24	3.6 31	4.3 38	5.3 46	6.4 56	7.7 68	9.7 85	11.6 102	13.9 123	19.3 170	20 177	20 177	20 177	20 177	20 177	20 177	20 177	20 177
5RK90GE-CW2ME / 5GE□SA	1.5 13.2	1.8 15.9	2.5 22	2.9 25	3.7 32	4.4 38	5.5 48	6.6 58	7.9 69	10.0 88	12.0 106	14.4 127	20 177	20 177	20 177	20 177	20 177	20 177	20 177	20 177	20 177
5IK90GE-SW2M / 5GE□SA	1.4 12.3	1.7 15.0	2.3 20	2.8 24	3.5 30	4.2 37	5.2 46	6.2 54	7.5 66	9.4 83	11.3 100	13.5 119	18.8 166	20 177	20 177	20 177	20 177	20 177	20 177	20 177	20 177

Gearmotor – Torque Table When Right-Angle Gearhead is Attached

→ Page C-238

Permissible Overhung Load and Permissible Thrust Load

Motor (Round shaft type) → Page C-17

Gearhead → Page C-17

Permissible Load Inertia J of Gearhead

→ Page C-18

Starting and Braking Characteristics (Reference values)

Single-Phase Motor

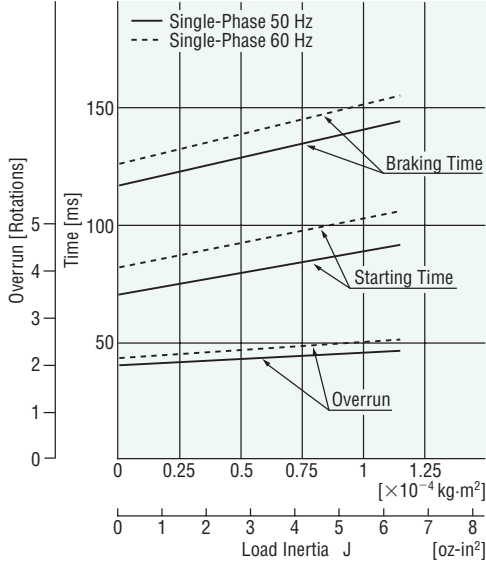

Three-Phase Motor

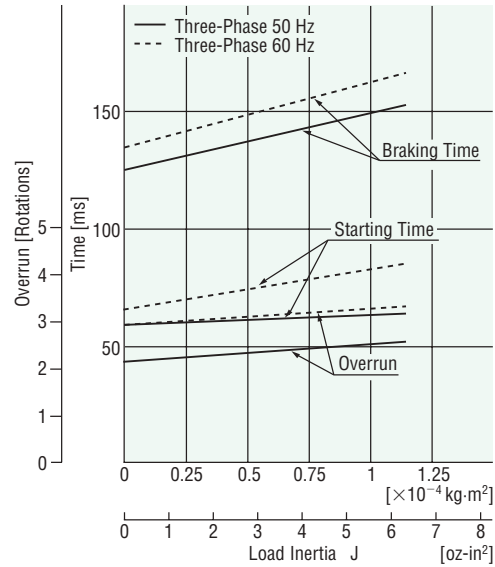

Dimensions Unit = mm (in.)

● Mounting screws are included with gearheads. Dimensions for mounting screws → Page C-280

Motor/Gearhead

Mass: Motor 3.9 kg (8.6 lb.)

Gearhead 1.5 kg (3.3 lb.)

DXF A472U

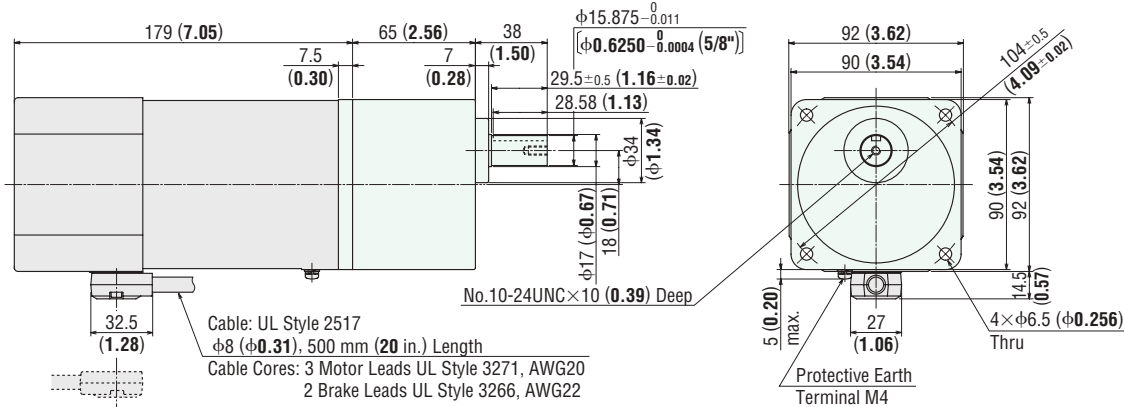

● Cable direction can be switched to the opposite direction.

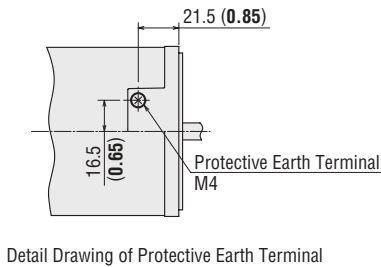

Key and Key Slot (The key is included with the gearhead)

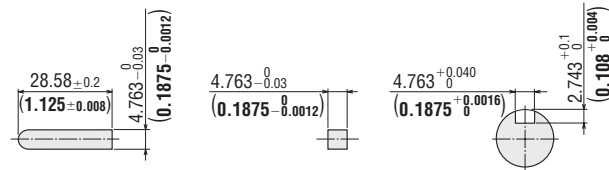

◇ Shaft Section of Round Shaft Type

The mass and motor's dimensions (excluding the shaft section) are the same as those of the pinion shaft types.

Mass: 3.9 kg (8.6 lb.)

DXF A473

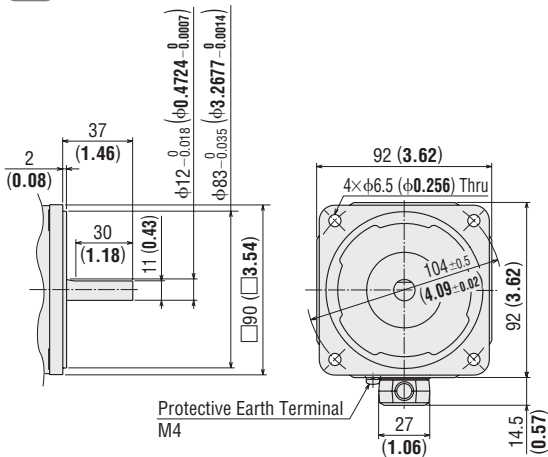

◇ Decimal Gearhead

Can be connected to **GE** pinion shaft type.

5GE10XS

Mass: 0.6 kg (1.32 lb.)

DXF A029

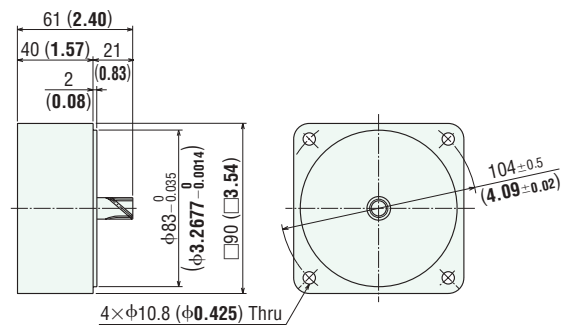

◇ Capacitor

(Included with single-phase motors)

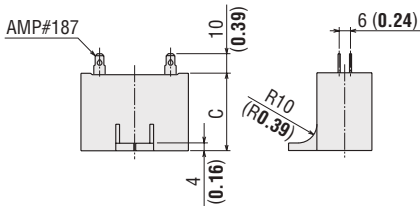
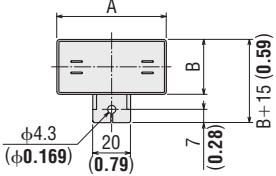

◇ Capacitor Dimensions Unit = mm (in.)

Model		Capacitor Model	A	B	C	Mass g (oz.)	Capacitor Cap
Pinion Shaft Type	Round Shaft Type						
5RK90GE-AW2MU	5RK90A-AW2MU	CH300CFAUL2	58 (2.28)	35 (1.38)	50 (1.97)	140 (4.9)	Included
5RK90GE-CW2ME	5RK90A-CW2ME	CH70BFAUL	58 (2.28)	35 (1.38)	50 (1.97)	138 (4.9)	

■ Connection Diagrams

→ Page C-114

Gearhead, Accessories and Peripheral Equipment

Space-Saving Right-Angle Gearheads
→ Page C-227



Instantaneous Stop Brake Pack
→ Page C-253



Accessories
→ Page C-263



Induction Motors BH Series

Power Off Activated Electromagnetic Brake

200 W (1/4 HP)

Frame Size: □104 mm (□4.09 in.)



Right-Angle Hollow Shaft



Parallel Shaft

Features

- **High Power 200 W (1/4 HP)**
Smallest frame size among 200 W (1/4 HP) motors
- **Hypoid Gear Right-Angle Gearheads**
Right-angle gearheads employ hypoid gears. Hollow shafts and solid shafts are available to enable space-saving.
- **Tapped Hole at the Shaft End**
The gearhead shafts feature a tapped hole for convenient connection with a load.

● "Combination Type" for Easy Installation

The combination type comes with the motor and gearhead pre-assembled. This enables easy installation in equipment.

Combination Type:
The combination type comes with the motor and its dedicated gearhead pre-assembled which simplifies installation in equipment. Motors and gearheads are also available separately to facilitate changes or repairs.

Specifications – Continuous Rating (RoHS)



Model		Output Power	Voltage	Frequency	Current	Starting Torque	Rated Torque	Rated Speed	Capacitor
Combination Type	Round Shaft Type	W HP	VAC	Hz	A	N-m oz-in	N-m oz-in	r/min	μF
(TP) BHI62FMT-□RH BHI62FMT-□RA BHI62FMT-□	BHI62FMT-A	200 1/4	Single-Phase 110	60	3	0.88	1.27	1500	40
			Single-Phase 115			124			
(TP) BHI62EMT-□RH BHI62EMT-□RA BHI62EMT-□	BHI62EMT-A	200 1/4	Single-Phase 220	50	1.5	0.98	1.52	1250	10
				60			210	1500	
			Single-Phase 230	50			1.52	1250	
				60			210	1500	
(TP) BHI62SMT-□RH BHI62SMT-□RA BHI62SMT-□	BHI62SMT-A	200 1/4	Three-Phase 200	50	1.1	1.49	1.49	1250	-
				60		210	1500		
			Three-Phase 220	60	0.95	1.23	1.23	1550	
				60		174	174		
			Three-Phase 230	60	1.18	1.18	1600		
					167	167			

- The values for each specification applies to the motor only.
- Details of safety standards → Page H-2
- For detailed product safety standard information including standards, file number and certification body, please visit www.orientalmotor.com.
- (TP): Contains a built-in thermal protector (automatic return type). If a motor overheats for any reason, the thermal protector is activated and the motor is stopped. (The power supply to the electromagnetic brake is kept and the brake is released.)
When the motor temperature drops, the thermal protector closes and the motor restarts. Be sure to turn the motor power off before inspecting.

● Electromagnetic Brake (Power Off Activated Type)

Motor Model	Voltage	Frequency	Current	Input	Holding Brake Torque
	VAC	Hz	A	W	N-m oz-in
BHI62FMT-□RH, BHI62FMT-□RA BHI62FMT-□, BHI62FMT-A	Single-Phase 110	60	0.17	12	1.5
	Single-Phase 115				210
BHI62EMT-□RH, BHI62EMT-□RA BHI62EMT-□, BHI62EMT-A	Single-Phase 220	50	0.09	12	1.5
		60			210
	Single-Phase 230	50	0.09	12	1.5
		60			210
BHI62SMT-□RH, BHI62SMT-□RA BHI62SMT-□, BHI62SMT-A	Single-Phase 200	50	0.09	12	1.5
		60			210
	Single-Phase 220	60	0.09	12	1.5
		60			210
	Single-Phase 230	60	0.09	12	1.5
		60			210

● Enter the gear ratio in the box (□) within the model name.

Product Line

● Combination Type (RoHS)

◇ Right-Angle Shaft

Type	Voltage	Model	Gear Ratio
Hollow Shaft	Single-Phase 110/115 VAC	BHI62FMT-□RH	5, 6, 7.5, 9, 12.5, 15, 18, 25, 30, 36, 50, 60, 75, 90, 100, 120, 150, 180
	Single-Phase 220/230 VAC	BHI62EMT-□RH	
	Three-Phase 200/220/230 VAC	BHI62SMT-□RH	
Solid Shaft	Single-Phase 110/115 VAC	BHI62FMT-□RA	
	Single-Phase 220/230 VAC	BHI62EMT-□RA	
	Three-Phase 200/220/230 VAC	BHI62SMT-□RA	

The following items are included in each product.
 Motor, Gearhead, Capacitor*, Capacitor Cap*, Parallel Key, Operating Manual
 * Only for single-phase motors

◇ Parallel Shaft

Voltage	Model	Gear Ratio
Single-Phase 110/115 VAC	BHI62FMT-□	3, 3.6, 5, 6, 7.5, 9, 12.5, 15, 18, 25, 30, 36, 50, 60, 75, 90, 100, 120, 150, 180
Single-Phase 220/230 VAC	BHI62EMT-□	
Three-Phase 200/220/230 VAC	BHI62SMT-□	

The following items are included in each product.
 Motor, Gearhead, Capacitor*, Capacitor Cap*, Mounting Screws, Parallel Key,
 Operating Manual
 * Only for single-phase motors

● Enter the gear ratio in the box (□) within the model name.

Gearmotor – Torque Table for Combination Type

- Enter the gear ratio in the box (□) within the model name.
- A colored background (□) indicates gear shaft rotation in the same direction as the motor shaft, while the others rotate in the opposite direction. The directions will be reversed for all right-angle shaft types.
- The speed is calculated by dividing the motor's synchronous speed (50 Hz: 1500 r/min, 60 Hz: 1800 r/min) by the gear ratio.
 The actual speed is 2~20% less than the displayed value, depending on the load.
- Decimal gearheads are not available for the **BH** Series.

● Right-Angle Shaft 50 Hz

Unit = Upper values: N-m/Lower values: lb-in

Model	Speed r/min	300	250	200	167	120	100	83	60	50	42	30	25	20	17	15	12.5	10	8.3
	Gear Ratio	5	6	7.5	9	12.5	15	18	25	30	36	50	60	75	90	100	120	150	180
BHI62EMT-□RH/RA		5.5 48	6.7 59	8.3 73	10.0 88	13.9 123	16.6 146	20.0 177	27.7 240	33.3 290	36.0 310	40.0 350	43.0 380	47.0 410	51.5 450	54.5 480	60 530	60 530	60 530
BHI62SMT-□RH/RA		5.4 47	6.5 57	8.2 72	9.8 86	13.6 120	16.3 144	19.6 173	27.2 240	32.6 280	36.0 310	40.0 350	43.0 380	47.0 410	51.5 450	54.5 480	60 530	60 530	60 530

● Right-Angle Shaft 60 Hz

Unit = Upper values: N-m/Lower values: lb-in

Model	Speed r/min	360	300	240	200	144	120	100	72	60	50	36	30	24	20	18	15	12	10
	Gear Ratio	5	6	7.5	9	12.5	15	18	25	30	36	50	60	75	90	100	120	150	180
BHI62FMT-□RH/RA BHI62EMT-□RH/RA		4.6 40	5.6 49	7.0 61	8.3 73	11.6 102	13.9 123	16.7 147	23.2 200	27.8 240	33.4 290	40.0 350	43.0 380	47.0 410	51.5 450	54.5 480	60 530	60 530	60 530
BHI62SMT-□RH/RA (200 VAC)		4.6 40	5.5 48	6.8 60	8.2 72	11.4 100	13.7 121	16.4 145	22.8 200	27.4 240	32.9 290	40.0 350	43.0 380	47.0 410	51.5 450	54.5 480	60 530	60 530	60 530
BHI62SMT-□RH/RA (220 VAC)		4.5 39	5.4 47	6.7 59	8.1 71	11.2 99	13.5 119	16.2 143	22.4 198	26.9 230	32.3 280	40.0 350	43.0 380	47.0 410	51.5 450	54.5 480	60 530	60 530	60 530
BHI62SMT-□RH/RA (230 VAC)		4.3 38	5.2 46	6.5 57	7.8 69	10.8 95	12.9 114	15.5 137	21.5 190	25.8 220	31.0 270	40.0 350	43.0 380	47.0 410	51.5 450	54.5 480	60 530	60 530	60 530

● Round Shaft Type (RoHS)

Voltage	Model
Single-Phase 110/115 VAC	BHI62FMT-A
Single-Phase 220/230 VAC	BHI62EMT-A
Three-Phase 200/220/230 VAC	BHI62SMT-A

The following items are included in each product.
 Motor, Capacitor*, Capacitor Cap*, Operating Manual
 * Only for single-phase motors

● Parallel Shaft 50 Hz

Unit = Upper values: N-m/Lower values: lb-in

Model	Speed r/min	500	417	300	250	200	167	120	100	83	60	50	42	30	25	20	17	15	12.5	10	8.3
	Gear Ratio	3	3.6	5	6	7.5	9	12.5	15	18	25	30	36	50	60	75	90	100	120	150	180
BHI62EMT-□		4.1 36	4.9 43	6.8 60	8.2 72	10.3 91	12.3 108	16.3 144	19.6 173	23.5 200	32.7 280	39.2 340	40 350	40 350	40 350	40 350	40 350	40 350	40 350	40 350	40 350
BHI62SMT-□		4.0 35	4.8 42	6.7 59	8.0 70	10.1 89	12.1 107	16.0 141	19.2 169	23.1 200	32.0 280	38.4 330	40 350	40 350	40 350	40 350	40 350	40 350	40 350	40 350	40 350

● Parallel Shaft 60 Hz

Unit = Upper values: N-m/Lower values: lb-in

Model	Speed r/min	600	500	360	300	240	200	144	120	100	72	60	50	36	30	24	20	18	15	12	10
	Gear Ratio	3	3.6	5	6	7.5	9	12.5	15	18	25	30	36	50	60	75	90	100	120	150	180
BHI62FMT-□		3.4 30	4.1 36	5.7 50	6.9 61	8.6 76	10.3 91	13.7 121	16.4 145	19.7 174	27.3 240	32.8 290	39.3 340	40 350	40 350	40 350	40 350	40 350	40 350	40 350	40 350
BHI62EMT-□		3.4 30	4.1 36	5.6 49	6.8 60	8.4 74	10.1 89	13.4 118	16.1 142	19.4 171	26.9 230	32.3 280	38.7 340	40 350	40 350	40 350	40 350	40 350	40 350	40 350	40 350
BHI62SMT-□ (200 VAC)		3.4 30	4.1 36	5.6 49	6.8 60	8.4 74	10.1 89	13.4 118	16.1 142	19.4 171	26.9 230	32.3 280	38.7 340	40 350	40 350	40 350	40 350	40 350	40 350	40 350	40 350
BHI62SMT-□ (220 VAC)		3.3 29	4.0 35	5.5 48	6.6 58	8.3 73	10.0 88	13.2 116	15.9 140	19.0 168	26.4 230	31.7 280	38.1 330	40 350	40 350	40 350	40 350	40 350	40 350	40 350	40 350
BHI62SMT-□ (230 VAC)		3.2 28	3.8 33	5.3 46	6.4 56	8.0 70	9.6 84	12.7 112	15.2 134	18.3 161	25.4 220	30.4 260	36.5 320	40 350	40 350	40 350	40 350	40 350	40 350	40 350	40 350

■ Permissible Overhung Load and Permissible Thrust Load

Combination Type → Page C-17

Round Shaft Type → Page C-17

■ Permissible Load Inertia J of Gearhead

→ Page C-18

■ Starting and Braking Characteristics (Reference values)

● Single-Phase Motor

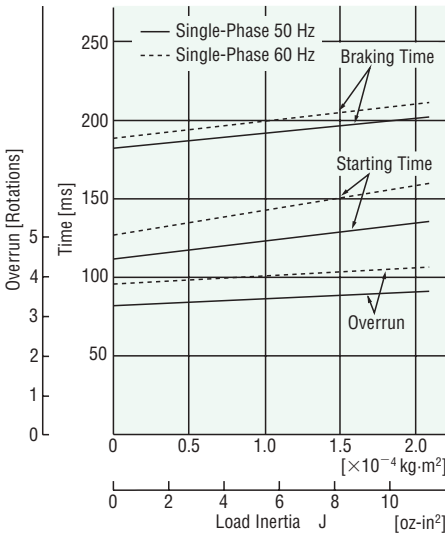

● Three-Phase Motor

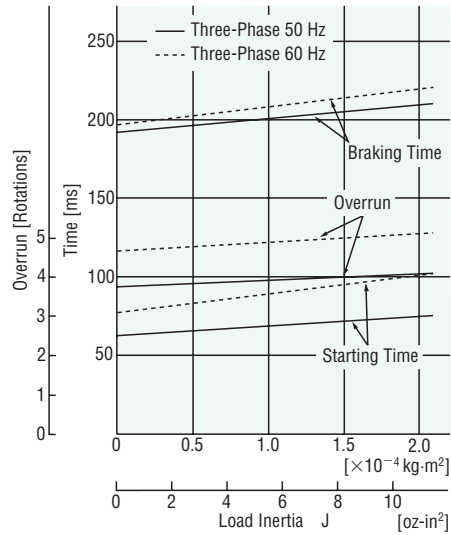

Dimensions Unit = mm (in.)

● Mounting screws are included with the combination type, parallel shaft. Dimensions for mounting screws → Page C-280

◇ Combination Type: Right-Angle, Hollow Shaft

BHI62FMT-□RH, BHI62EMT-□RH, BHI62SMT-□RH

Mass: 11.5 kg (25 lb.)

Motor: BHI62FMT-G2, BHI62EMT-G2, BHI62SMT-G2

Gearhead: BH6G2-□RH

DXF A384

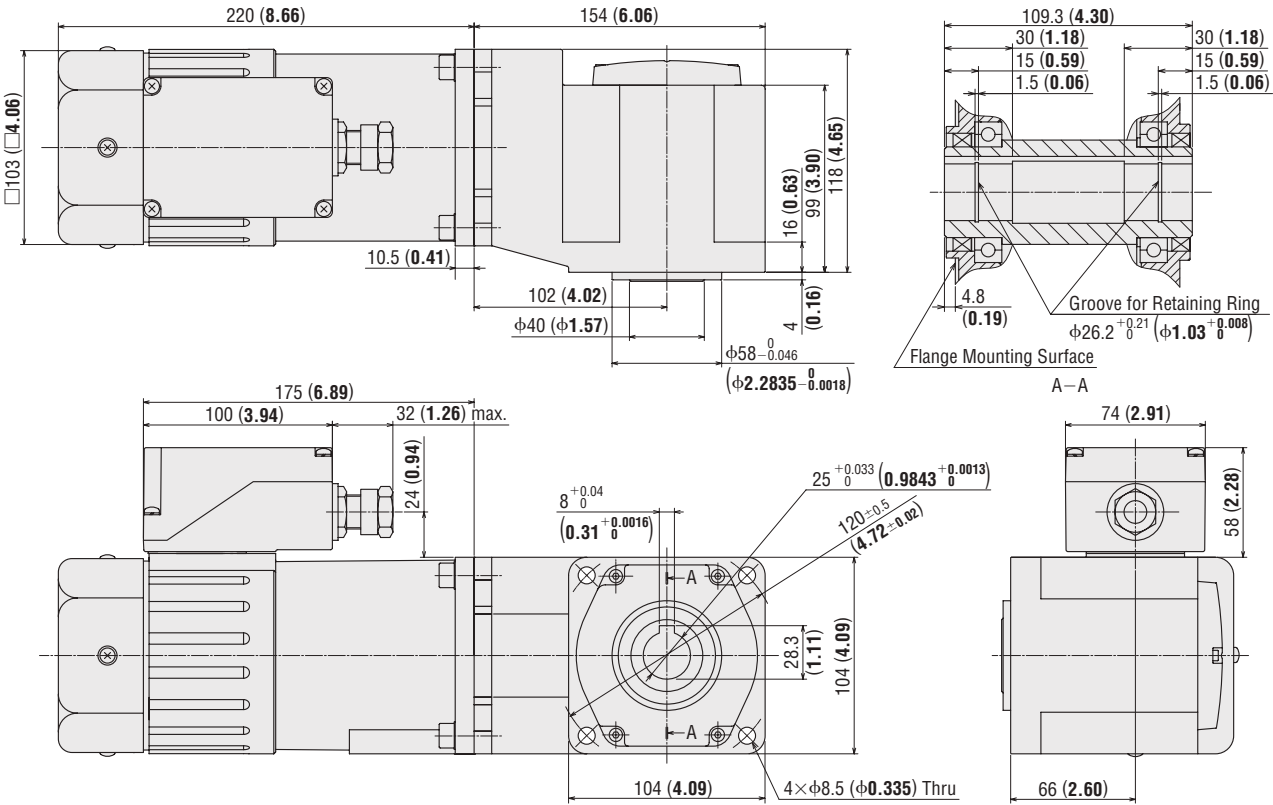

- Use cable with a diameter of $\phi 8 \sim \phi 12$ mm ($\phi 0.31 \sim \phi 0.47$ in.).
- Details of terminal box → Page C-283

◇ Key (Included)

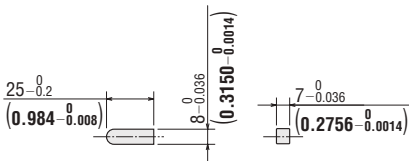

● Enter the gear ratio in the box (□) within the model name.

6 W (1/125 HP)
15 W (1/50 HP)
25 W (1/30 HP)
40 W (1/19 HP)
60 W (1/12 HP)
90 W (1/8 HP)
200 W (1/4 HP)

◇ Combination Type: Right-Angle, Solid Shaft

BHI62FMT-□RA, BHI62EMT-□RA, BHI62SMT-□RA

Mass: 11.5 kg (25 lb.)

Motor: BHI62FMT-G2, BHI62EMT-G2, BHI62SMT-G2

Gearhead: BH6G2-□RA

DXF A385

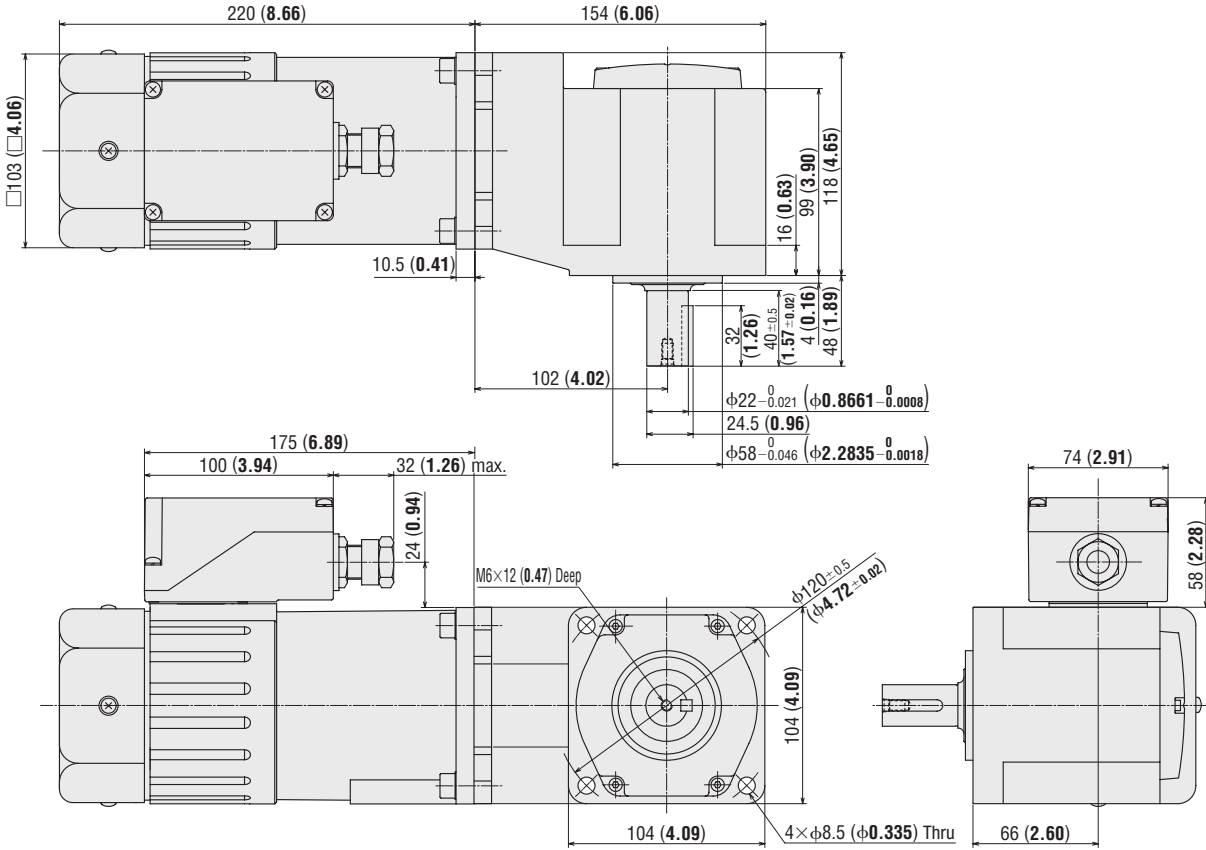

- Use cable with a diameter of φ8~φ12 mm (φ0.31~φ0.47 in.).
- Details of terminal box → Page C-283

◇ Key and Key Slot (Included)

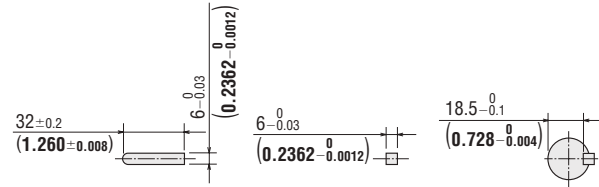

- At the shipment, a parallel key is inserted on the gearhead's shaft.

● Enter the gear ratio in the box (□) within the model name.

◇ Combination Type: Parallel Shaft

BHI62FMT-□, BHI62EMT-□, BHI62SMT-□

Mass: 9.5 kg (21 lb.)

Motor: BHI62FMT-G2, BHI62EMT-G2, BHI62SMT-G2

Gearhead: BH6G2-□

DXF A386

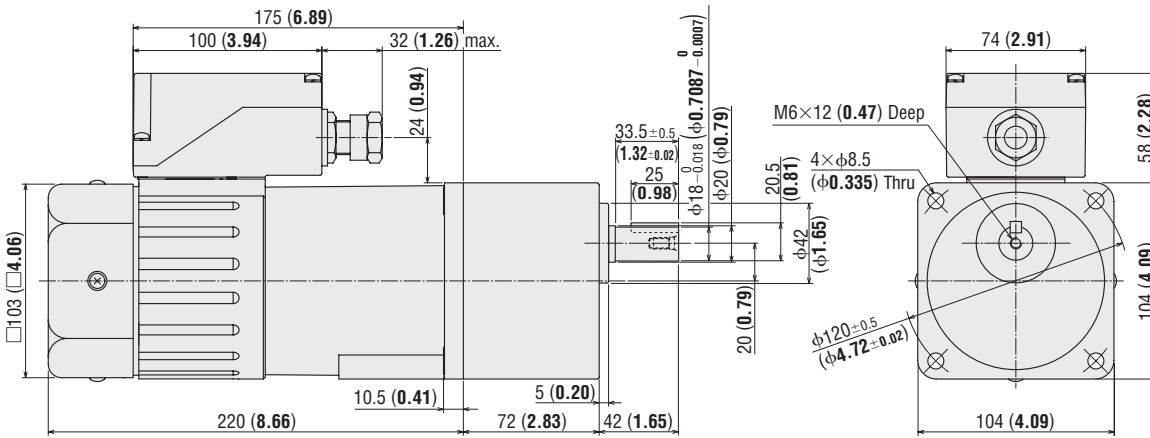

- Use cable with a diameter of $\phi 8 \sim \phi 12$ mm ($\phi 0.31 \sim \phi 0.47$ in.).
- Details of terminal box → Page C-283

◇ Key and Key Slot (Included)

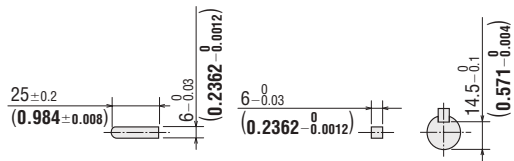

- At the shipment, a parallel key is inserted on the gearhead's shaft.

◇ Round Shaft Type

BHI62FMT-A, BHI62EMT-A, BHI62SMT-A

Mass: 6.5 kg (14 lb.)

DXF A387

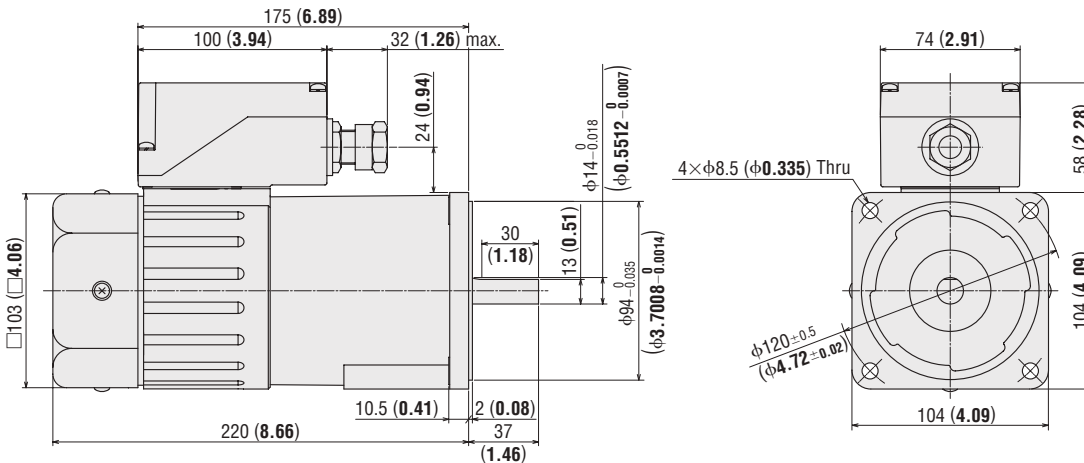

- Use cable with a diameter of $\phi 8 \sim \phi 12$ mm ($\phi 0.31 \sim \phi 0.47$ in.).
- Details of terminal box → Page C-283

- Enter the gear ratio in the box (□) within the model name.

6 W (1/125 HP)
 15 W (1/50 HP)
 25 W (1/30 HP)
 40 W (1/19 HP)
 60 W (1/12 HP)
 90 W (1/8 HP)
 200 W (1/4 HP)

◇ Capacitor (Included with single-phase motors)

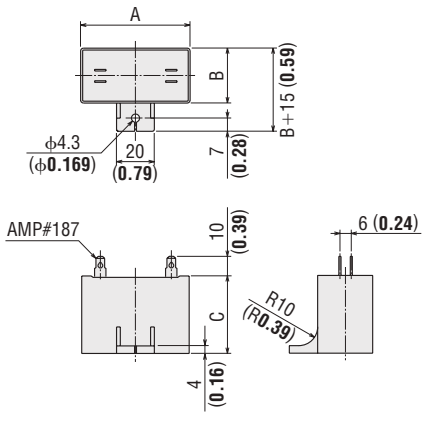

◇ Capacitor Dimensions Unit = mm (in.)

Model	Capacitor Model	A	B	C	Mass g (oz.)	Capacitor Cap
BHI62FMT-□RH BHI62FMT-□RA BHI62FMT-□ BHI62FMT-A	CH400CFAUL2	58 (2.28)	41 (1.61)	58 (2.28)	175 (6.2)	Included
BHI62EMT-□RH BHI62EMT-□RA BHI62EMT-□ BHI62EMT-A	CH100BFAUL	58 (2.28)	35 (1.38)	50 (1.97)	132 (4.7)	

● Enter the gear ratio in the box (□) within the model name.

■ Mounting Method for Right-Angle, Hollow Shaft Types

→ Page C-237

Connection Diagrams

- The direction of motor rotation is as viewed from the shaft end of the motor. CW indicates clockwise direction, while CCW counterclockwise direction.
- Enter the voltage (**F**, **E** or **S**) in the box (□) within the model name.

Motor Type	Single-Phase Motor	Three-Phase Motor
<ul style="list-style-type: none"> ● Combination Type: Parallel Shaft BHI62□MT-3~9 BHI62□MT-50~180 ● Round Shaft Type BHI62□MT-A 		<p>Clockwise</p>
<ul style="list-style-type: none"> ● Combination Type: Parallel Shaft BHI62□MT-12.5~36 ● Combination Type: Right Angle Shaft BHI62□MT-5~180RA BHI62□MT-5~180RH 		<p>Clockwise</p>
Rotation Direction	<p>Clockwise: To rotate in a clockwise (CW) direction, turn SW2 to CW.</p> <p>Counterclockwise: To rotate in a counterclockwise (CCW) direction, turn SW2 to CCW.</p>	To change the rotation direction, change any two connections between R, S and T.

PE: Protective Earth

SW1 operates both motor and electromagnetic brake action.

The electromagnetic brake will be released and the motor will rotate when SW1 is switched simultaneously to ON.

When SW1 is switched simultaneously to OFF, the motor stops immediately with the electromagnetic brake and holds the load.

Switch No.	Specifications			Note
	Single-Phase 110/115 VAC Input	Single-Phase 220/230 VAC Input	Three-Phase 200/220/230 VAC Input	
SW1	125 VAC 5 A minimum (Inductive Load)	250 VAC 5 A minimum (Inductive Load)	250 VAC 5 A minimum (Inductive Load)	Switched Simultaneously
SW2			-	-

Connect a CR circuit (R₀ C₀) for surge suppression shown on the diagrams to protect the contact.

R₀=5~200 Ω C₀=0.1~0.2 μF 200 WV

EPCR1201-2 (CR circuit) is available as an accessory.

Note

- Change the direction of single-phase motor rotation only after bringing the motor to a stop. If an attempt is made to change the direction of rotation while the motor is rotating, motor may ignore reversing command or change its direction of rotation after some delay.

- How to connect a capacitor → Page C-282

List of Motor and Gearhead Combinations

Motor and gearhead combinations are shown below.

● Combination Type: Right Angle Shaft

Model	Motor Model	Gearhead Model
BHI62FMT-□RH	BHI62FMT-G2	BH6G2-□RH
BHI62FMT-□RA		BH6G2-□RA
BHI62EMT-□RH	BHI62EMT-G2	BH6G2-□RH
BHI62EMT-□RA		BH6G2-□RA
BHI62SMT-□RH	BHI62SMT-G2	BH6G2-□RH
BHI62SMT-□RA		BH6G2-□RA

● Combination Type: Parallel Shaft

Model	Motor Model	Gearhead Model
BHI62FMT-□	BHI62FMT-G2	BH6G2-□
BHI62EMT-□	BHI62EMT-G2	
BHI62SMT-□	BHI62SMT-G2	

Accessories

Accessories

→ Page C-263



● Enter the gear ratio in the box (□) within the model name.