

High Power Induction Motors BH Series

200 W (1/4 HP)

Frame Size: □104 mm (□4.09 in.)

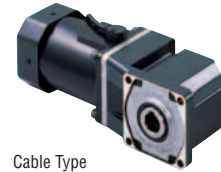

Cable Type
Right-Angle Hollow Shaft



Terminal Box Type
Parallel Shaft

Features

- **High Power 200 W (1/4 HP)**
Smallest frame size among 200 W (1/4 HP) motors
- **Hypoid Gear Right-Angle Gearheads**
Right-angle gearheads employ hypoid gears. Hollow shafts and solid shafts are available to enable space-saving.
- **Tapped Hole at the Shaft End**
The gearhead shafts feature a tapped hole for convenient connection with loads.

- **"Combination Type" for Easy Installation**
The combination type comes with the motor and gearhead pre-assembled. This enables easy installation in equipment.

Combination Type:
The combination type comes with the motor and its dedicated gearhead pre-assembled which simplifies installation in equipment. Motors and gearheads are also available separately to facilitate changes or repairs.

Specifications – Continuous Rating (RoHS)



Model Combination Type () : Round Shaft Type		Output Power W HP	Voltage VAC	Frequency Hz	Current A	Starting Torque N·m oz·in	Rated Torque N·m oz·in	Rated Speed r/min	Capacitor μF
Cable Type	Terminal Box Type								
ⓉP	BHI62F-□RH BHI62F-□RA BHI62F-□ (BHI62F-A)	200 1/4	Single-Phase 110	60	3	0.88	1.27	1500	40
						124			
ⓉP	BHI62ET-□RH BHI62ET-□RA BHI62ET-□ (BHI62ET-A)	200 1/4	Single-Phase 220	50	1.5	0.98 139	1.52 210	1250	10
				60			1.27 180	1500	
ⓉP	BHI62E-□RH BHI62E-□RA BHI62E-□ (BHI62E-A)	200 1/4	Single-Phase 230	50	1.1	1.49 210	1.52 210	1250	-
				60			1.25 177	1500	
ⓉP	BHI62S-□RH BHI62S-□RA BHI62S-□ (BHI62S-A)	200 1/4	Three-Phase 200	50	0.95	1.23 174	1.23 174	1550	-
				60			1.18 167	1600	

- Enter the gear ratio in the box (□) within the model name. The values for each specification applies to the motor only.
- Details of safety standards → Page H-2
- For detailed product safety standard information including standards, file number and certification body, please visit www.orientalmotor.com.
- ⓉP: Contains a built-in thermal protector (automatic return type). If a motor overheats for any reason, the thermal protector is activated and the motor is stopped. When the motor temperature drops, the thermal protector closes and the motor restarts. Be sure to turn the motor power off before inspecting.

Product Line

- **Combination Type (RoHS)**

◇ Right-Angle Shaft

Type	Voltage	Model	Gear Ratio
Hollow Shaft Cable	Single-Phase 110/115 VAC	BHI62F-□RH	5, 6, 7.5, 9, 12.5, 15, 18, 25, 30, 36, 50, 60, 75, 90, 100, 120, 150, 180
	Single-Phase 220/230 VAC	BHI62E-□RH	
	Three-Phase 200/220/230 VAC	BHI62S-□RH	
Hollow Shaft Terminal Box	Single-Phase 110/115 VAC	BHI62FT-□RH	
	Single-Phase 220/230 VAC	BHI62ET-□RH	
	Three-Phase 200/220/230 VAC	BHI62ST-□RH	
Solid Shaft Cable	Single-Phase 110/115 VAC	BHI62F-□RA	
	Single-Phase 220/230 VAC	BHI62E-□RA	
	Three-Phase 200/220/230 VAC	BHI62S-□RA	
Solid Shaft Terminal Box	Single-Phase 110/115 VAC	BHI62FT-□RA	
	Single-Phase 220/230 VAC	BHI62ET-□RA	
	Three-Phase 200/220/230 VAC	BHI62ST-□RA	

The following items are included in each product.
 Motor, Gearhead, Capacitor*, Capacitor Cap*, Parallel Key, Operating Manual
 * Only for single-phase motors

- Enter the gear ratio in the box (□) within the model name.

◇ Parallel Shaft

Type	Voltage	Model	Gear Ratio
Parallel Shaft Cable	Single-Phase 110/115 VAC	BHI62F -□	3, 3.6, 5, 6, 7.5, 9, 12.5, 15, 18, 25, 30, 36, 50, 60, 75, 90, 100, 120, 150, 180
	Single-Phase 220/230 VAC	BHI62E -□	
	Three-Phase 200/220/230 VAC	BHI62S -□	
Parallel Shaft Terminal Box	Single-Phase 110/115 VAC	BHI62FT -□	
	Single-Phase 220/230 VAC	BHI62ET -□	
	Three-Phase 200/220/230 VAC	BHI62ST -□	

● Enter the gear ratio in the box (□) within the model name.

The following items are included in each product.
 Motor, Gearhead, Capacitor*, Capacitor Cap*, Mounting Screws, Parallel Key, Operating Manual
 * Only for single-phase motors

● Round Shaft Type (RoHS)

Type	Voltage	Model
Cable	Single-Phase 110/115 VAC	BHI62F-A
	Single-Phase 220/230 VAC	BHI62E-A
	Three-Phase 200/220/230 VAC	BHI62S-A
Terminal Box	Single-Phase 110/115 VAC	BHI62FT-A
	Single-Phase 220/230 VAC	BHI62ET-A
	Three-Phase 200/220/230 VAC	BHI62ST-A

The following items are included in each product.

Motor, Capacitor*, Capacitor Cap*, Operating Manual
 * Only for single-phase motors

■ Gearmotor – Torque Table for Combination Type

- Enter the code that represents the terminal box type “T” in the box (□) within the model name.
- Enter the gear ratio in the box (□) within the model name.
- A colored background (□) indicates gear shaft rotation in the same direction as the motor shaft, while the others rotate in the opposite direction.
- The speed is calculated by dividing the motor's synchronous speed (50 Hz: 1500 r/min, 60 Hz: 1800 r/min) by the gear ratio. The actual speed is 2~20% less than the displayed value, depending on the load.
- Decimal gearheads are not available for the **BH** series.

● Right-Angle Shaft 50 Hz

Unit = Upper values: N-m/Lower values: lb-in

Model	Speed r/min	300	250	200	167	120	100	83	60	50	42	30	25	20	17	15	12.5	10	8.3
	Gear Ratio	5	6	7.5	9	12.5	15	18	25	30	36	50	60	75	90	100	120	150	180
BHI62E -□-□RH, BHI62E -□-□RA	5.5 48	6.7 59	8.3 73	10.0 88	13.9 123	16.6 146	20.0 177	27.7 240	33.3 290	36.0 310	40.0 350	43.0 380	47.0 410	51.5 450	54.5 480	60 530	60 530	60 530	60 530
BHI62S -□-□RH, BHI62S -□-□RA	5.4 47	6.5 57	8.2 72	9.8 86	13.6 120	16.3 144	19.6 173	27.2 240	32.6 280	36.0 310	40.0 350	43.0 380	47.0 410	51.5 450	54.5 480	60 530	60 530	60 530	60 530

● Right-Angle Shaft 60 Hz

Unit = Upper values: N-m/Lower values: lb-in

Model	Speed r/min	360	300	240	200	144	120	100	72	60	50	36	30	24	20	18	15	12	10
	Gear Ratio	5	6	7.5	9	12.5	15	18	25	30	36	50	60	75	90	100	120	150	180
BHI62F -□-□RH, BHI62F -□-□RA BHI62E -□-□RH, BHI62E -□-□RA	4.6 40	5.6 49	7.0 61	8.3 73	11.6 102	13.9 123	16.7 147	23.2 200	27.8 240	33.4 290	40.0 350	43.0 380	47.0 410	51.5 450	54.5 480	60 530	60 530	60 530	60 530
BHI62S -□-□RH, BHI62S -□-□RA (200 VAC)	4.6 40	5.5 48	6.8 60	8.2 72	11.4 100	13.7 121	16.4 145	22.8 200	27.4 240	32.9 290	40.0 350	43.0 380	47.0 410	51.5 450	54.5 480	60 530	60 530	60 530	60 530
BHI62S -□-□RH, BHI62S -□-□RA (220 VAC)	4.5 39	5.4 47	6.7 59	8.1 71	11.2 99	13.5 119	16.2 143	22.4 198	26.9 230	32.3 280	40.0 350	43.0 380	47.0 410	51.5 450	54.5 480	60 530	60 530	60 530	60 530
BHI62S -□-□RH, BHI62S -□-□RA (230 VAC)	4.3 38	5.2 46	6.5 57	7.8 69	10.8 95	12.9 114	15.5 137	21.5 190	25.8 220	31.0 270	40.0 350	43.0 380	47.0 410	51.5 450	54.5 480	60 530	60 530	60 530	60 530

● Parallel Shaft 50 Hz

Unit = Upper values: N-m/Lower values: lb-in

Model	Speed r/min	500	417	300	250	200	167	120	100	83	60	50	42	30	25	20	17	15	12.5	10	8.3	
	Gear Ratio	3	3.6	5	6	7.5	9	12.5	15	18	25	30	36	50	60	75	90	100	120	150	180	
BHI62E -□-□	4.1 36	4.9 43	6.8 60	8.2 72	10.3 91	12.3 108	16.3 144	19.6 173	23.5 200	32.7 280	39.2 340	40 350	40 350	40 350	40 350	40 350	40 350	40 350	40 350	40 350	40 350	40 350
BHI62S -□-□	4.0 35	4.8 42	6.7 59	8.0 70	10.1 89	12.1 107	16.0 141	19.2 169	23.1 200	32.0 280	38.4 330	40 350	40 350	40 350	40 350	40 350	40 350	40 350	40 350	40 350	40 350	40 350

● Parallel Shaft 60 Hz

Unit = Upper values: N-m/Lower values: lb-in

Model	Speed r/min	600	500	360	300	240	200	144	120	100	72	60	50	36	30	24	20	18	15	12	10	
	Gear Ratio	3	3.6	5	6	7.5	9	12.5	15	18	25	30	36	50	60	75	90	100	120	150	180	
BHI62F -□-□, BHI62E -□-□	3.4 30	4.1 36	5.7 50	6.9 61	8.6 76	10.3 91	13.7 121	16.4 145	19.7 174	27.3 240	32.8 290	38.3 340	40 350	40 350	40 350	40 350	40 350	40 350	40 350	40 350	40 350	40 350
BHI62S -□-□ (200 VAC)	3.4 30	4.1 36	5.6 49	6.8 60	8.4 74	10.1 89	13.4 118	16.1 142	19.4 171	26.9 230	32.3 280	38.7 340	40 350	40 350	40 350	40 350	40 350	40 350	40 350	40 350	40 350	40 350
BHI62S -□-□ (220 VAC)	3.3 29	4.0 35	5.5 48	6.6 58	8.3 73	10.0 88	13.2 116	15.9 140	19.0 168	26.4 230	31.7 280	38.1 330	40 350	40 350	40 350	40 350	40 350	40 350	40 350	40 350	40 350	40 350
BHI62S -□-□ (230 VAC)	3.2 28	3.8 33	5.3 46	6.4 56	8.0 70	9.6 84	12.7 112	15.2 134	18.3 161	25.4 220	30.4 260	36.5 320	40 350	40 350	40 350	40 350	40 350	40 350	40 350	40 350	40 350	40 350

Permissible Overhung Load and Permissible Thrust Load

Combination Type → Page C-17

Round Shaft Type → Page C-17

Permissible Load Inertia J of Gearhead

→ Page C-18

Dimensions Unit = mm (in.)

● Mounting screws are included with the combination type, parallel shaft. Dimensions for mounting screws → Page C-280

◇ Combination Type: Right-Angle, Hollow Shaft (Cable Type)

BHI62F-□RH, BHI62E-□RH, BHI62S-□RH

Mass: 10.0 kg (22 lb.)

Motor: BHI62F-G2, BHI62E-G2, BHI62S-G2

Gearhead: BH6G2-□RH

DXF A299

◇ Key (Included)

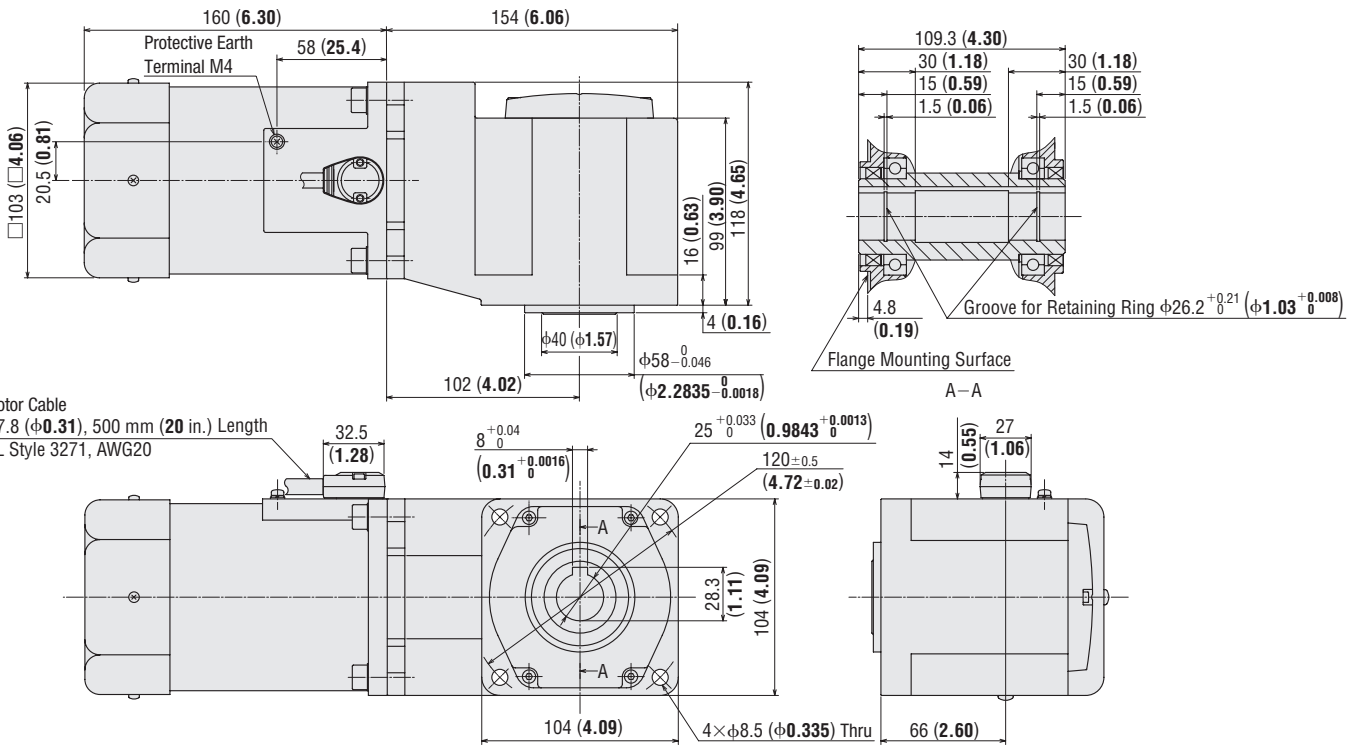
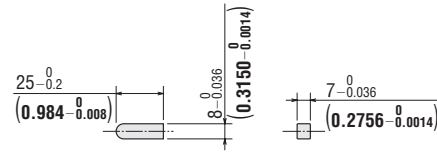

● Enter the gear ratio in the box (□) within the model name.

◇ Combination Type: Right-Angle, Solid Shaft (Cable Type)

BHI62F-□RA, BHI62E-□RA, BHI62S-□RA

Mass: 10.0 kg (22 lb.)

Motor: BHI62F-G2, BHI62E-G2, BHI62S-G2

Gearhead: BH6G2-□RA

DXF A300

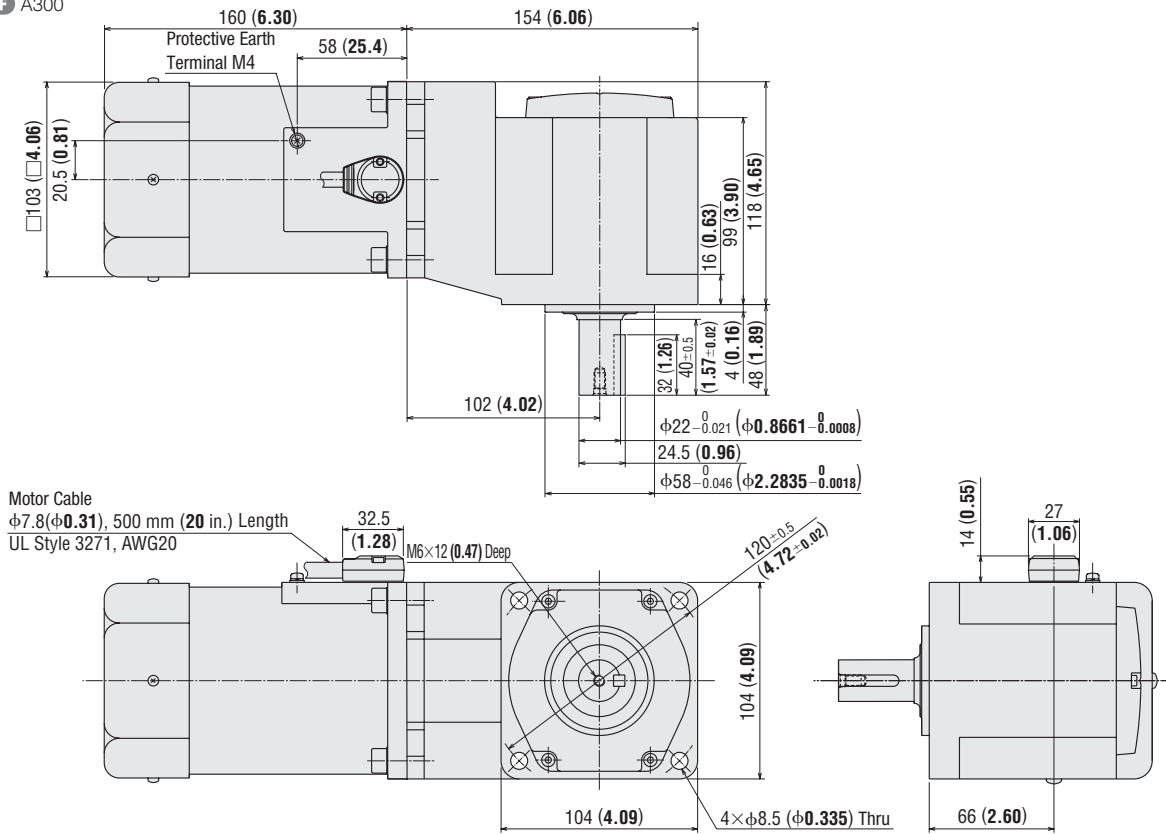

◇ Key and Key Slot (Included)

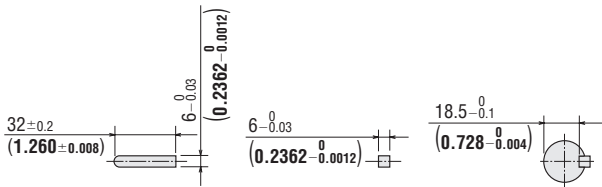

- At the time of shipment, a key is inserted on the gearhead's shaft.

● Enter the gear ratio in the box (□) within the model name.

◇ Combination Type: Right-Angle, Hollow Shaft (Terminal Box Type)

BHI62FT-□RH, BHI62ET-□RH, BHI62ST-□RH

Mass: 10.0 kg (22 lb.)

Motor: BHI62FT-G2, BHI62ET-G2, BHI62ST-G2

Gearhead: BH6G2-□RH

DXF A301

◇ Key (Included)

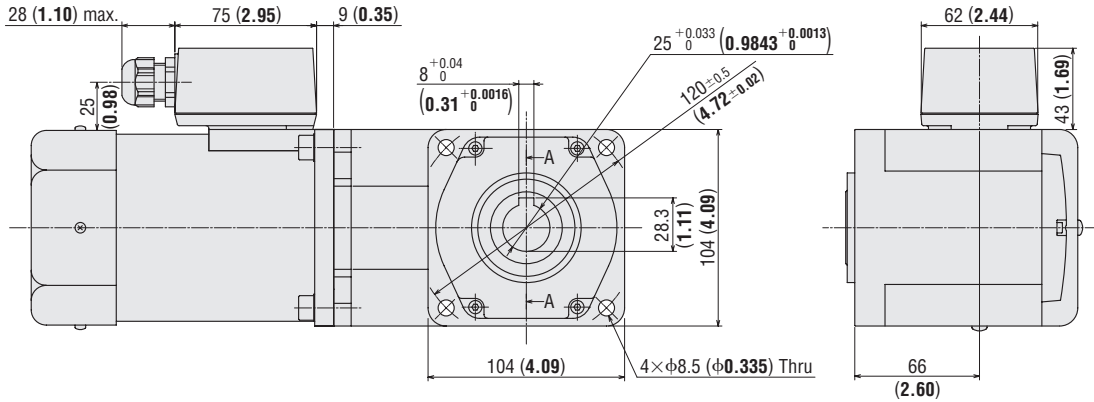
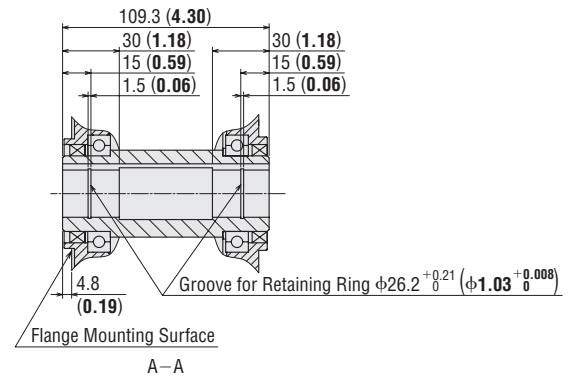
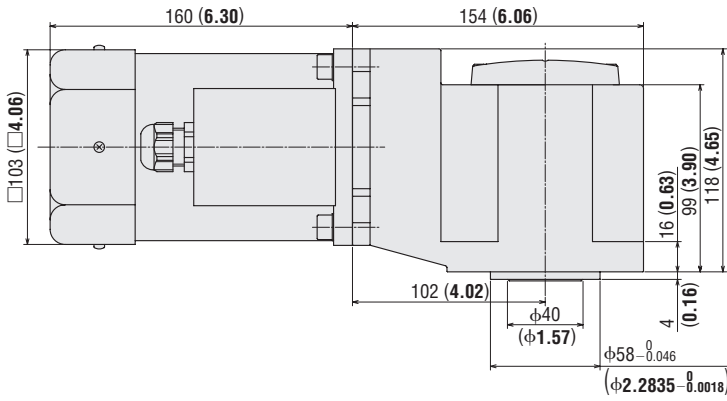
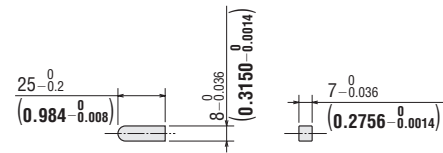

- Use cable with a diameter of $\phi 6 \sim \phi 12$ mm ($\phi 0.24 \sim \phi 0.47$ in.).
- Details of terminal box → Page C-283

● Enter the gear ratio in the box (□) within the model name.

◇ Combination Type: Right-Angle, Solid Shaft (Terminal Box Type)

BHI62FT-□RA, BHI62ET-□RA, BHI62ST-□RA

Mass: 10.0 kg (22 lb.)

Motor: BHI62FT-G2, BHI62ET-G2, BHI62ST-G2

Gearhead: BH6G2-□RA

DXF A302

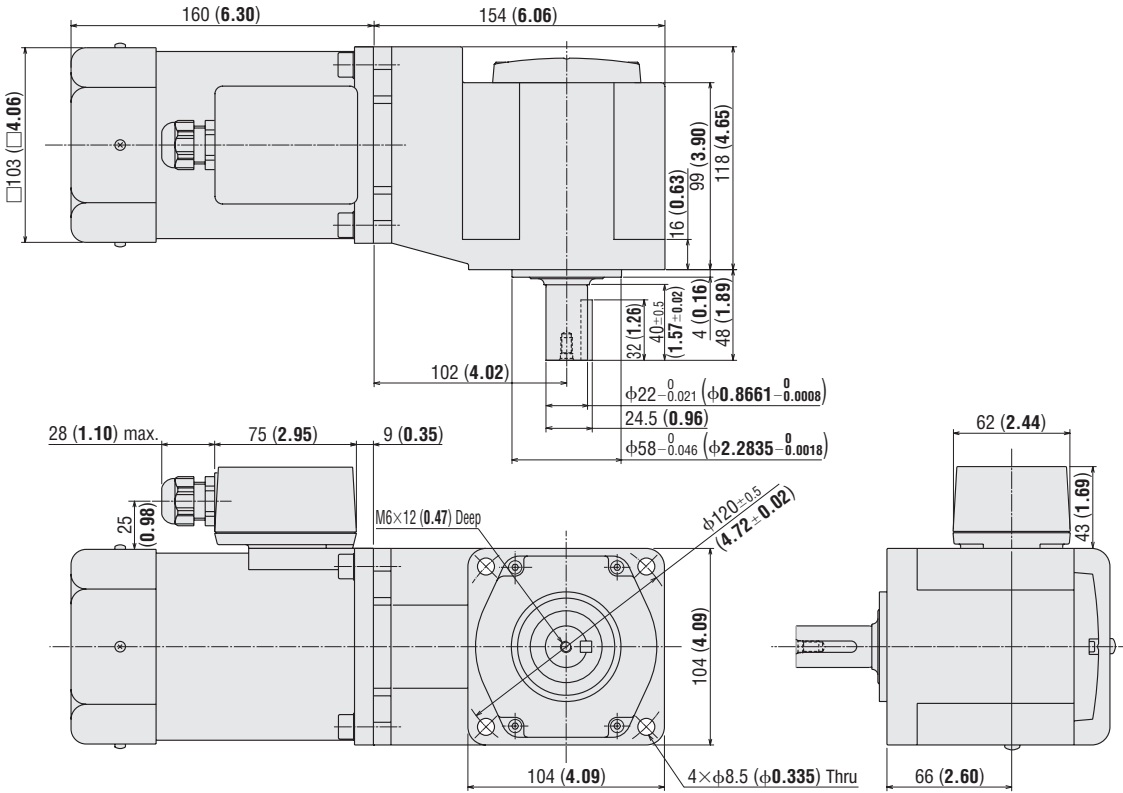

- Use cable with a diameter of $\phi 6 \sim \phi 12$ mm ($\phi 0.24 \sim \phi 0.47$ in.).
- Details of terminal box → Page C-283

◇ Key and Key Slot (Included)

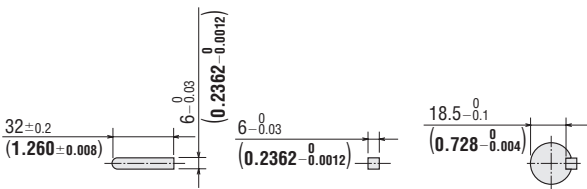

- At the time of shipment, a key is inserted on the gearhead's shaft.

- Enter the gear ratio in the box (□) within the model name.

- 1 W (1/750 HP)
- 3 W (1/125 HP)
- 6 W (1/125 HP)
- 15 W (1/50 HP)
- 25 W (1/30 HP)
- 40 W (1/19 HP)
- 60 W (1/12 HP)
- 90 W (1/8 HP)
- 200 W (1/4 HP)
- 2-Pole
40-150 W (1/19-1/5 HP)

◇ Combination Type: Parallel Shaft (Cable Type)

BHI62F-□, BHI62E-□, BHI62S-□

Mass: 8.0 kg (18 lb.)

Motor: BHI62F-G2, BHI62E-G2, BHI62S-G2

Gearhead: BH6G2-□

DXF A303

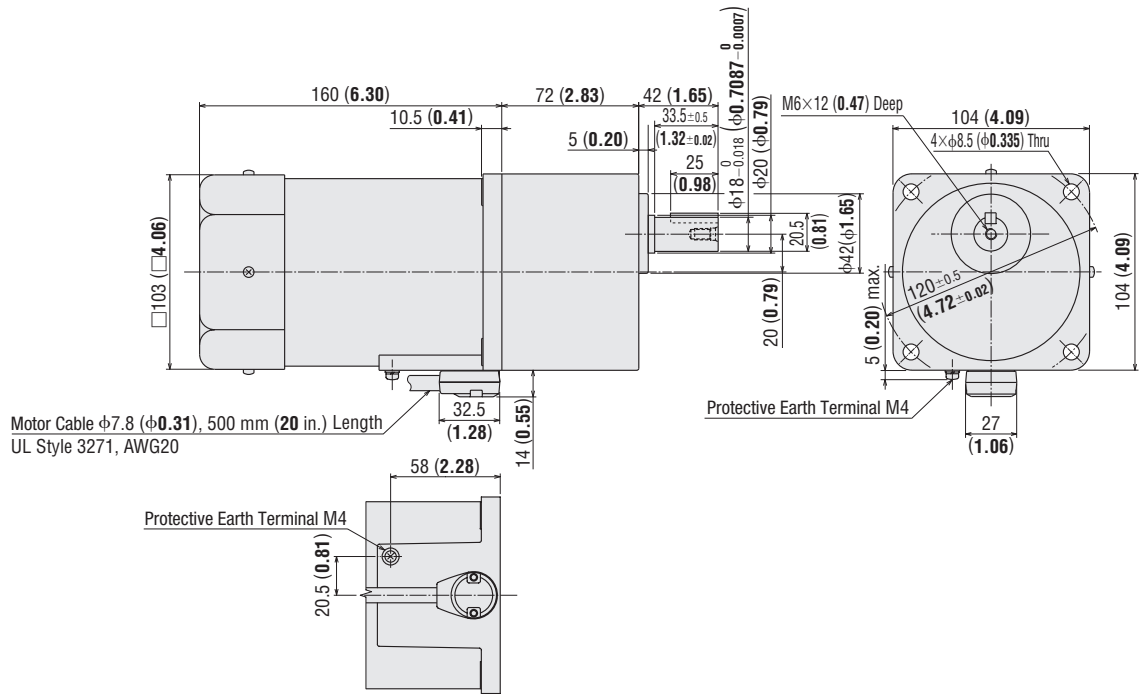

◇ Combination Type: Parallel Shaft (Terminal Box Type)

BHI62FT-□, BHI62ET-□, BHI62ST-□

Mass: 8.0 kg (18 lb.)

Motor: BHI62FT-G2, BHI62ET-G2, BHI62ST-G2

Gearhead: BH6G2-□

DXF A304

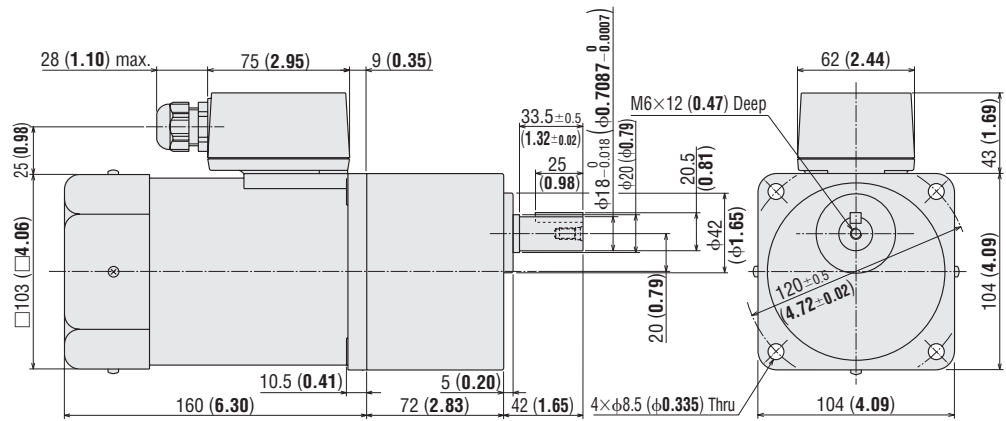

- Use cable with a diameter of $\phi 6 \sim \phi 12$ mm ($\phi 0.24 \sim \phi 0.47$ in.).
- Details of terminal box → Page C-283

◇ Key and Key Slot (Included)

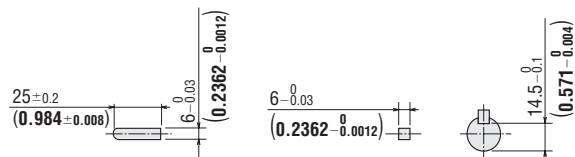

- At the time of shipment, a key is inserted on the gearhead's shaft.

- Enter the gear ratio in the box (□) within the model name.

◇ Round Shaft Type (Cable Type)

BHI62F-A, BHI62E-A, BHI62S-A

Mass: 5.0 kg (11 lb.)

DXF A307

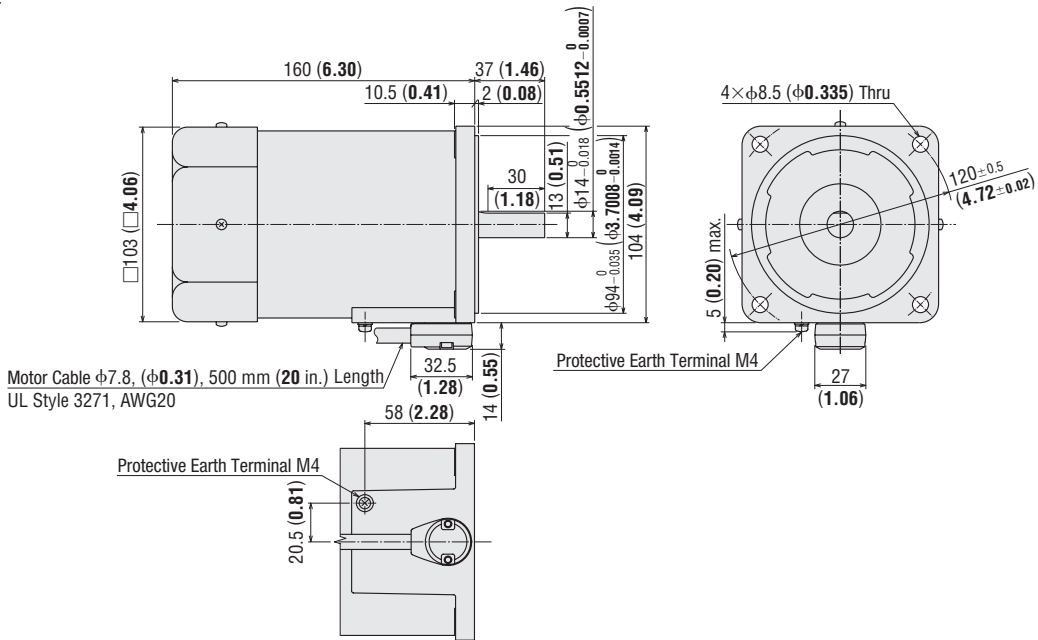

◇ Round Shaft Type (Terminal Box Type)

BHI62FT-A, BHI62ET-A, BHI62ST-A

Mass: 5.0 kg (11 lb.)

DXF A308

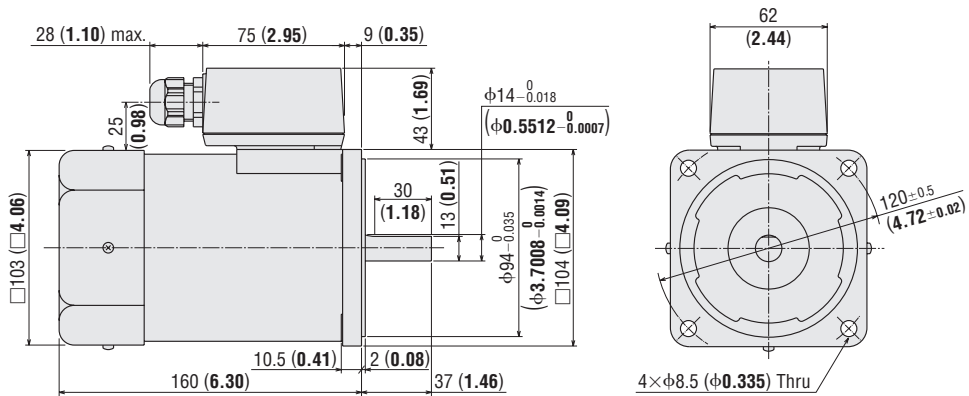

● Use cable with a diameter of $\phi 6 \sim \phi 12$ mm ($\phi 0.24 \sim \phi 0.47$ in.).

● Details of terminal box → Page C-283

Introduction

Induction Motors

Reversible Motors

Electromagnetic Brake Motors

V Series

Clutch & Brake Motors

Synchronous Motors

Low-Speed Synchronous Motors

Waterright Dust-Resistant Motors

Torque Motors

Right-Angle Gearheads

Linear Heads

Brake Pack

Accessories

Installation

◇ Capacitor (Included with single-phase motors)

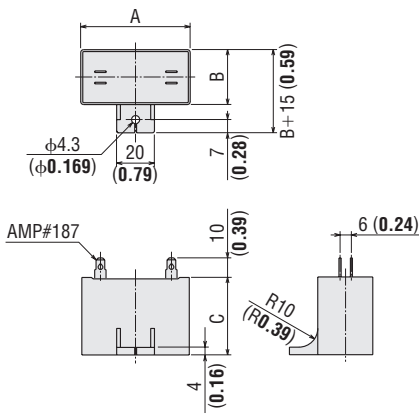

◇ Capacitor Dimensions Unit = mm (in.)

Model		Capacitor Model	A	B	C	Mass g (oz.)	Capacitor Cap
Cable Type	Terminal Box Type						
BHI62F-□RH BHI62F-□RA BHI62F-□ BHI62F-A	BHI62FT-□RH BHI62FT-□RA BHI62FT-□ BHI62FT-A	CH400CFAUL2	58 (2.28)	41 (1.61)	58 (2.28)	175 (6.2)	Included
BHI62E-□RH BHI62E-□RA BHI62E-□ BHI62E-A	BHI62ET-□RH BHI62ET-□RA BHI62ET-□ BHI62ET-A	CH100BFAUL	58 (2.28)	35 (1.38)	50 (1.97)	132 (4.7)	

● Enter the gear ratio in the box (□) within the model name.

■ Mounting Method for Right-Angle, Hollow Shaft Types

→ Page C-237

1 W, 3 W
(1/750 HP)
(1/250 HP)

6 W
(1/125 HP)

15 W
(1/50 HP)

25 W
(1/30 HP)

40 W
(1/19 HP)

60 W
(1/12 HP)

90 W
(1/8 HP)

200 W
(1/4 HP)

2-Pole
40-150 W
(1/19-1/5 HP)

Connection Diagrams

- The direction of motor rotation is as viewed from the shaft end of the motor. CW represents the clockwise direction, while CCW represents the counterclockwise direction.
- Enter the voltage (**F**, **E**) in the box (□) within the model name.

Motor Type	Single-Phase Induction Motor		Three-Phase Induction Motor	
	Cable Type BHI62□-3~9 BHI62□-50~180	Terminal Box Type* BHI62□T-3~9 BHI62□T-50~180	Cable Type BHI62S-3~9 BHI62S-50~180	Terminal Box Type* BHI62ST-3~9 BHI62ST-50~180
Combination Type: Parallel Shaft	Clockwise 	Clockwise 	Clockwise 	Clockwise
	Counterclockwise CCW 	Counterclockwise CCW 	Counterclockwise To change the rotation direction, change any two connections between L1 (R), L2 (S) and L3 (T). 	Counterclockwise To change the rotation direction, change any two connections between L1 (R), L2 (S) and L3 (T).
	BHI62□-12.5~36	BHI62□T-12.5~36	BHI62S-12.5~36	BHI62ST-12.5~36
	Clockwise 	Clockwise 	Clockwise 	Clockwise
	Counterclockwise CCW 	Counterclockwise CCW 	Counterclockwise To change the rotation direction, change any two connections between L1 (S), L2 (R) and L3 (T). 	Counterclockwise To change the rotation direction, change any two connections between L1 (S), L2 (R) and L3 (T).
	BHI62□-12.5~36	BHI62□T-12.5~36	BHI62S-12.5~36	BHI62ST-12.5~36

PE: Protective Earth

*Connecting to the terminal
 Applicable lead wires: AWG24~12
 Strip length: 8 mm (0.315 in.)

Note

● Change the direction of single-phase motor rotation only after bringing the motor to a stop. If an attempt is made to change the direction of rotation while the motor is rotating, motor may ignore reversing command or change its direction of rotation after some delay.

● How to connect a capacitor → Page C-282

1 W, 3 W
(1/250 HP)
6 W
(1/125 HP)
15 W
(1/50 HP)
25 W
(1/30 HP)
40 W
(1/19 HP)
60 W
(1/12 HP)
90 W
(1/8 HP)
200 W
(1/4 HP)
2-Pole
40-150 W
(1/19-1/5 HP)

Motor Type	Single-Phase Induction Motor		Three-Phase Induction Motor	
	Cable Type	Terminal Box Type*	Cable Type	Terminal Box Type*
Combination Type: Right Angle Shaft	BHI62□-5RH~180RH BHI62□-5RA~180RA	BHI62□T-5RH~180RH BHI62□T-5RA~180RA	BHI62S-5RH~180RH BHI62S-5RA~180RA	BHI62ST-5RH~180RH BHI62ST-5RA~180RA
	Clockwise 	Clockwise 	Clockwise 	Clockwise
	Counterclockwise 	Counterclockwise 	Counterclockwise To change the rotation direction, change any two connections between L1(S), L2(R) and L3(T).	Counterclockwise To change the rotation direction, change any two connections between L1(S), L2(R) and L3(T).
	BHI62□-A	BHI62□T-A	BHI62S-A	BHI62ST-A
Round Shaft Type	Clockwise 	Clockwise 	Clockwise 	Clockwise
	Counterclockwise 	Counterclockwise 	Counterclockwise To change the rotation direction, change any two connections between L1(R), L2(S) and L3(T).	Counterclockwise To change the rotation direction, change any two connections between L1(R), L2(S) and L3(T).

PE: Protective Earth

*Connecting to the terminal
 Applicable lead wires: AWG24~12
 Strip length: 8 mm (0.315 in.)

Note

● Change the direction of single-phase motor rotation only after bringing the motor to a stop. If an attempt is made to change the direction of rotation while the motor is rotating, motor may ignore reversing command or change its direction of rotation after some delay.

● How to connect a capacitor → Page C-282

List of Motor and Gearhead Combinations

Motor and gearhead combinations are shown below.

● Combination Type: Right Angle Shaft

Model	Motor Model	Gearhead Model
BHI62F-□RH	BHI62F-G2	BH6G2-□RH
BHI62F-□RA		BH6G2-□RA
BHI62FT-□RH	BHI62FT-G2	BH6G2-□RH
BHI62FT-□RA		BH6G2-□RA
BHI62E-□RH	BHI62E-G2	BH6G2-□RH
BHI62E-□RA		BH6G2-□RA
BHI62ET-□RH	BHI62ET-G2	BH6G2-□RH
BHI62ET-□RA		BH6G2-□RA
BHI62S-□RH	BHI62S-G2	BH6G2-□RH
BHI62S-□RA		BH6G2-□RA
BHI62ST-□RH	BHI62ST-G2	BH6G2-□RH
BHI62ST-□RA		BH6G2-□RA

● Combination Type: Parallel Shaft

Model	Motor Model	Gearhead Model
BHI62F-□	BHI62F-G2	BH6G2-□
BHI62FT-□	BHI62FT-G2	
BHI62E-□	BHI62E-G2	
BHI62ET-□	BHI62ET-G2	
BHI62S-□	BHI62S-G2	
BHI62ST-□	BHI62ST-G2	

Accessories and Peripheral Equipment

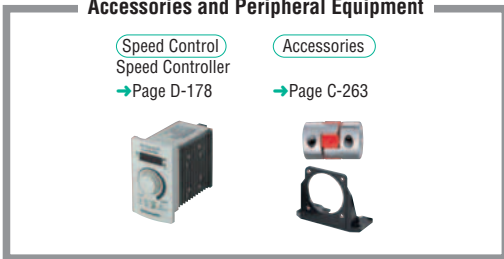

● Enter the gear ratio in the box (□) within the model name.