

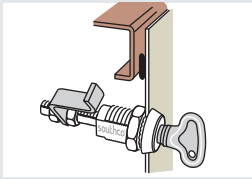

# E3 VISE ACTION® Compression Latch

## Overview



First 90° turn:  
Cam rotates behind frame

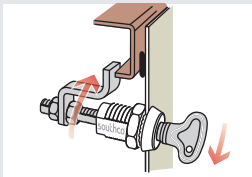

The door is now **latched**  
against opening

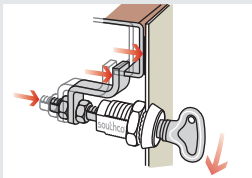

Then as you complete the  
half-turn motion, the shaft  
and cam compress to pull the  
door snugly against the frame  
or gasket into the  
**locked** position

## Versatility and simplicity in action

Every **SOUTHCO® VISE ACTION®** Series latch solution starts with the single-turn latching and compressing action that is built into each model. At the heart of it all is our **VISE ACTION®** design that has proven itself in millions of installations.

### Product features

- Suitable for a wide range of load configurations
- Excellent corrosion resistance
- Durable and reliable operation
- Multiple size, material and access configurations
- Compression achieved with minimal manual torque
- Suitable for NEMA 4 / IP65 applications

### ➤ Match material and finish options for style and functionality requirements

Variety of materials and finishes to complement your application.

Die-cast zinc latch bodies standard finishes:



Chrome plated



Black powder  
coated



Silver powder  
coated

Stainless steel latch bodies are made by metal injection molding or precise machining.

Aluminum latch bodies standard finishes:



Black powder  
coated



Silver powder  
coated



Black hard  
anodized



Clear powder  
coated

### ➤ Select one of these three housing styles to fit your access requirements

A series of basic housing styles of the **VISE ACTION®** compression latch have been developed to meet specific door configuration and mounting requirements - for depth, thickness, strength, grip dimension, and surface protrusion.

- Right and left hand actuation
- Optional pre-assembled cam for quick installation
- Wide choice of accessories

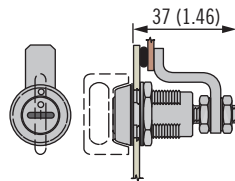

#### 13.5mm Size

- Optimum compression for use in confined space applications

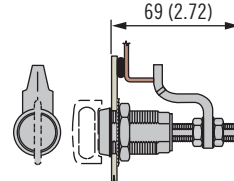

#### 19.1mm Size

- Largest choice of head styles
- Maximum grip range in door to frame spacing
- Minimal protrusion style available

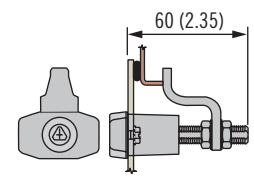

#### 3-Hole Mount

- Simplified round-hole mounting
- Suitable for thick, soft or weak panels

Other options available. For complete details on variety, part numbers, installation and specification, go to



[www.southco.com](http://www.southco.com)

Dimensions in millimeters (inch) unless otherwise stated

**southco®**  
CONNECT · CREATE · INNOVATE

➔ Choose from a wide range of head styles to fit your application and industry requirements

- ➔ Convenient hand operated knob or T-handle styles for easy repetitive access
- ➔ Tool operated for restricted access, flush mount or low profile clearances, and industry specific standards or requirements
- ➔ Key operated for added security

13.5mm single hole door preparation

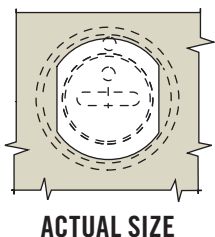

3-Hole body door preparation

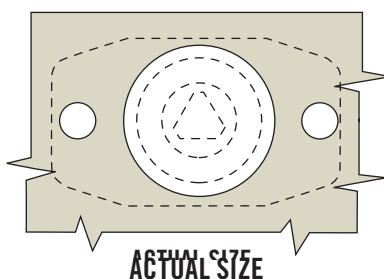
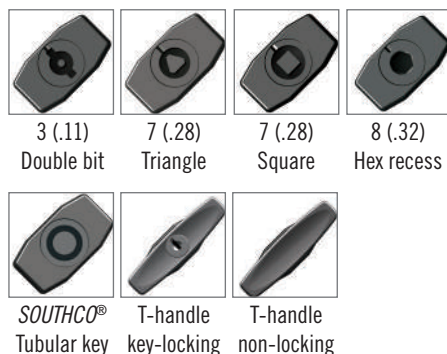

19.1mm single hole body door preparation

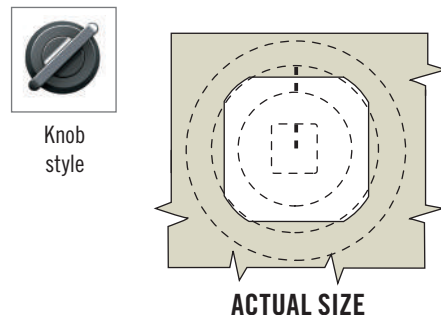
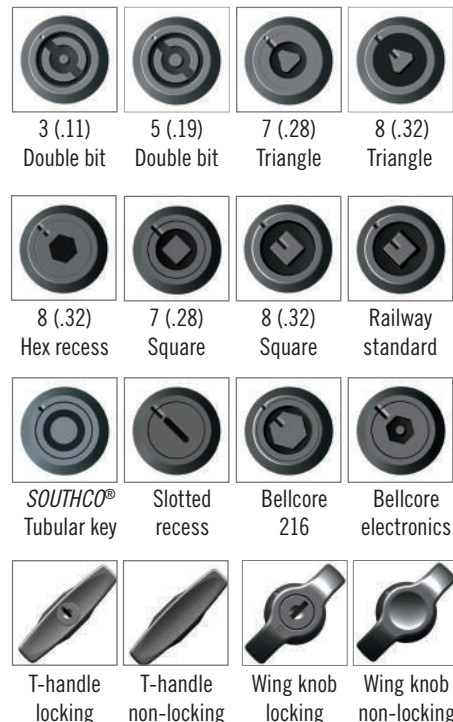

➔ Determine your grip options for a perfect fit

Grip dimension is an important consideration in compression latch applications involving gaskets for environmental or RFI sealing.

For gasketed doors:

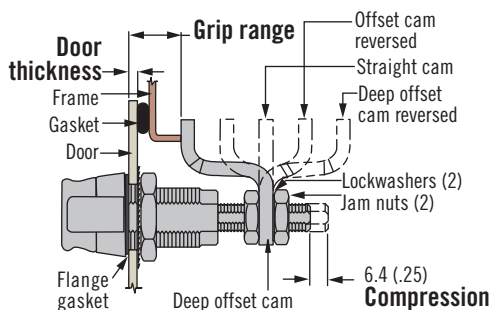
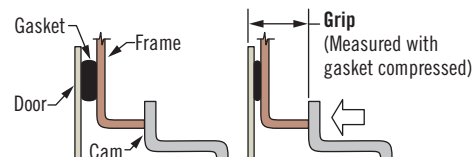

Adjustable cam designs

- Maximum flexibility in tolerance or gasket compression
- Cam choice to suit a broad range of grip dimensions

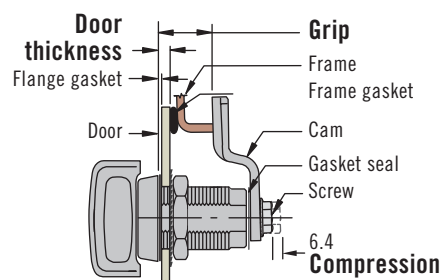

Fixed cam designs

- Precise fit and minimum internal protrusion
- Wide cam selection for accurate grip dimension



# E3 VISE ACTION® Compression Latch

Machined stainless steel housing · Tool operated  
Adjustable grip · 19.1mm size

- Consistent pre-set compression
- Easy grip adjustment
- Premium finish and corrosion resistance
- EN 45545-3 E60 Compliant

### Material and Finish

Stainless steel (304 and 316 machined)

### Performance Details

Maximum static load:  
600 N (136 lbf)

### Sealing Notes

NEMA 4 and IP65 enabled using gasket supplied

### Keys and Accessories

See page 90

### Installation Notes

**Caution:** Position cam so latching function can be achieved comfortably by hand.  
Recommended tightening torque for the mounting nut is 20 N·m (176 in·lbf).

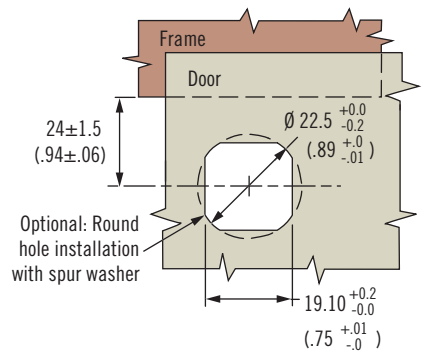
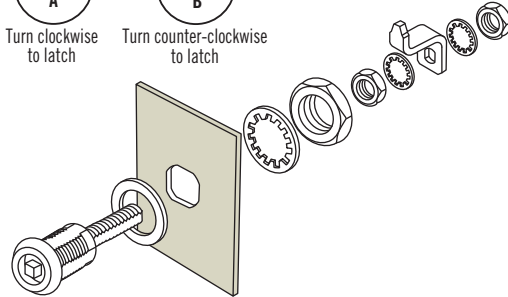
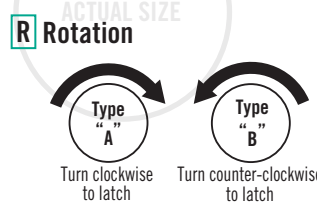
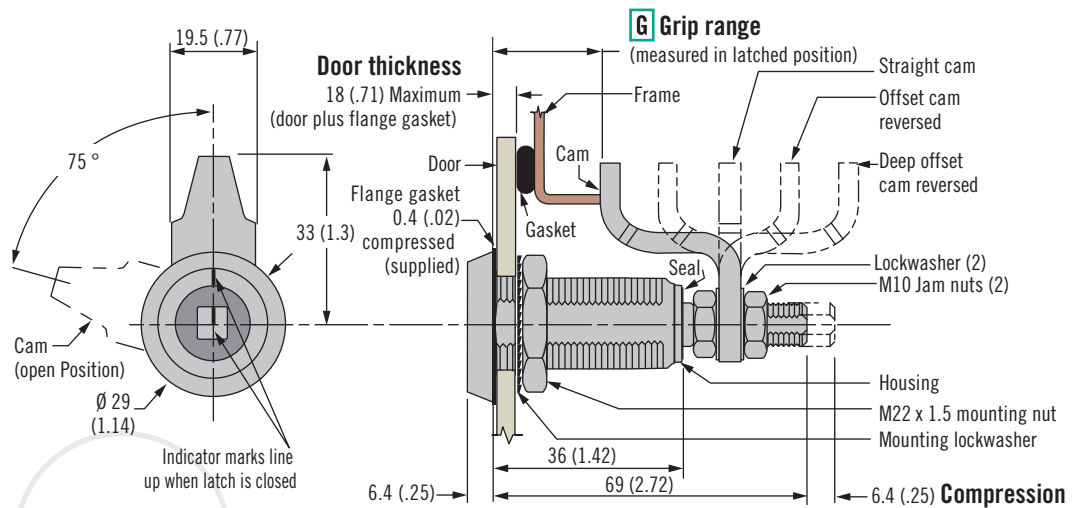

### H Head Styles

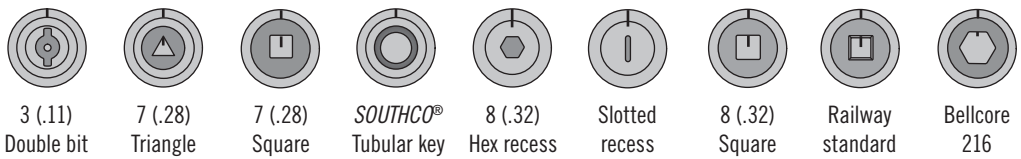

### Part Number Selection

See table

H Head Style	R Rotation	G Grip	Minimum	Maximum	Cam Type
2 3 (.11) Double bit	9 Slotted recess	1	16.4 (.64)	32.2 (1.26)	Deep offset cam, forward
3 7 (.28) Triangle	10 8 (.32) Square		71.3 (2.80)	81.2 (3.19)	Deep offset cam, reversed
4 7 (.28) Square	11 Railway standard	2	30.4 (1.19)	46.1 (1.81)	Offset cam, forward
5 SOUTHCO® Tubular key	15 Bellcore 216		57.6 (2.26)	73.3 (2.88)	Offset cam, reversed
6 8 (.32) Hex recess		3	43.9 (1.72)	59.6 (2.34)	Straight cam

**E3 - R H - G O**

Other options available. For complete details on variety, part numbers, installation and specification, go to



[www.southco.com/E3](http://www.southco.com/E3)

Dimensions in millimeters (inch) unless otherwise stated



# E3 VISE ACTION® Compression Latch

Machined stainless steel housing · Tool operated

Fixed grip · 19.1mm size

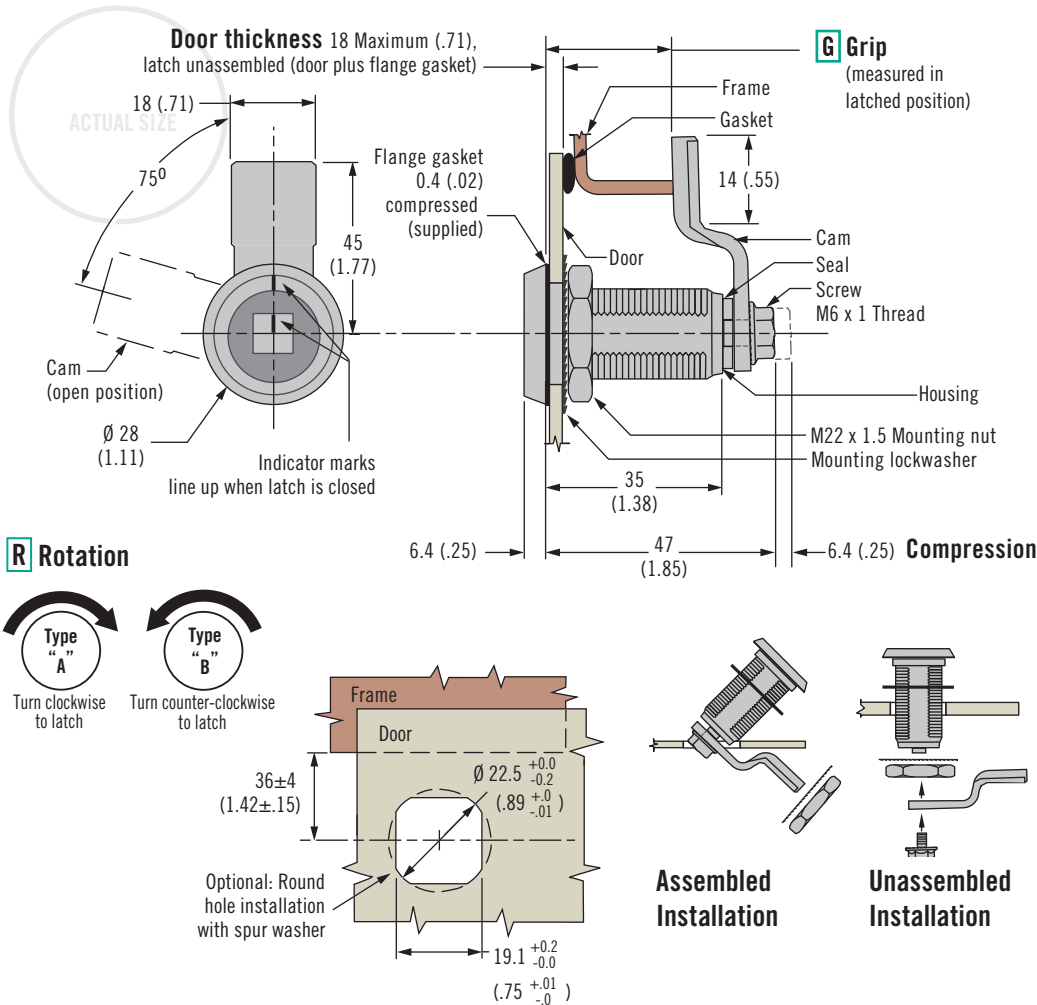

- Consistent pre-set compression
- Premium finish and corrosion resistance
- Reduced internal protrusion
- EN 45545-3 E60 Compliant

### Material and Finish

Stainless steel (304 and 316 machined)

### Performance Details

Maximum static load:  
450 N (100 lbf)

### Sealing Notes

NEMA 4 and IP65 enabled using gasket supplied

### Keys and Accessories

See page 90

### Installation Notes

Recommended tightening torque for the mounting nut is 20 N·m (176 in·lbf), and for the mounting screw is 10 N·m (88 in·lbf)

### Part Number Selection

See table

Select grip from table, if your grip is between two options choose smaller.

### H Head style

- 2 3 (.11) Double bit
- 3 7 (.28) Triangle
- 4 7 (.28) Square
- 5 SOUTHCO® Tubular key
- 6 8 (.32) Hex recess
- 9 Slotted recess
- 10 8 (.32) Square
- 11 Railway standard
- 15 Bellcore 216

### R Rotation

- 10 Type A clockwise to latch - Latch assembled
- 12 Type A clockwise to latch - Latch unassembled
- 27 Type B counter-clockwise to latch - Latch assembled
- 29 Type B counter-clockwise to latch - Latch unassembled

E3 - R H - G O

### G Grip Table

Total Grip	G	Max. Door Thickness for Assembled Latch	Total Grip	G	Max. Door Thickness for Assembled Latch	Total Grip	G	Max. Door Thickness for Assembled Latch	Total Grip	G	Max. Door Thickness for Assembled Latch
20 (.79)	00	1 (.04)	30 (1.18)	05	7 (.28)	40 (1.57)	10	7 (.28)	50 (1.97)	15	7 (.28)
22 (.87)	01	2 (.08)		06			11		52 (2.05)	16	
24 (.94)	02	4 (.16)		07			12		54 (2.13)	17	
26 (1.02)	03	5 (.20)		08			13		56 (2.20)	18	
28 (1.10)	04	6 (.24)		09			14		58 (2.28)	19	



# E3 VISE ACTION® Compression Latch

Machined stainless steel housing · Tool operated  
High-pressure sealed · 19.1mm size



- Consistent pre-set compression
- Premium finish and corrosion resistance
- IP69K Compliant
- Easy Clean
- Conform to DIN EN 1672-2

**Material and Finish**  
Stainless Steel 316

**Performance Details**  
Adjustable Grip - Maximum static load: 600N (136 lbf)  
Fixed Grip - Maximum static load: 450N (100 lbf)

**Keys**  
Use Southco key E3-17-1 only

**Installation Notes**  
Recommended tightening torque for the mounting nut is 20 N·m (176 in·lbf).

**Accessories**  
Replacement flange gasket:  
Part number: E5-17-101

**Part Number Selection**  
See table  
Order latch and cam separately

Other options available. For complete details on variety, part numbers, installation and specification, go to

**INFO CLIC** [www.southco.com/E3](http://www.southco.com/E3)

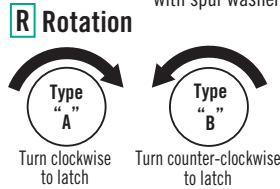
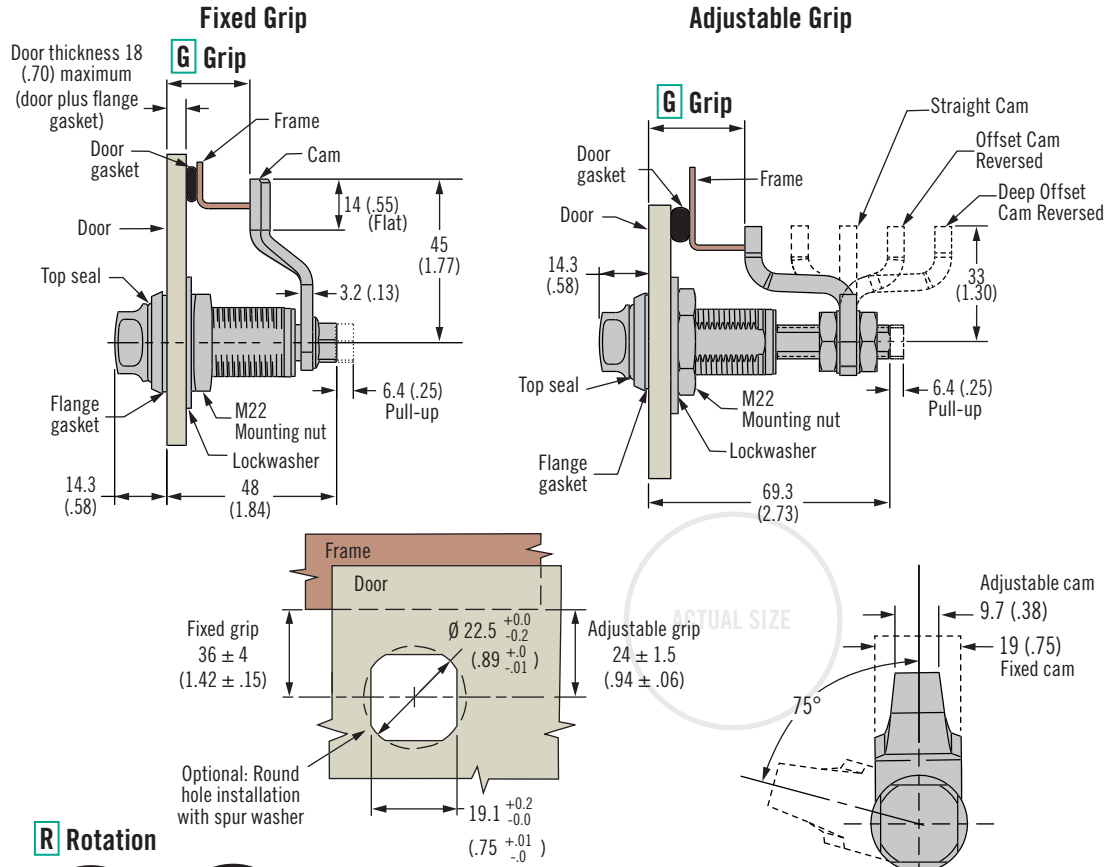

**E3 - H R 38 - G 0**

- R Rotation**
- Adjustable Grip  
1 Type A clockwise to latch  
22 Type B counter-clockwise to latch
- Fixed Grip  
12 Type A clockwise to latch  
29 Type B counter-clockwise to latch

**G Grip**

0 Adjustable Grip  
UU Fixed Grip

Fixed Grip Cam part number			
Grip	Part Number	Grip	Part Number
20 (.79)	E5-1200-24	40 (1.57)	E5-1210-24
22 (.87)	E5-1201-24	42 (1.65)	E5-1211-24
24 (.94)	E5-1202-24	44 (1.73)	E5-1212-24
26 (1.02)	E5-1203-24	46 (1.81)	E5-1213-24
28 (1.10)	E5-1204-24	48 (1.89)	E5-1214-24
30 (1.18)	E5-1205-24	50 (1.97)	E5-1215-24
32 (1.26)	E5-1206-24	52 (2.05)	E5-1216-24
34 (1.34)	E5-1207-24	54 (2.13)	E5-1217-24
36 (1.42)	E5-1208-24	56 (2.20)	E5-1218-24
38 (1.50)	E5-1209-24	58 (2.28)	E5-1219-24

Adjustable Grip Cam part number			
Minimum Grip	Maximum Grip	Cam Type	Part Number
16.4 (.64)	32.2 (1.26)	Deep offset cam, forward	E3-28-201-24
71.3 (2.80)	81.2 (3.19)	Deep offset cam, reversed	
30.4 (1.19)	46.1 (1.81)	Offset cam, forward	E3-28-202-24
57.6 (2.26)	73.3 (2.88)	Offset cam, reversed	
43.9 (1.72)	59.6 (2.34)	Straight cam	E3-28-203-24

Dimensions in millimeters (inch) unless otherwise stated





# E3 VISE ACTION® Compression Latch

Stainless Steel Housing · Tool operated

Bi-Stable Cover Series · Fixed or Adjustable grip · 19.1mm size

- Consistent pre-set compression
- Designed to work with separate bi-stable cover with fin
- Cover pops open when latch is not secure, providing visual indication of latch status
- Corrosion Resistance
- EN 45545-3 E60 Compliant

## Material and Finish

Latch: Stainless steel 316 and 304

Cover: Stainless steel 316

## Performance Details

Compression: 6.4 mm (.25 in)

Adjustable Grip: Maximum static load: 600 N (136 lbf)

Fixed Grip: Maximum static load: 450 N (100 lbf)

## Sealing Notes

NEMA 4 and IP65 enabled using gasket supplied

## Installation Notes

Recommended tightening torque for the mounting nut is 15 N-m (133 in-lbf).

Adjustable Grip: Position cam so latching function can be achieved comfortably by hand.

Fixed Grip: Mounting screw torque 10 N-m (88 in-lbf)

## Keys and Accessories

See page 90 (modified head styles work with standard keys)

**Make Safety Visible™**  
by Southco

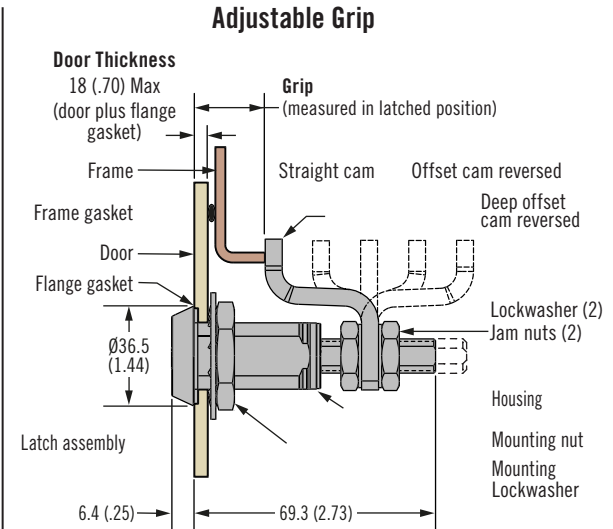
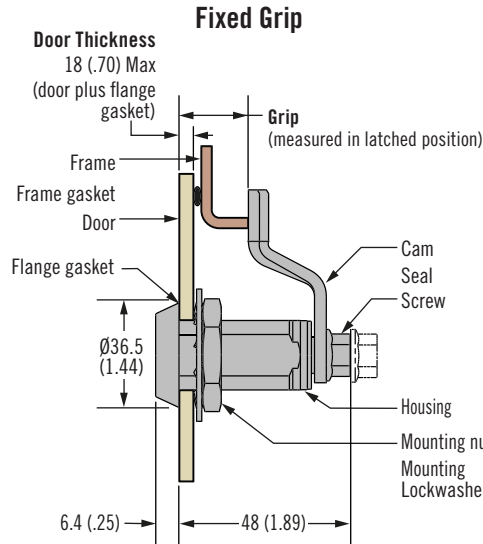

## Bi-Stable Cover Latch

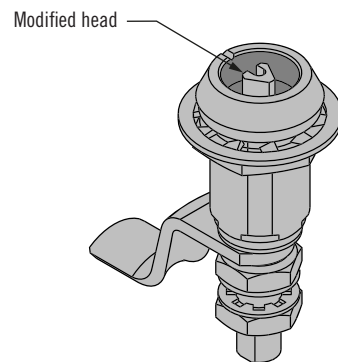

## Bi-Stable Cover with fin

Part number E3-80-251-40 (ordered separately)

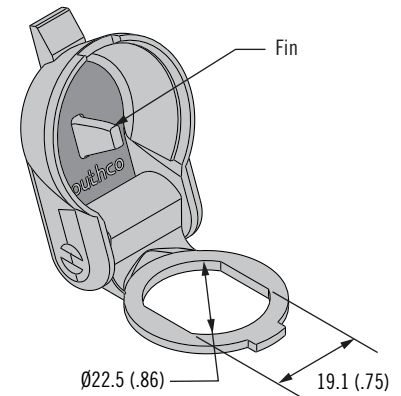

## Cover in open position

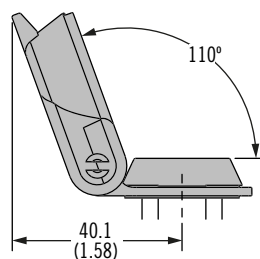

## Cover returns to open position

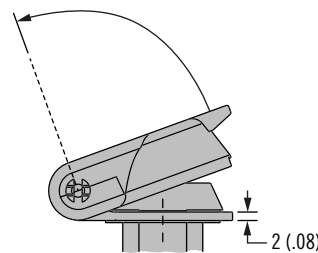

## Cover in closed position

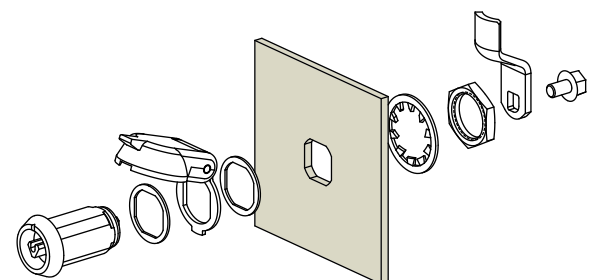
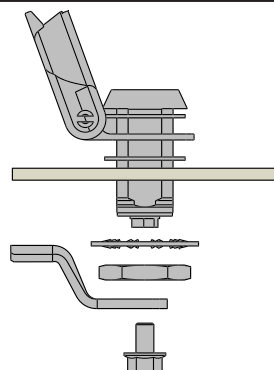
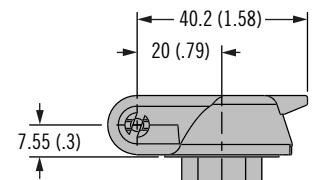

[www.southco.com/E3](http://www.southco.com/E3)

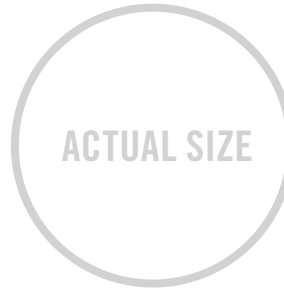
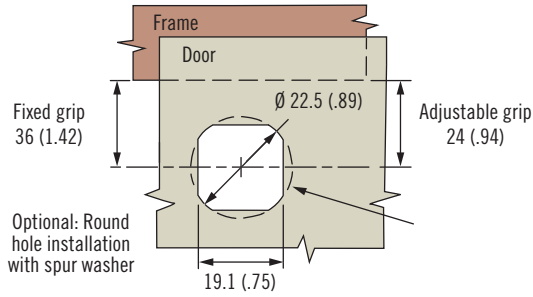

**H** Head Styles

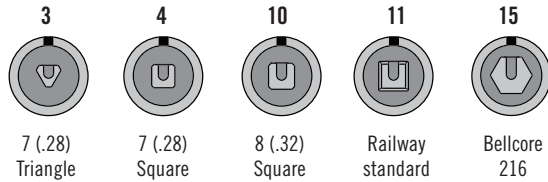

**Fixed Grip**

**R** Rotation

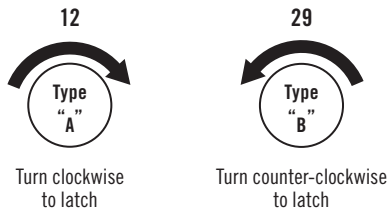

**Adjustable Grip**

**R** Rotation

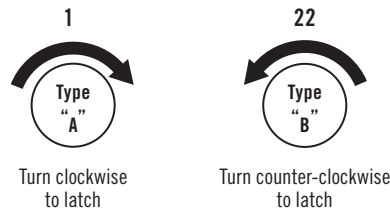

**E3 - R H B - UUO**

**E3 - R H B - 00**

Cam Part Number (order separately from latch)			
Grip	Part Number	Grip	Part Number
20 (.79)	E5-1200-24	40 (1.57)	E5-1210-24
22 (.87)	E5-1201-24	42 (1.65)	E5-1211-24
24 (.94)	E5-1202-24	44 (1.73)	E5-1212-24
26 (1.02)	E5-1203-24	46 (1.81)	E5-1213-24
28 (1.10)	E5-1204-24	48 (1.89)	E5-1214-24
30 (1.18)	E5-1205-24	50 (1.97)	E5-1215-24
32 (1.26)	E5-1206-24	52 (2.05)	E5-1216-24
34 (1.34)	E5-1207-24	54 (2.13)	E5-1217-24
36 (1.42)	E5-1208-24	56 (2.20)	E5-1218-24
38 (1.50)	E5-1209-24	58 (2.28)	E5-1219-24

Cam Part Number (order separately from latch)			
Minimum Grip	Maximum Grip	Cam Type	Part Number
16.4 (.64)	32.2 (1.26)	Deep offset cam, forward	E3-28-201-24
71.3 (2.80)	81.2 (3.19)	Deep offset cam, reversed	
30.4 (1.19)	46.1 (1.81)	Offset cam, forward	E3-28-202-24
57.6 (2.26)	73.3 (2.88)	Offset cam, reversed	
43.9 (1.72)	59.6 (2.34)	Straight cam	E3-28-203-24

**Part Number Selection**

See table  
 Order Latch and Cam separately  
 Bi-Stable Cover with fin:  
 E3-80-251-40  
 Select grip from Cam table.  
 For Fixed Grip, if your grip is between two options choose the smaller grip

Other options available. For complete details on variety, part numbers, installation and specification, go to

**INFO CLIC** [www.southco.com/E3](http://www.southco.com/E3)





# E3 VISE ACTION® Compression Latch

Metal injection molding stainless steel housing · Tool or hand operated  
Adjustable grip · 19.1mm size

- Consistent pre-set compression
- Easy grip adjustment
- Tool or hand operated
- EN 45545-3 E60 Compliant

### Material and Finish

Stainless steel 316 and 304

### Performance Details

Maximum static load:  
556 N (125 lbf)

### Sealing Notes

NEMA 4 and IP65 enabled using gasket supplied

### Installation Notes

**Caution:** Position cam so latching function can be achieved comfortably by hand.

Recommended tightening torque for the mounting nut is 20 N·m (176 in·lbf).

### Keys and Accessories

See page 90

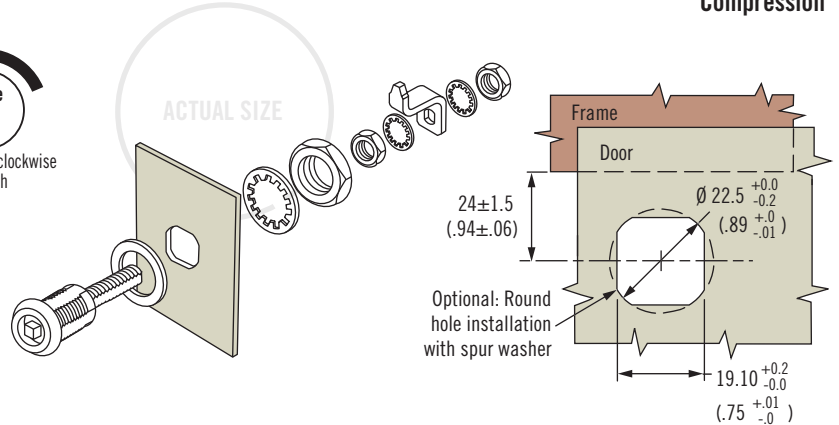
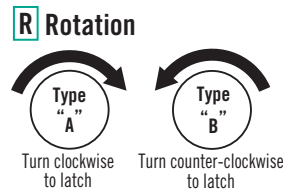
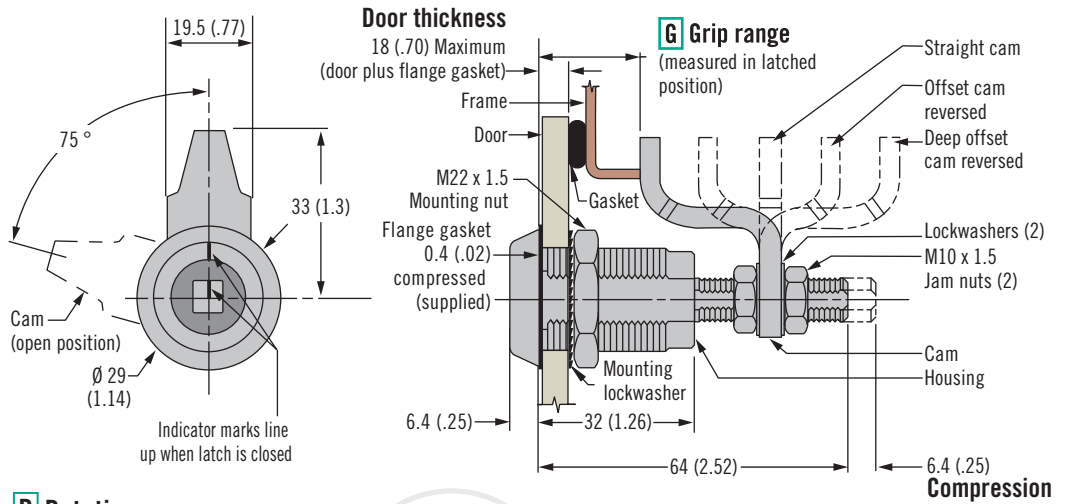

### H Head Styles

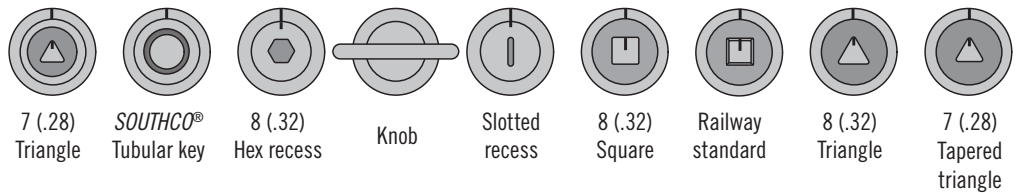

### Part Number Selection

See table

	<b>G</b> Grip	Minimum	Maximum	Cam Type
1	R	11.4 (.45)	27.2 (1.07)	Deep offset cam, forward
		66.3 (2.61)	76.2 (3.00)	Deep offset cam, reversed
2	H	25.4 (1.00)	41.1 (1.62)	Offset cam, forward
		52.6 (2.07)	68.3 (2.69)	Offset cam, reversed
3	F	38.9 (1.53)	54.6 (2.15)	Straight cam

**R** Rotation  
1 Type A clockwise to latch  
22 Type B counter-clockwise to latch

**F** Finish  
2 Electropolished  
12 Electropolished and hand buffed (bright)

**H** Head style  
3 7 (.28) Triangle  
5 SOUTHCO® Tubular key  
6 8 (.32) Hex recess  
7 Knob  
9 Slotted recess  
10 8 (.32) Square  
11 Railway standard  
20 8 (.32) Triangle  
39 7 (.28) Tapered triangle

Other options available. For complete details on variety, part numbers, installation and specification, go to

**INFO CLIC** [www.southco.com/E3](http://www.southco.com/E3)

Dimensions in millimeters (inch) unless otherwise stated



# E3 VISE ACTION® Compression Latch

Metal injection molding stainless steel housing · Tool or hand operated

Fixed grip · 19.1mm size

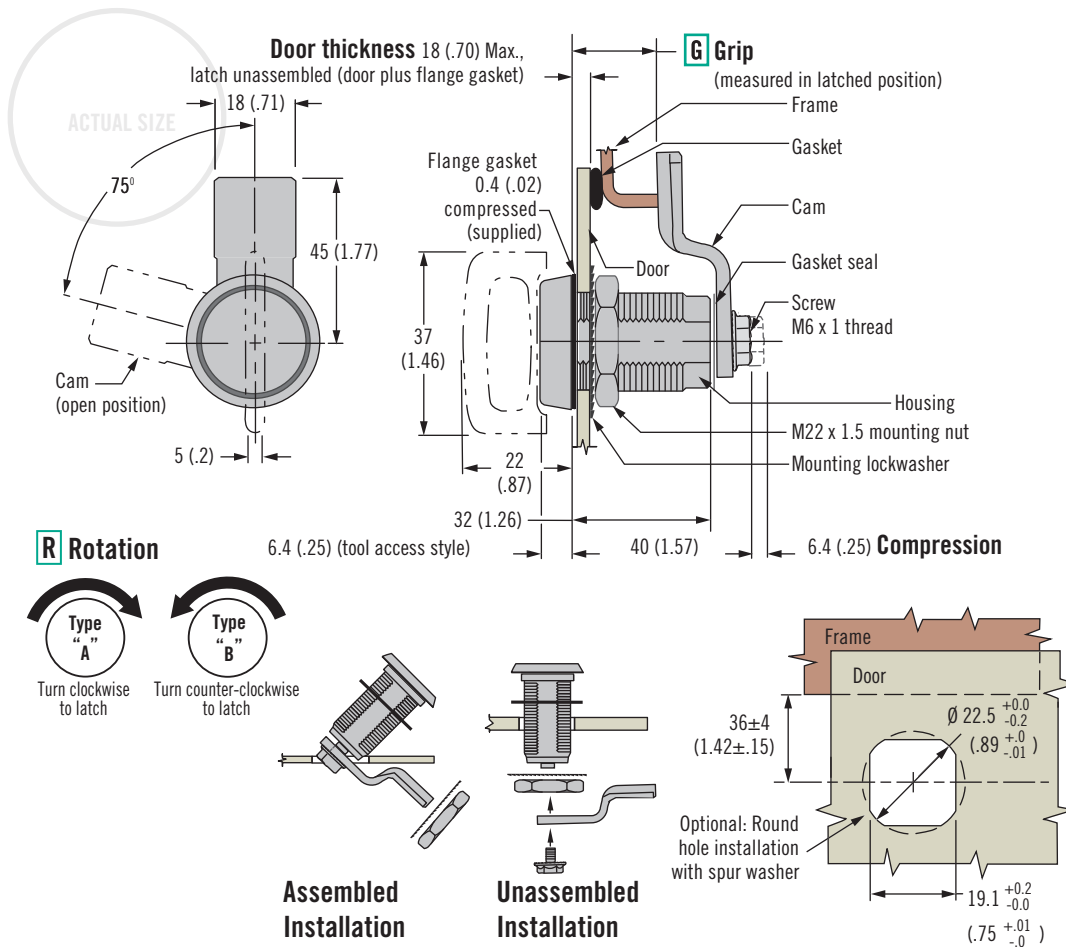

- Consistent pre-set compression
- Tool or hand operated
- Reduced internal protrusion
- EN 45545-3 E60 Compliant

### Material and Finish

Stainless steel 316 and 304

### Performance Details

Maximum static load:  
450 N (100 lbf)

### Sealing Notes

NEMA 4 / IP65 enabled using gasket supplied

### Installation Notes

Recommended tightening torque for the mounting nut is 20 N·m (176 in·lbf), and for the mounting screw in 10 N·m (88 in·lbf)

### Keys and Accessories

See page 90

### Part Number Selection

See table

Select grip from table, if your grip is between two options choose smaller.

### H Head style

- 3 7 (.28) Triangle
- 5 SOUTHCO® Tubular key
- 6 8 (.32) Hex recess
- 7 Knob
- 9 Slotted recess
- 10 8 (.32) Square
- 11 Railway standard
- 20 8 (.32) triangle
- 39 7 (.28) Tapered triangle

**E3 - R H - G F**

### R Rotation

- 10 Type A clockwise to latch - Latch assembled
- 12 Type A clockwise to latch - Latch unassembled
- 27 Type B counter-clockwise to latch - Latch assembled
- 29 Type B counter-clockwise to latch - Latch unassembled

### F Finish

- 2 Electropolished
- 12 Electropolished and hand buffed (bright)

### G Grip Table

Total Grip	G	Max. Door Thickness for Assembled Latch	Total Grip	G	Max. Door Thickness for Assembled Latch	Total Grip	G	Max. Door Thickness for Assembled Latch	Total Grip	G	Max. Door Thickness for Assembled Latch
15 (.59)	00	Use unassembled	25 (.98)	05	5 (.20)	35 (1.38)	10	7 (.28)	45 (1.77)	15	7 (.28)
17 (.67)	01	Use unassembled	27 (1.06)	06	6 (.24)	37 (1.46)	11		47 (1.85)	16	
19 (.75)	02	1 (.04)	29 (1.14)	07	7 (.28)	39 (1.53)	12		49 (1.93)	17	
21 (.83)	03	2 (.08)	31 (1.22)	08		41 (1.61)	13		51 (2.01)	18	
23 (.91)	04	4 (.16)	33 (1.30)	09		43 (1.69)	14		53 (2.09)	19	



# E3 VISE ACTION® Compression Latch

Cast 316 stainless steel housing · Hand operated  
Adjustable grip · 19.1mm size

- Consistent pre-set compression
- Easy grip adjustment
- Premium finish and corrosion resistance
- EN 45545-3 E60 Compliant

### Material and Finish

Stainless steel

### Performance Details

Maximum static load:  
600 N (136 lbf)

### Sealing Notes

NEMA 4 and IP65 enabled using gasket supplied

### Installation Notes

**Caution:** Position cam so latching function can be achieved comfortably by hand.

Recommended tightening torque for the mounting nut is 20 N·m (176 in·lbf).

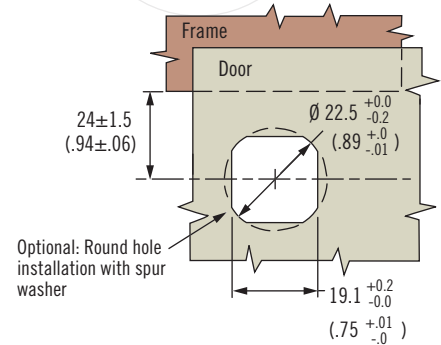
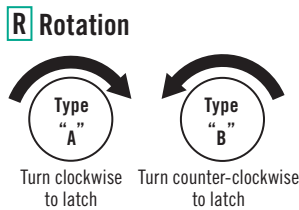
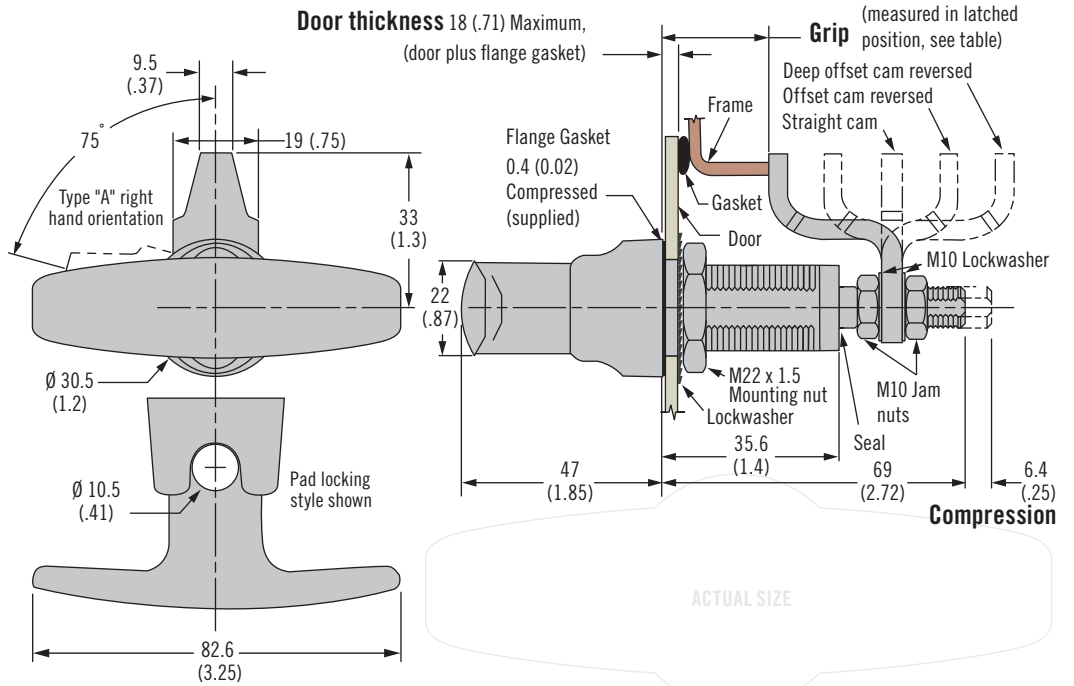

### Part Number Selection

See table

Order latch and cam separately

### Latch Part Number (no cam)

Cam Part Number Table (order separately from latch)			
Minimum Grip	Maximum Grip	Cam Type	Part Number
16.4 (.64)	32.2 (1.26)	Deep offset cam, forward	E3-28-201-24
71.3 (2.80)	81.2 (3.19)	Deep offset cam, reversed	
30.4 (1.19)	46.1 (1.81)	Offset cam, forward	E3-28-202-24
57.6 (2.26)	73.3 (2.88)	Offset cam, reversed	
43.9 (1.72)	59.6 (2.34)	Straight cam	E3-28-203-24

E3 - R H - 012

- R** Rotation  
 1 Type A clockwise to latch  
 22 Type B counter-clockwise to latch
- H** Head Style  
 1 Non-locking  
 60 Padlocking

Other options available. For complete details on variety, part numbers, installation and specification, go to



Dimensions in millimeters (inch) unless otherwise stated

# E3 VISE ACTION® Compression Latch

Cast 316 stainless steel housing · Hand operated  
Fixed grip · 19.1mm size

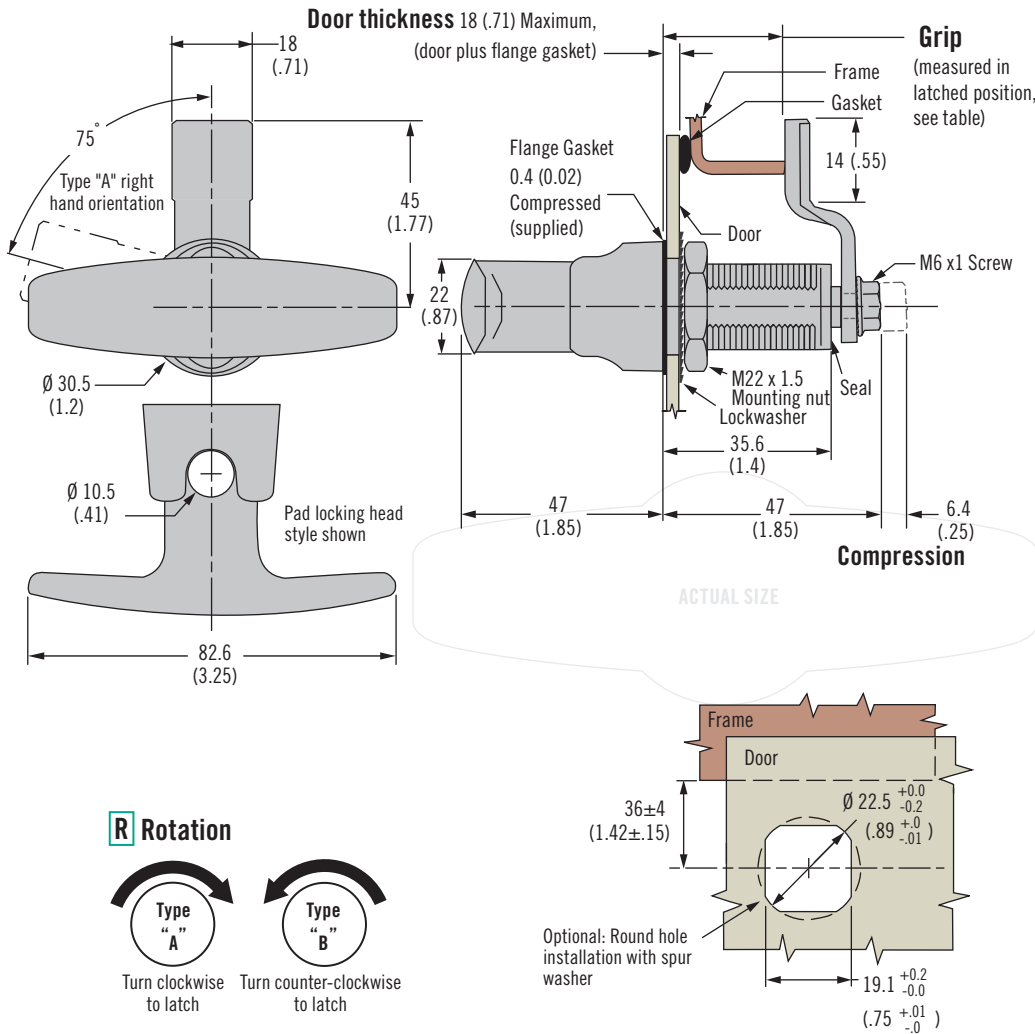

- Consistent pre-set compression
- Reduced internal protrusion
- Premium finish and corrosion resistance
- EN 45545-3 E60 Compliant

## Material and Finish

Stainless steel

## Performance Details

Maximum static load:  
450 N (100 lbf)

## Sealing Notes

NEMA 4 and IP65 enabled using gasket supplied

## Installation Notes

Recommended tightening torque for the mounting nut is 20 N·m (176 in·lbf), and for mounting screw 10 N·m (88 in·lbf).

## Latch Part Number (no cam)

**E3 - R H - UU12**

- R Rotation**
- 12 Type A clockwise to latch
  - 29 Type B counter-clockwise to latch
- H Head Style**
- 1 Non-locking
  - 60 Padlocking

## Part Number Selection

See table  
Order latch and cam separately

Select grip from table, if your grip is between two options choose smaller.

## Cam Part Number Table (order separately from latch)

Grip	Part Number	Grip	Part Number	Grip	Part Number	Grip	Part Number
20 (.79)	E5-1200-24	30 (1.18)	E5-1205-24	40 (1.57)	E5-1210-24	50 (1.97)	E5-1215-24
22 (.87)	E5-1201-24	32 (1.26)	E5-1206-24	42 (1.65)	E5-1211-24	52 (2.05)	E5-1216-24
24 (.94)	E5-1202-24	34 (1.34)	E5-1207-24	44 (1.73)	E5-1212-24	54 (2.13)	E5-1217-24
26 (1.02)	E5-1203-24	36 (1.42)	E5-1208-24	46 (1.81)	E5-1213-24	56 (2.20)	E5-1218-24
28 (1.10)	E5-1204-24	38 (1.50)	E5-1209-24	48 (1.89)	E5-1214-24	58 (2.28)	E5-1219-24



# E3 VISE ACTION® Compression Latch

Metal injection molding stainless steel housing · Tool or hand operated  
Adjustable grip · 13.5mm size

- Consistent pre-set compression
- Easy grip adjustment
- Tool or hand operated
- Reduced dimensions
- EN 45545-3 E60 Compliant

**Material and Finish**  
Stainless steel 316 and 304

**Performance Details**  
Maximum static load: 356 N (80 lbf)

**Sealing Notes**  
NEMA 4 / IP65 enabled using gasket supplied

**Installation Notes**  
**Caution:** Position cam so latching function can be achieved comfortably by hand.

**Accessories**  
See page 90

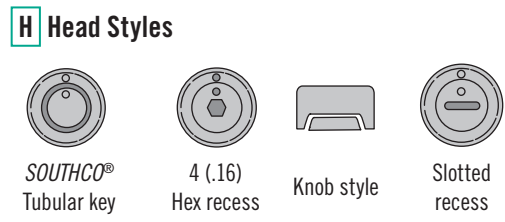
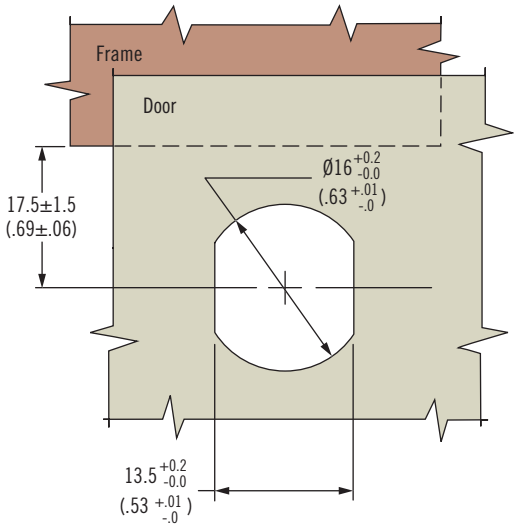
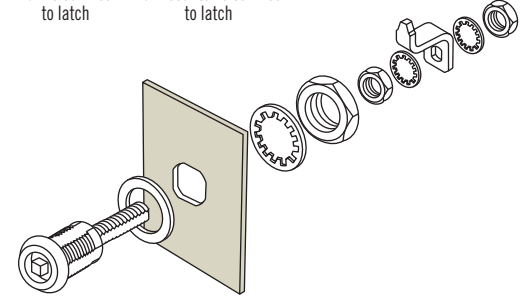
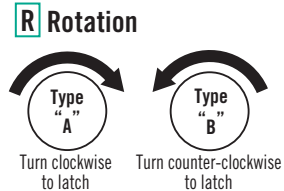
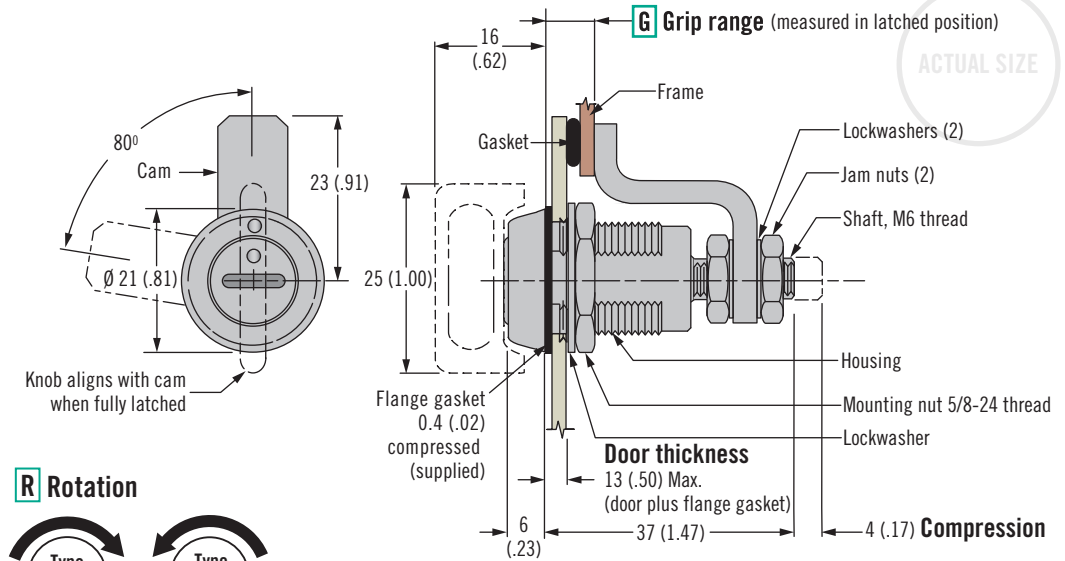

**Part Number Selection**  
See table

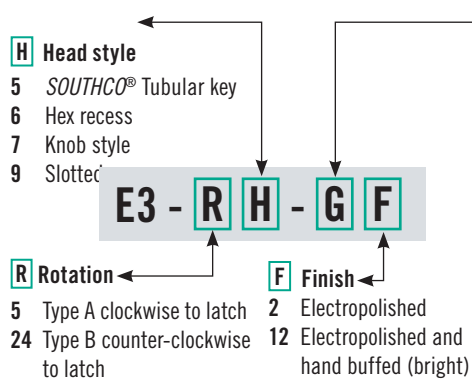

G Grip	Minimum	Maximum
1	3.2 (.13)	6.4 (.25)
2	6.4 (.25)	9.5 (.37)
3	9.5 (.37)	12.7 (.50)
4	12.7 (.50)	15.9 (.63)
5	15.9 (.63)	19 (.75)
6	19 (.75)	22.2 (.87)
7	22.2 (.87)	25.4 (1)
8	25.4 (1)	28.6 (1.13)

Other options available. For complete details on variety, part numbers, installation and specification, go to



Dimensions in millimeters (inch) unless otherwise stated



# E3 VISE ACTION® Compression Latch

Zinc and plated steel · Tool or hand operated

Adjustable grip · 13.5mm size

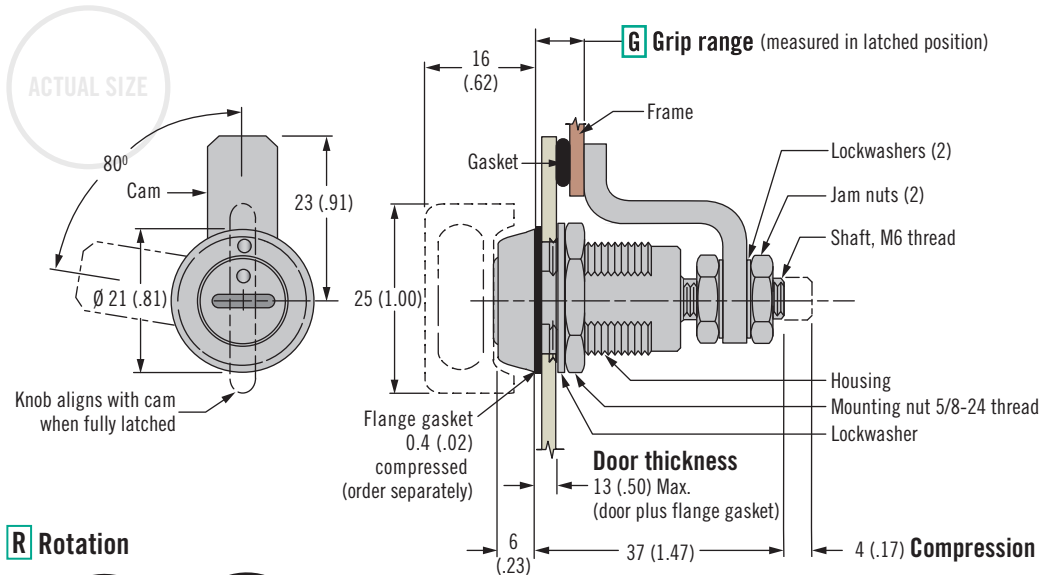

## R Rotation

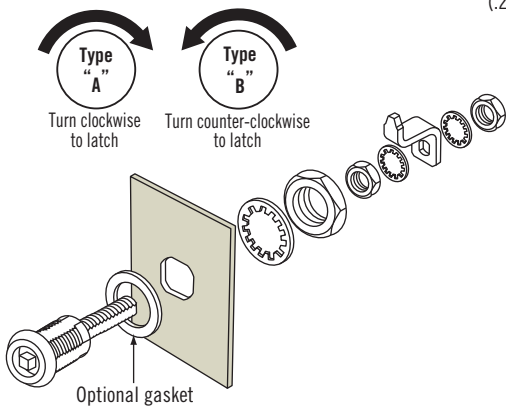

## H Head Styles

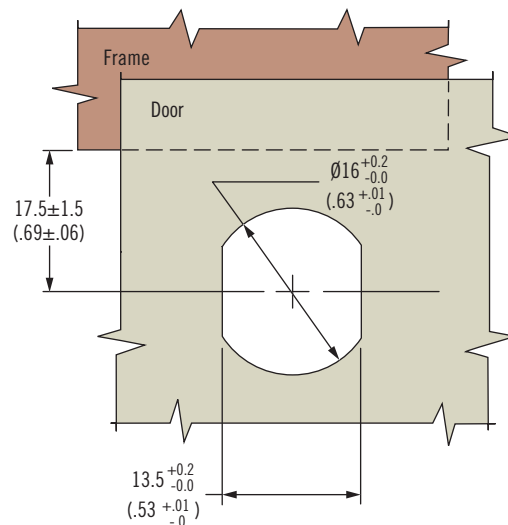
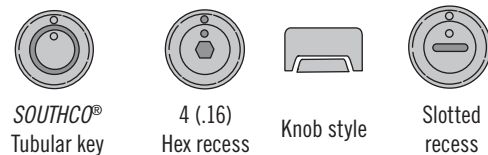

- Consistent pre-set compression
- Easy grip adjustment
- Tool or hand operated
- Reduced dimensions
- EN 45545-3 E10 Compliant

## Material and Finish

Zinc alloy, powder coated and steel, zinc plated

## Performance Details

Maximum static load: 330 N (75 lbf)

## Sealing Notes

NEMA 4 / IP65 sealing is enabled by using optional flange gasket. Flange gasket part number: E3-0-30268-02

## Installation Notes

**Caution:** Position cam so latching function can be achieved comfortably by hand.

## Accessories

See page 90

## Part Number Selection

See table

## H Head style

- 5 SOUTHCO® Tubular key
- 6 Hex recess
- 7 Knob style
- 9 Slotted recess

E3 - R H - G F

## R Rotation

- 5 Type A clockwise to latch
- 24 Type B counter-clockwise to latch

## F Finish

- 1 Chrome plated
- 5 Black powder coated
- 7 Silver powder coated

G Grip	Minimum	Maximum
1	3.2 (.13)	6.4 (.25)
2	6.4 (.25)	9.5 (.37)
3	9.5 (.37)	12.7 (.50)
4	12.7 (.50)	15.9 (.63)
5	15.9 (.63)	19 (.75)
6	19 (.75)	22.2 (.87)
7	22.2 (.87)	25.4 (1)
8	25.4 (1)	28.6 (1.13)



# E3 VISE ACTION® Compression Latch

Zinc and plated steel · Tool or hand operated  
Adjustable grip · 19.1mm size

- Consistent pre-set compression
- Easy grip adjustment
- Tool operated for security
- EN 45545-3 E10 Compliant

### Material and Finish

Zinc alloy, powder coated or chrome plated and steel, zinc plated

### Performance Details

Maximum static load:  
450 N (100 lbf)

### Sealing Notes

NEMA 4 / IP65 sealing is enabled by using optional flange gasket.  
Flange gasket part number: E5-17

### Installation Notes

**Caution:** Position cam so latching function can be achieved comfortably by hand.  
Recommended tightening torque for the mounting nut is 20 N·m (176 in·lbf).

### Keys and Accessories

See page 90

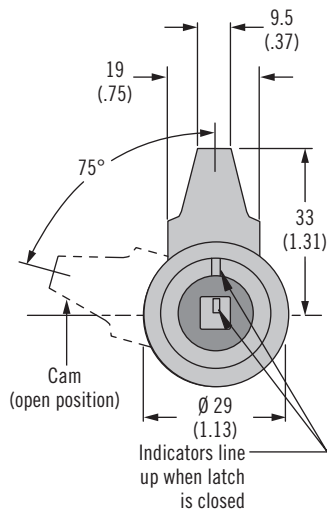

### Door thickness

18 (.70) Maximum (door plus flange gasket)

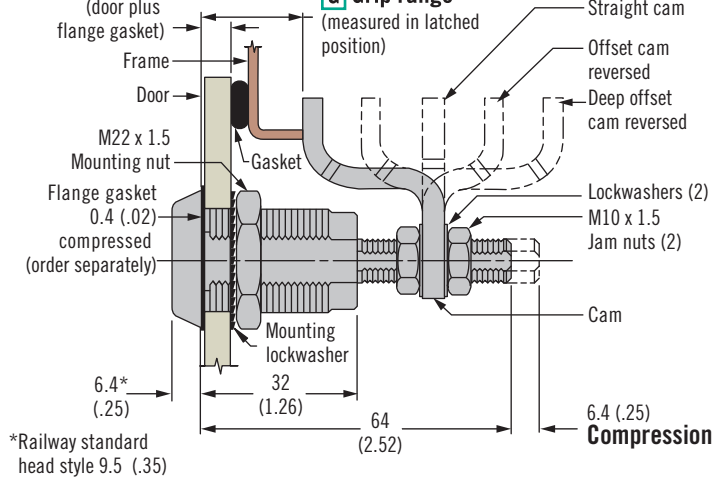

### Railway Standard - Bellcore 216

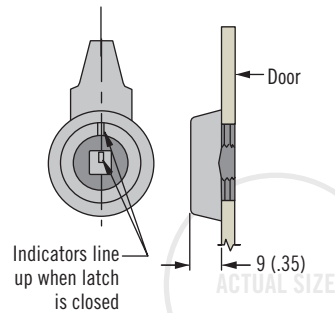

### Other Tool Head Styles

(slotted recess shown)

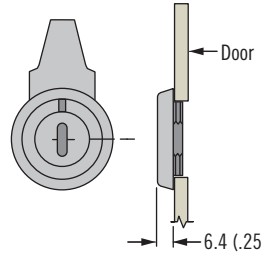

### Knob Style

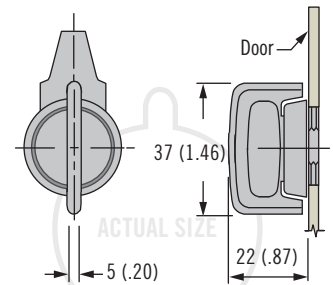

### T-Handle Style

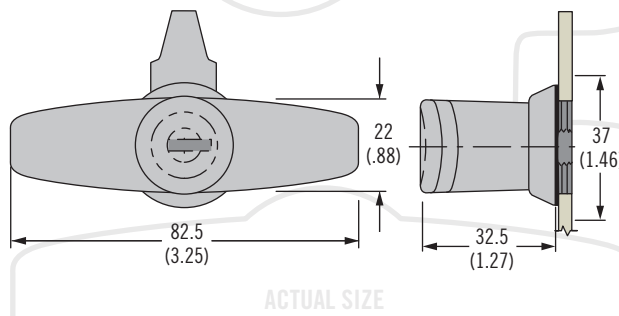

### Wing Knob Style

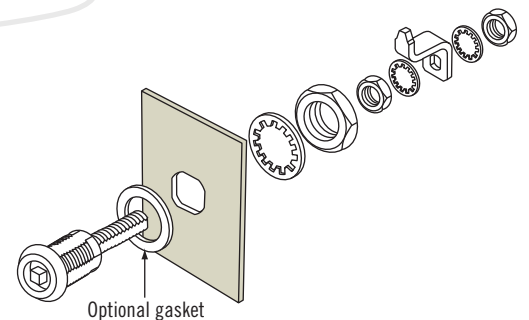
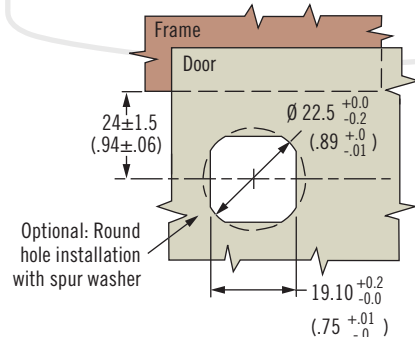
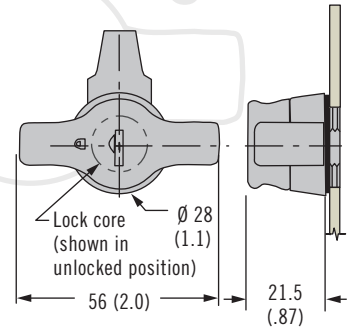

Other options available. For complete details on variety, part numbers, installation and specification, go to



[www.southco.com/E3](http://www.southco.com/E3)

Dimensions in millimeters (inch) unless otherwise stated



**H** Head Styles (other head styles available)

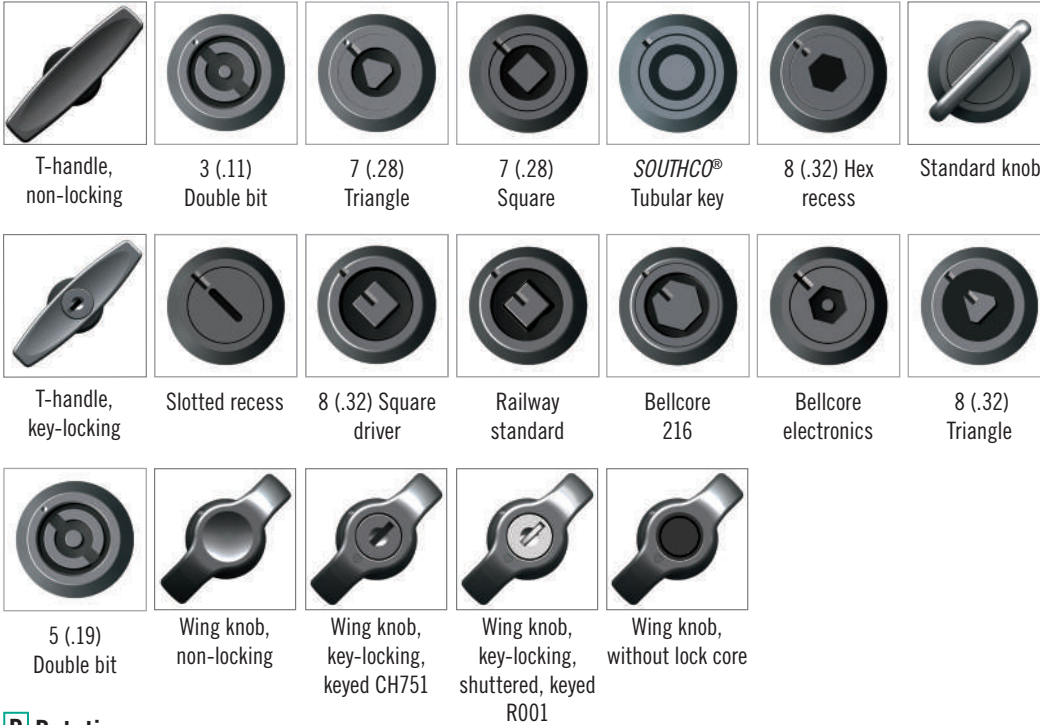

**R** Rotation

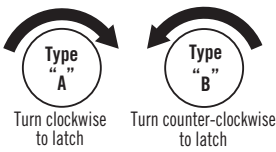

**Part Number Selection**  
See table

**E3 - R H - G F**

**R** Rotation

- 1 Type A clockwise to latch
- 22 Type B counter-clockwise to latch

**H** Head style

- 1 T-handle, non-locking
- 2 3 (.11) Double bit
- 3 7 (.28) Triangle
- 4 7 (.28) Square
- 5 SOUTHCO® Tubular key
- 6 8 (.32) Hex recess
- 7 Standard knob
- 8 T-Handle, key-locking keyed CH751 (two flat keys supplied)
- 9 Slotted recess
- 10 8 (.32) Square driver
- 11 Railway standard
- 15 Bellcore 216
- 16 Bellcore electronics
- 20 8 (.32) Triangle
- 48 5 (.19) Double bit
- 50 Wing knob, non-locking
- 51 Wing knob, key-locking, keyed CH751 (1 overmolded key supplied)
- 58 Wing knob, key-locking, keyed R001 (1 overmolded key supplied)
- 59 Wing knob (no lock)

**F** Finish

- 1 Chrome plated
- 5 Black powder coated
- 7 Silver powder coated

G Grip	Minimum	Maximum	Cam Type
1	11.4 (.45)	27.2 (1.07)	Deep offset cam, forward
	66.3 (2.61)	76.2 (3.00)	Deep offset cam, reversed
2	25.4 (1)	41.1 (1.62)	Offset cam, forward
	52.6 (2.07)	68.3 (2.69)	Offset cam, reversed
3	38.9 (1.53)	54.6 (2.15)	Straight cam





# E3 VISE ACTION® Compression Latch

Zinc and plated steel · Tool or hand operated

Fixed grip · 19.1mm size

- Consistent pre-set compression
- Quick install
- Reduced internal protrusion
- EN 45545-3 E10 Compliant

### Material and Finish

Zinc alloy, powder coated or chrome plated and steel plated

### Performance Details

Maximum static load: 300 N (67 lbf)

### Sealing Notes

NEMA 4 / IP65 sealing is enabled by using optional flange gasket.

Flange gasket part number: E5-17

### Installation Notes

Recommended tightening torque for the mounting nut is 20 N·m (176 in·lbf), and for the mounting screw in 10 N·m (88 in·lbf)

### Keys and Accessories

See page 90

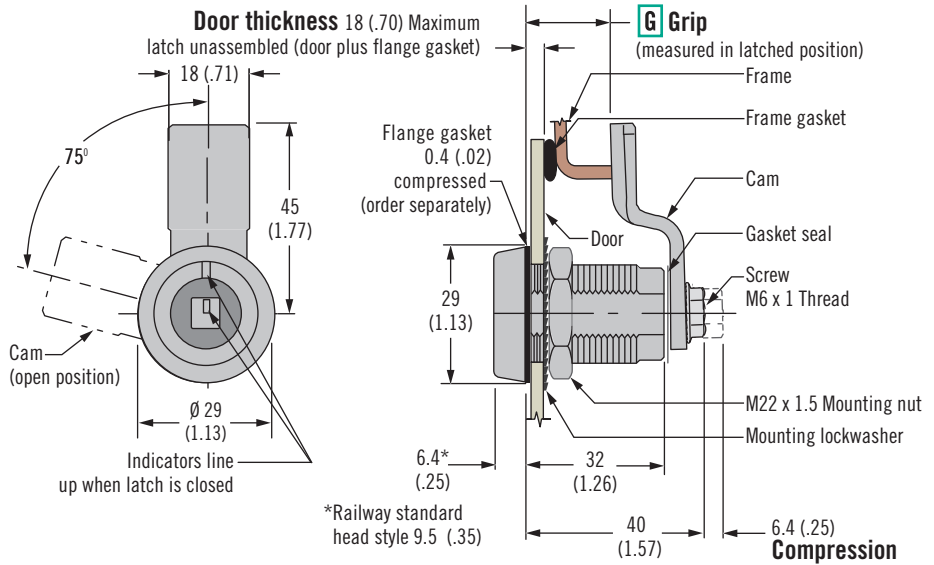

### Railway Standard - Bellcore 216

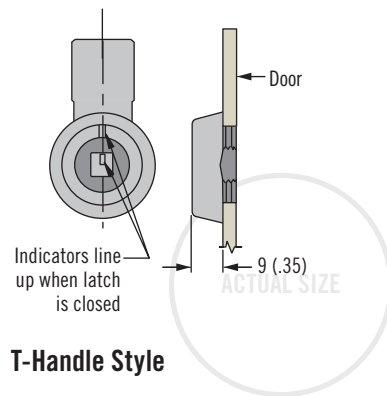

### Other Tool Head Styles (slotted recess shown)

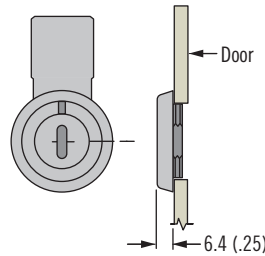

### Knob Style

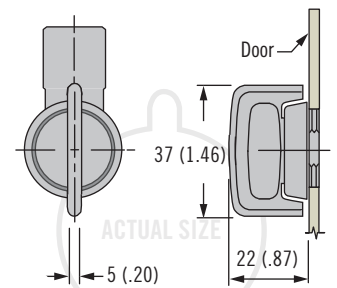

### T-Handle Style

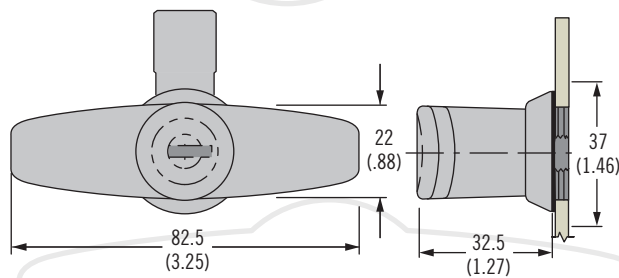

### Wing Knob Style

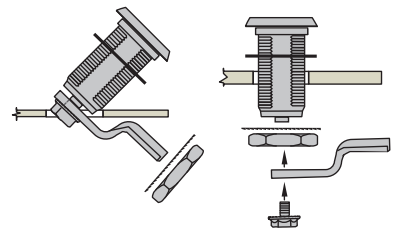
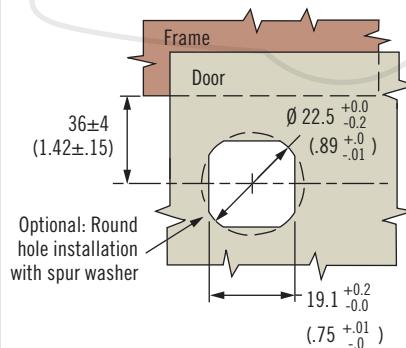
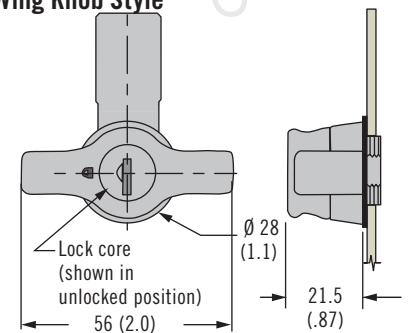

Assembled Installation

Unassembled Installation

Dimensions in millimeters (inch) unless otherwise stated

Other options available. For complete details on variety, part numbers, installation and specification, go to



[www.southco.com/E3](http://www.southco.com/E3)

**H Head Styles** (other head styles available)

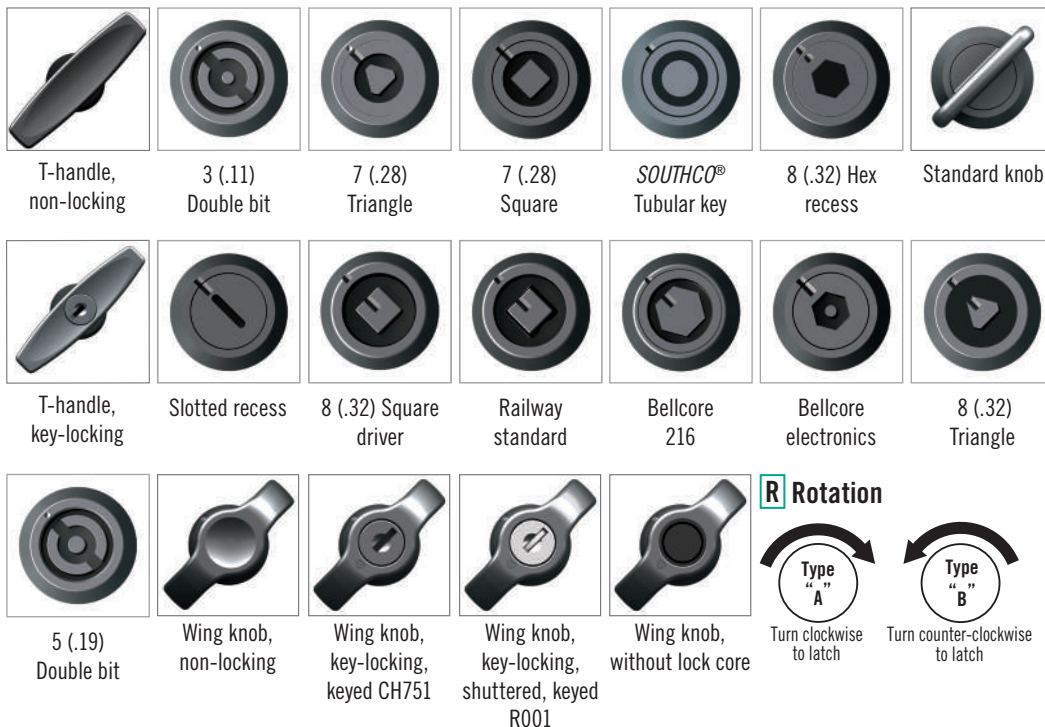

**Part Number Selection**  
See table

**E3 - R H - G F**

- R Rotation**
- 10 Type A clockwise to latch - Latch assembled
  - 12 Type A clockwise to latch - Latch unassembled
  - 27 Type B counter-clockwise to latch - Latch assembled
  - 29 Type B counter-clockwise to latch - Latch unassembled

- F Finish**
- 1 Chrome plated
  - 5 Black powder coated
  - 7 Silver powder coated

- H Head style**
- 1 T-handle, non-locking
  - 2 3 (.11) Double bit
  - 3 7 (.28) Triangle
  - 4 7 (.28) Square
  - 5 SOUTHCO® Tubular key
  - 6 8 (.32) Hex recess
  - 7 Standard knob
  - 8 T-Handle, key-locking keyed CH751 (two flat keys supplied)
  - 9 Slotted recess
  - 10 8 (.32) Square driver
  - 11 Railway standard
  - 15 Bellcore 216
  - 16 Bellcore electronics
  - 20 8 (.32) Triangle
  - 48 5 (.19) Double bit
  - 50 Wing knob, non-locking
  - 51 Wing knob, locking, keyed CH751 (1 overmolded key supplied)
  - 58 Wing knob, locking, keyed R001 (1 overmolded key supplied)
  - 59 Wing knob (no lock)

**G Grip Table**

Total Grip	G	Maximum Door Thickness for Assembled Latch	Total Grip	G	Maximum Door Thickness for Assembled Latch
15 (.59)	00	Use unassembled	35 (1.38)	10	7 (.28)
17 (.67)	01	Use unassembled	37 (1.46)	11	
19 (.75)	02	1 (.04)	39 (1.53)	12	
21 (.83)	03	2 (.08)	41 (1.61)	13	
23 (.91)	04	4 (.16)	43 (1.69)	14	
25 (.98)	05	5 (.20)	45 (1.77)	15	7 (.28)
27 (1.06)	06	6 (.24)	47 (1.85)	16	
29 (1.14)	07	7 (.28)	49 (1.93)	17	
31 (1.22)	08		51 (2.01)	18	
33 (1.30)	09		53 (2.09)	19	



# E3 VISE ACTION® Compression Latch

Zinc and plated steel · Tool or hand operated  
Three hole mount · Adjustable grip · 19.1mm size

- Consistent pre-set compression
- Easy grip adjustment

### Material and Finish

Zinc alloy, powder coated or chrome plated and steel, zinc plated

### Performance Details

Maximum static load:  
450 N (100 lbf)

### Installation Notes

For door thickness greater than 4 (.16) calculate screw length using the following formula:  
Door thickness + 6 (.24)

### Keys and Accessories

See page 90

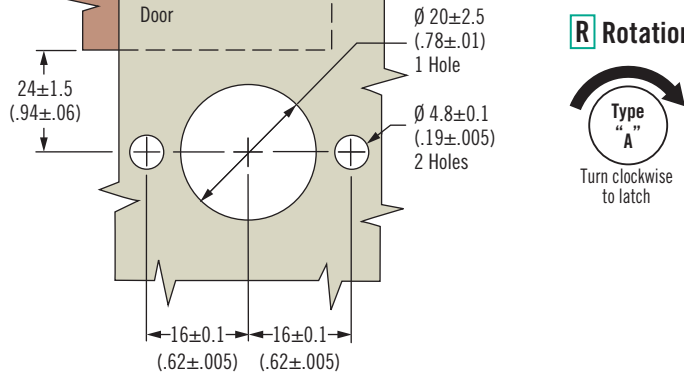
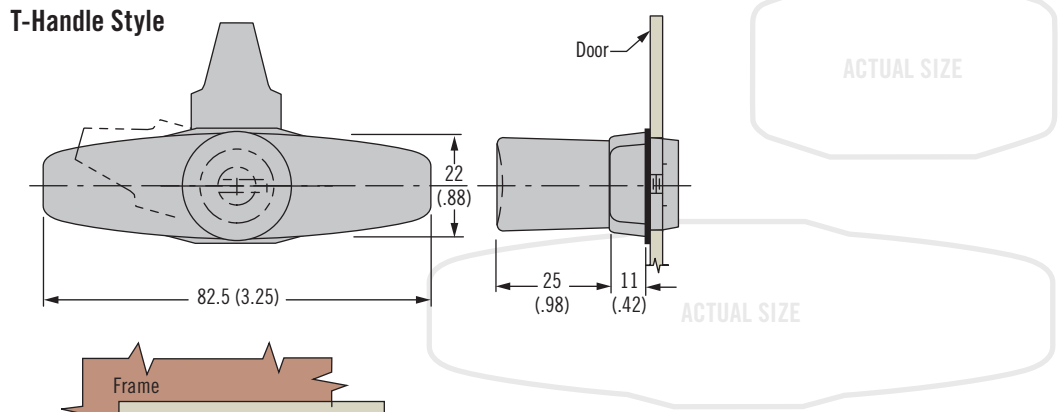
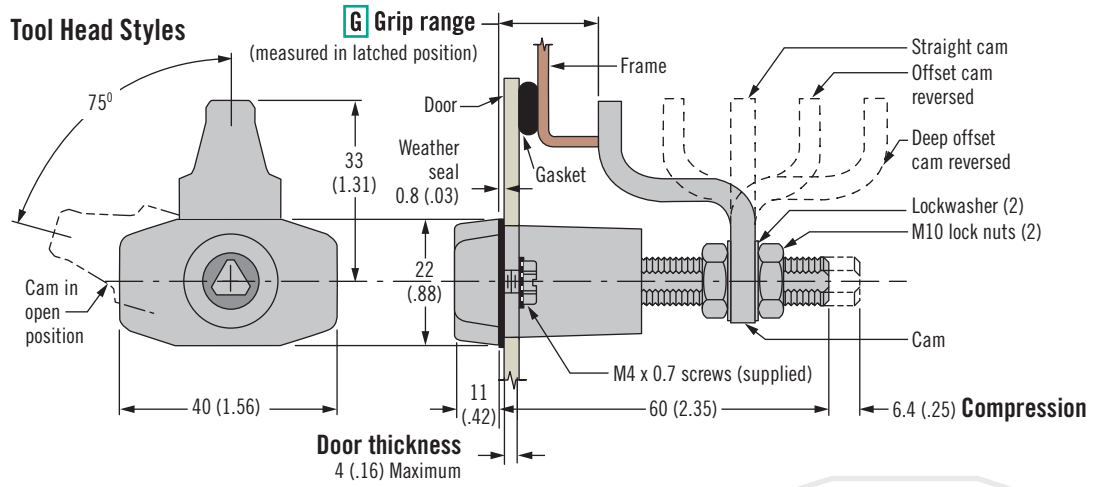

### Part Number Selection

See table

G Grip	Minimum	Maximum	Cam Type
1	7.9 (.31)	23.6 (.93)	Deep offset cam, forward
	62.7 (2.47)	76.2 (3.00)	Deep offset cam, reversed
2	21.8 (.86)	37.3 (1.47)	Offset cam, forward
	49 (1.93)	64.8 (2.55)	Offset cam, reversed
3	35.3 (1.39)	51 (2.00)	Straight cam

### H Head style

- 1 T-handle non-locking
- 2 3 (.11) Double bit
- 3 7 (.28) Triangle
- 4 7 (.28) Square
- 5 SOUTHCO® Tubular key
- 6 8 (.32) Hex recess
- 8 T-Handle locking keyed CH751 (two flat keys supplied)

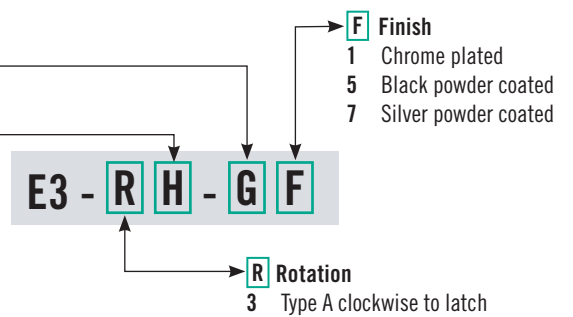



# E3 VISE ACTION® Compression Latch

Aluminum · Tool Operated · Adjustable grip

19.1mm size

- **Light Weight**
- **Premium finish and corrosion resistance**
- **Easy grip adjustment**
- **EN 45545-3 E30 Compliant**

### Material and Finish

Aluminum, Anodized or Powder Coated.

Black hard anodized assembly - Stainless Steel cam and hardware  
All other finishes - Steel cam and hardware

### Performance Details

Maximum static load: 530 N (120 lbf)

Complies with DIN EN 61373 vibration standard

### Sealing Notes

NEMA 4 and IP65 achieved using gasket supplied

### Installation Notes

**Caution:** Position cam so latching function can be achieved comfortably by hand.

Recommended tightening torque for the mounting nut is 20 N·m (176 in·lbf)

Keys and accessories see page 90

### Part Number Selection

See table.

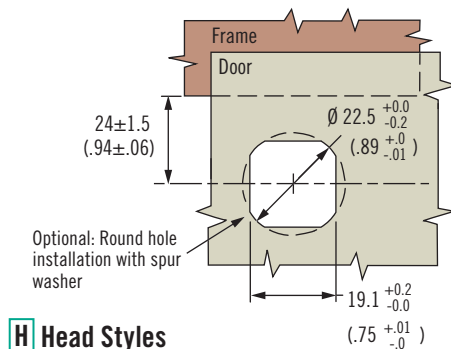
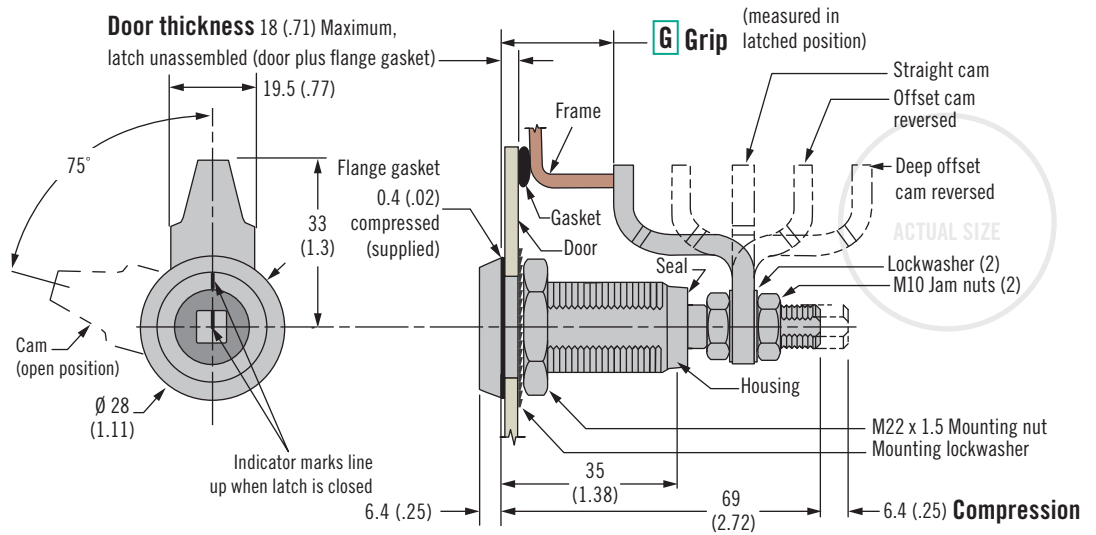

### R Rotation

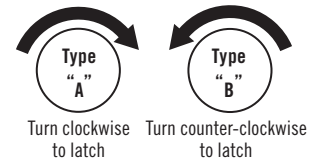

### H Head Styles

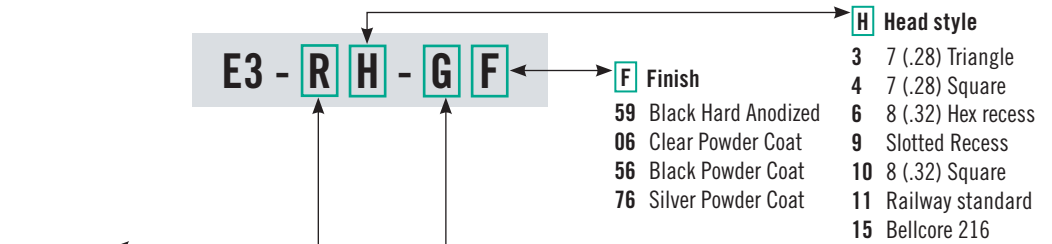

- R Rotation**
- 1 Type A clockwise to latch
  - 22 Type B counter-clockwise to latch

G Grip	Minimum	Maximum	Cam Type
1	16.4 (0.64)	32.2 (1.26)	Deep offset cam, forward
	71.3 (2.80)	81.2 (3.19)	Deep offset cam, reversed
2	30.4 (1.19)	46.1 (1.81)	Offset cam, forward
	57.6 (2.26)	73.3 (2.88)	Offset cam, reversed
3	43.9 (1.72)	59.6 (2.34)	Straight cam



# E3 VISE ACTION® Compression Latch

Aluminum · Tool Operated · Fixed grip  
19.1mm size



- Light Weight
- Premium finish and corrosion resistance
- Reduced internal protrusion
- EN 45545-3 E30 Compliant

### Material and Finish

Aluminum, Anodized or Powder Coated.

Black hard anodized assembly - Stainless Steel cam and hardware  
All other finishes - Steel Cam and hardware

### Performance Details

Maximum static load: 450 N (102 lbf)

Complies with DIN EN 61373 vibration standard

(See [www.southco.com](http://www.southco.com) for details)

### Sealing Notes

NEMA 4 and IP65 achieved using gasket supplied

### Installation Notes

Recommended tightening torque for the mounting nut is 20 N·m (176 in·lbf), and for the mounting screw is 10 N·m (88 in·lbf)

Keys and accessories see page 90

### Part Number Selection

Select grip from table, if your grip is between two options choose smaller.

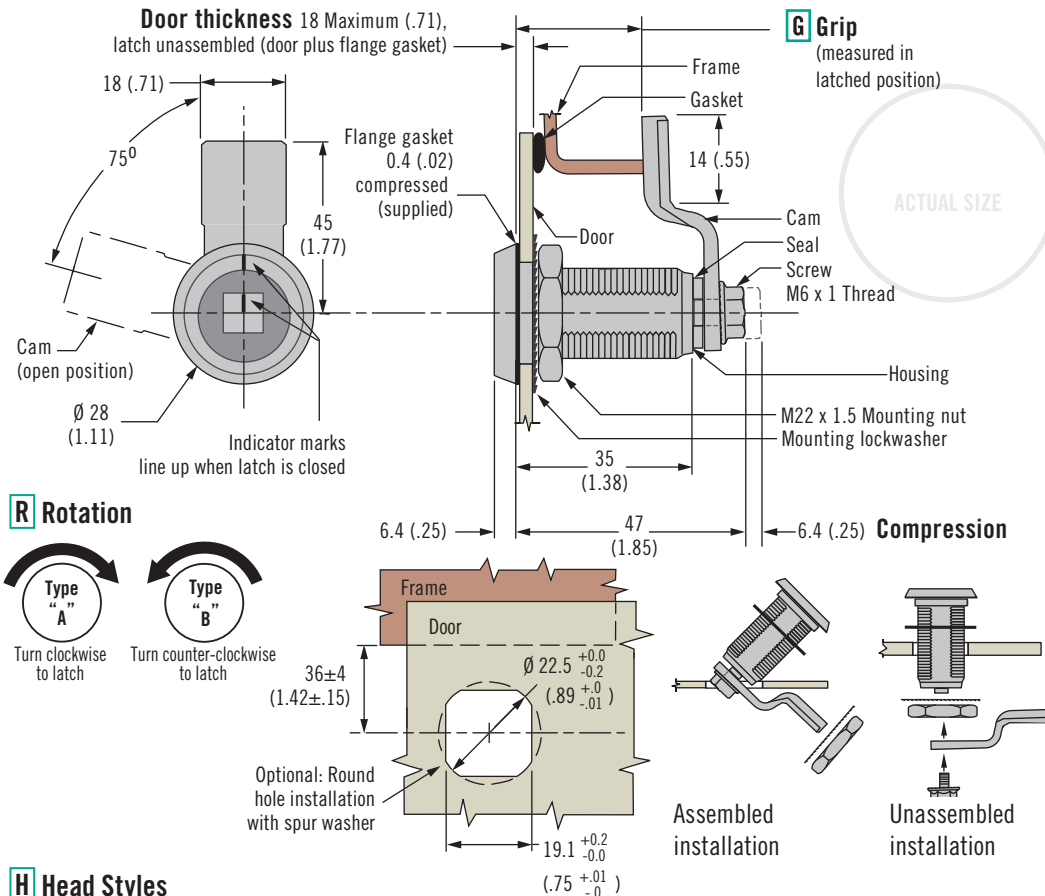

### R Rotation

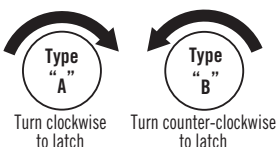

### H Head Styles

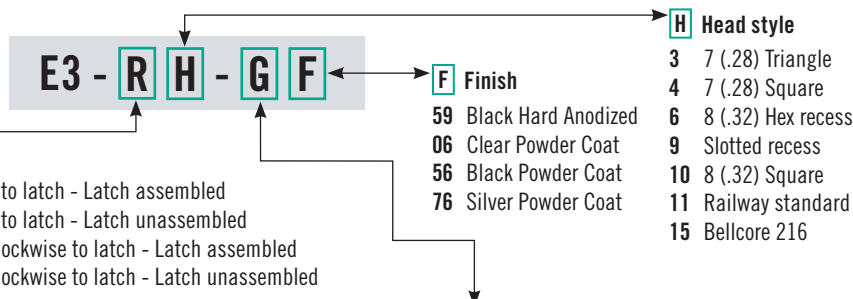
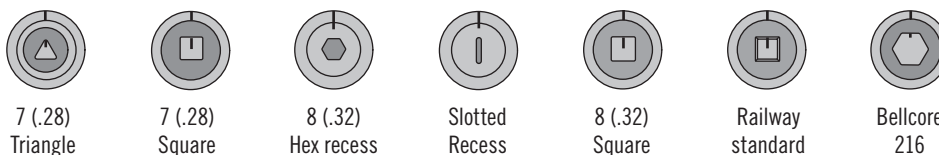

### R Rotation

- 10 Type A clockwise to latch - Latch assembled
- 12 Type A clockwise to latch - Latch unassembled
- 27 Type B counter-clockwise to latch - Latch assembled
- 29 Type B counter-clockwise to latch - Latch unassembled

### H Head style

- 3 7 (.28) Triangle
- 4 7 (.28) Square
- 6 8 (.32) Hex recess
- 9 Slotted recess
- 10 8 (.32) Square
- 11 Railway standard
- 15 Bellcore 216

### F Finish

- 59 Black Hard Anodized
- 06 Clear Powder Coat
- 56 Black Powder Coat
- 76 Silver Powder Coat

### G Grip Table

Total Grip	G	Max. Door Thickness for Assembled Latch	Total Grip	G	Max. Door Thickness for Assembled Latch	Total Grip	G	Max. Door Thickness for Assembled Latch	Total Grip	G	Max. Door Thickness for Assembled Latch
20 (.79)	00	1 (.04)	30 (1.18)	05	7 (.28)	40 (1.57)	10	7 (.28)	50 (1.97)	15	7 (.28)
22 (.87)	01	2 (.08)	32.5 (1.28)	06		42 (1.65)	11		52 (2.05)	16	
24 (.94)	02	4 (.16)	34 (1.34)	07		44 (1.73)	12		54 (2.13)	17	
26 (1.02)	03	5 (.20)	36 (1.42)	08		46 (1.81)	13		56 (2.20)	18	
28 (1.10)	04	6 (.24)	38 (1.50)	09		48 (1.89)	14		58 (2.28)	19	







# E3 VISE ACTION® Compression Latch

Machined stainless steel housing · Tool operated  
Adjustable grip · 19.1mm size · Compact

- Minimal panel intrusion
- Consistent pre-set compression
- Easy grip adjustment
- Premium finish and corrosion resistance
- EN 45545-3 E60 Compliant

### Material and Finish

Stainless steel  
(304 and 316 machined)

### Performance Details

Maximum static load:  
600 N (136 lbf)

### Sealing Notes

NEMA 4 and IP65 enabled using  
gasket supplied

### Keys and Accessories

See page 90

### Installation Notes

**Caution:** Position cam so latching  
function can be achieved  
comfortably by hand.  
Recommended tightening torque  
for the mounting nut is 20 N·m  
(176 in·lbf).

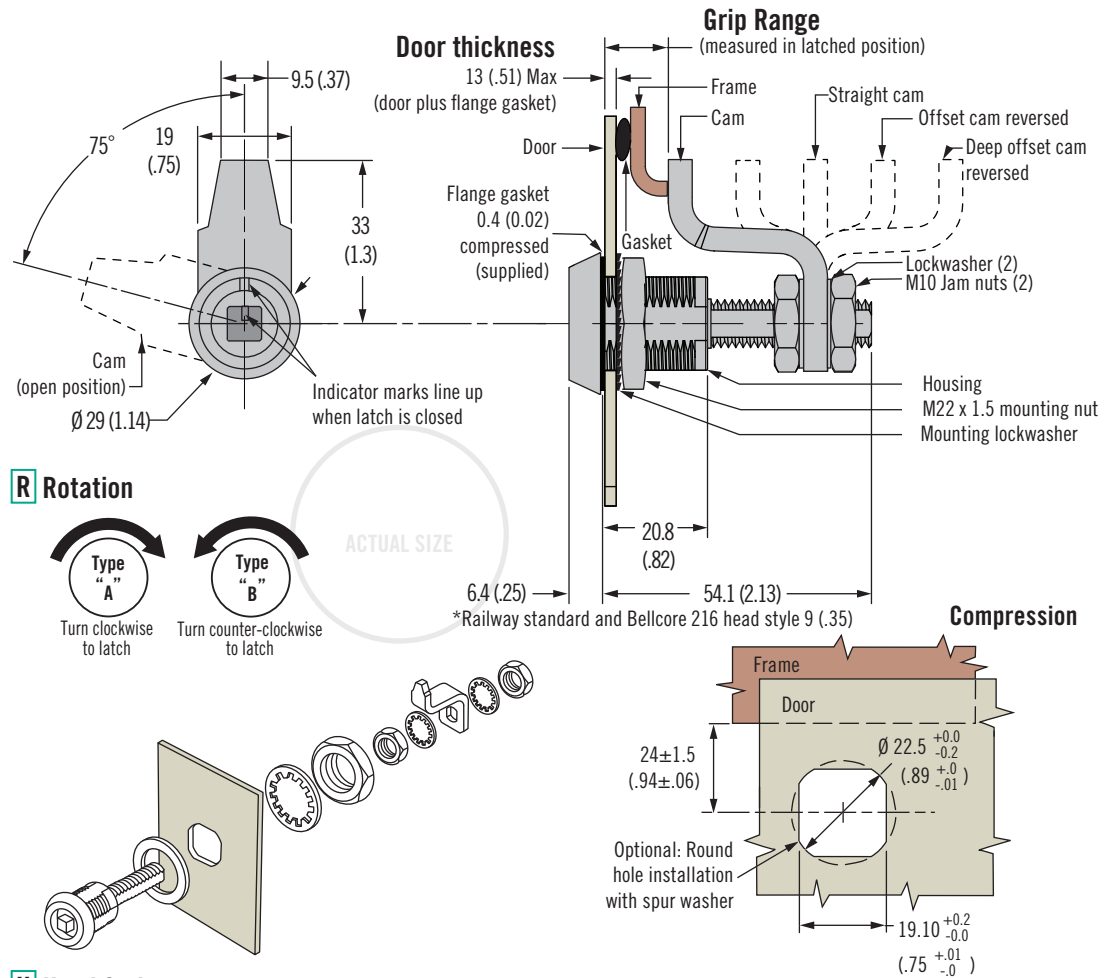

### H Head Styles

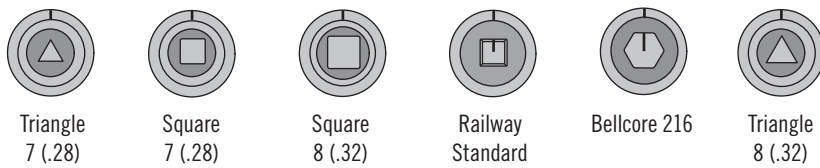

### Part Number Selection

See table  
Order latch and cam separately

### Latch Part Number (no cam)

- H** Head Style ←
- 3 7 (.28) Triangle
  - 4 7 (.28) Square
  - 10 8 (.32) Square
  - 11 Railway standard
  - 15 Bellcore 216
  - 20 8 (.32) Triangle

**E3 - C R H - 00**

- R** Rotation ←
- 1 Type A clockwise to latch
  - 22 Type B counter-clockwise to latch

Cam Part Number Table (order separately from latch)			
Minimum Grip	Maximum Grip	Cam Type	Part Number
3.3 (.13)	19 (.75)	Deep offset cam, forward	E3-28-201-24
58.6 (2.31)	66.5 (2.62)	Deep offset cam, reversed	
17 (.67)	32.7 (1.29)	Offset cam, forward	E3-28-202-24
44.4 (1.75)	60.1 (2.37)	Offset cam, reversed	
30.7 (1.21)	46.4 (1.83)	Straight cam	E3-28-203-24

Dimensions in millimeters (inch) unless otherwise stated

# E3 VISE ACTION® Compression Latch

Machined stainless steel housing · Tool operated

Fixed grip · 19.1mm size · Compact



89B

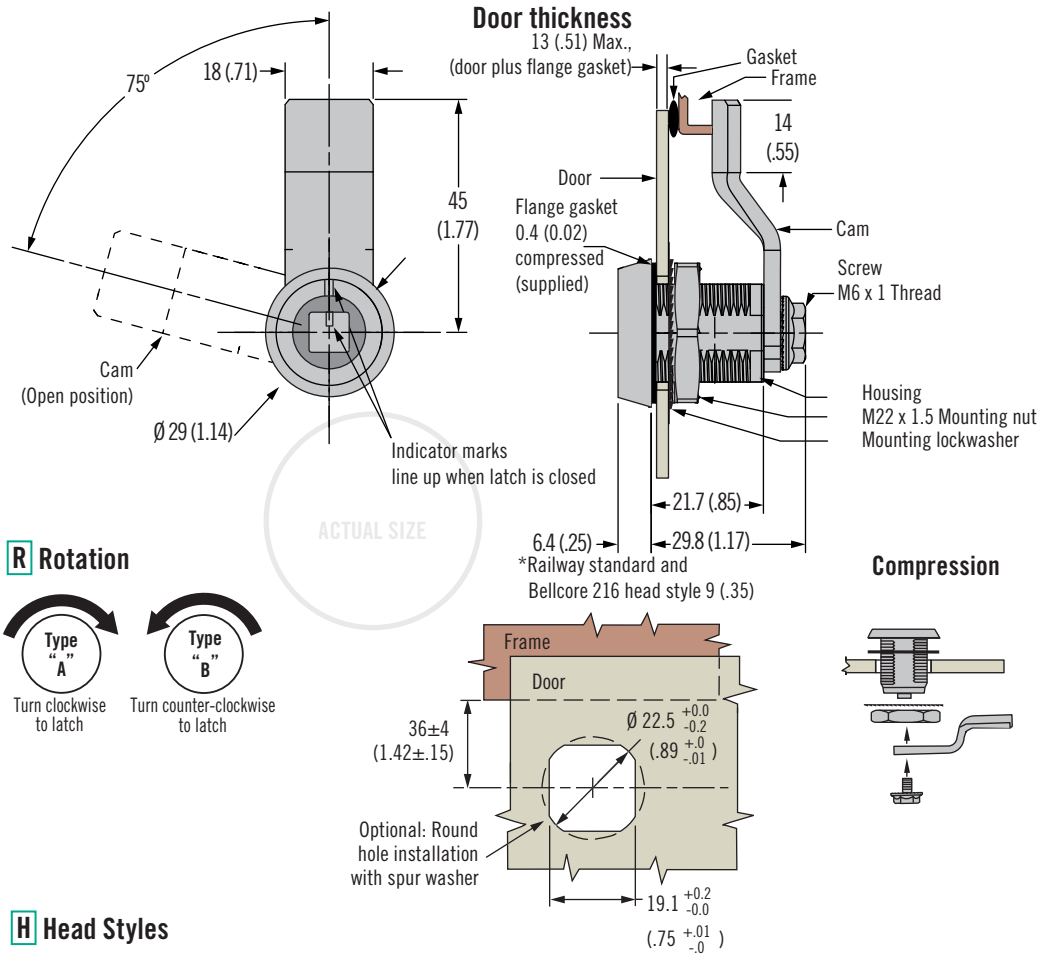

- Minimal panel intrusion
- Consistent pre-set compression
- Premium finish and corrosion resistance
- EN 45545-3 E60 Compliant

## Material and Finish

Stainless steel (304 and 316 machined)

## Performance Details

Maximum static load:  
450 N (100 lbf)

## Sealing Notes

NEMA 4 and IP65 enabled using gasket supplied

## Keys and Accessories

See page 90

## Installation Notes

Recommended tightening torque for the mounting nut is 20 N·m (176 in·lbf), and for the mounting screw is 10 N·m (88 in·lbf)

## H Head Styles

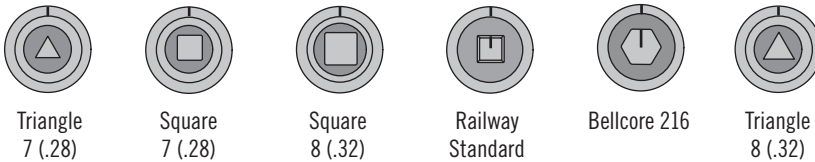

## Part Number Selection

See table

Order latch and cam separately.

Select grip from Cam table if your grip is between two options choose the smaller grip

Latch Part Number (no cam)

**E3 - C R H - UUO**

### R Rotation

- 12 Type A clockwise to latch
- 29 Type B counter-clockwise to latch

### H Head style

- 3 7 (.28) Triangle
- 4 7 (.28) Square
- 10 8 (.32) Square
- 11 Railway standard
- 15 Bellcore 216
- 20 8 (.32) Triangle

## Cam Part Number (order separately from latch)

Grip	Part Number	Grip	Part Number	Grip	Part Number	Grip	Part Number
4 (.16)	E3-28-700-24	14 (.55)	E3-28-705-24	24 (.94)	E3-28-710-24	34 (1.34)	E3-28-715-24
6 (.31)	E3-28-701-24	16 (.63)	E3-28-706-24	26 (1.02)	E3-28-711-24	36 (1.42)	E3-28-716-24
8 (.31)	E3-28-702-24	18 (.71)	E3-28-707-24	28 (1.10)	E3-28-712-24	38 (1.50)	E3-28-717-24
10 (.39)	E3-28-703-24	20 (.79)	E3-28-708-24	30 (1.18)	E3-28-713-24	40 (1.57)	E3-28-718-24
12 (.47)	E3-28-704-24	22 (.87)	E3-28-709-24	32 (1.26)	E3-28-714-24	42 (1.65)	E3-28-719-24



# E3 VISE ACTION® Compression Latch

Zinc and plated steel housing · Tool operated  
Adjustable grip · 19.1mm size · Compact

- Minimal panel intrusion
- Consistent pre-set compression
- Easy grip adjustment
- Tool operated for security
- EN 45545-3 E10 Compliant

### Material and Finish

Zinc alloy, powder coated or chrome plated and steel, zinc plated

### Performance Details

Maximum static load:  
450 N (100 lbf)

### Sealing Notes

NEMA 4 and IP65 enabled using gasket supplied

### Keys and Accessories

See page 90

### Installation Notes

**Caution:** Position cam so latching function can be achieved comfortably by hand.  
Recommended tightening torque for the mounting nut is 20 N·m (176 in·lbf).

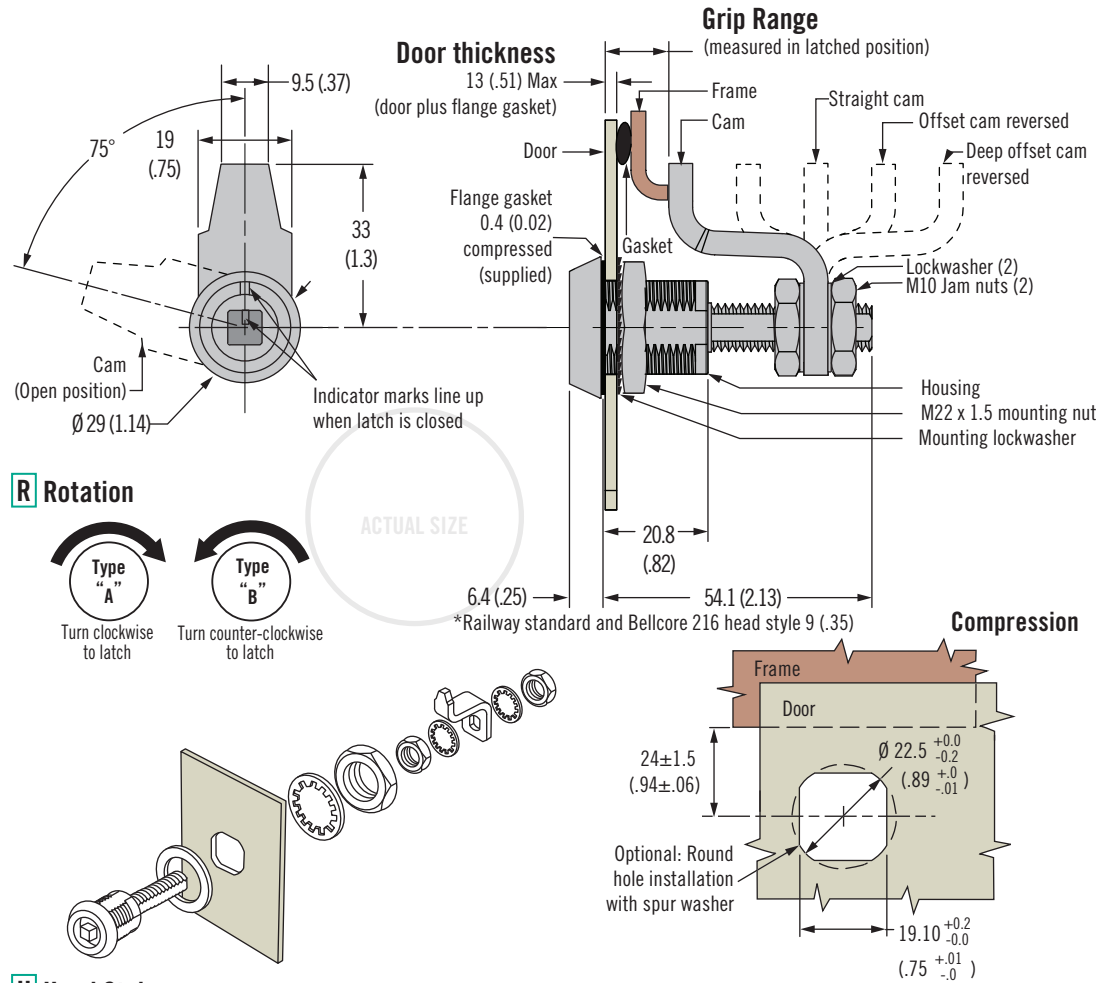

### Rotation

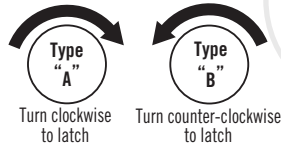

### Head Styles

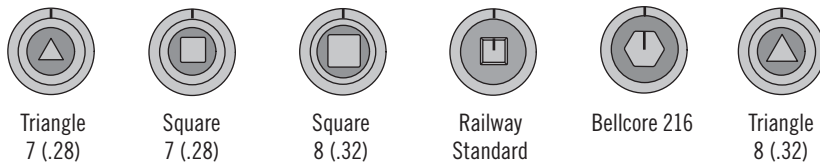

### Part Number Selection

See table  
Order latch and cam separately

### Latch Part Number (no cam)

**E3 - C R H - O F**

- R** Rotation  
1 Type A clockwise to latch  
22 Type B counter-clockwise to latch
- H** Head Style  
3 7 (.28) Triangle  
4 7 (.28) Square  
10 8 (.32) Square  
11 Railway standard
- F** Finish  
1 Chrome plated  
5 Black powder coated  
7 Silver powder coated
- 15 Bellcore 216  
20 8 (.32) Triangle

Cam Part Number Table (order separately from latch)			
Minimum Grip	Maximum Grip	Part Number	Cam Type
3.3 (.13)	19 (.75)	Deep offset cam, forward	E3-28-201-12
58.6 (2.31)	66.5 (2.62)	Deep offset cam, reversed	
17 (.67)	32.7 (1.29)	Offset cam, forward	E3-28-202-12
44.4 (1.75)	60.1 (2.37)	Offset cam, reversed	
30.7 (1.21)	46.4 (1.83)	Straight cam	E3-28-203-12

Dimensions in millimeters (inch) unless otherwise stated

# E3 VISE ACTION® Compression Latch

Zinc and plated steel housing · Tool operated

Fixed grip · 19.1mm size · Compact



89D

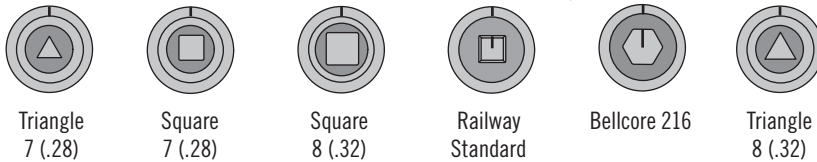
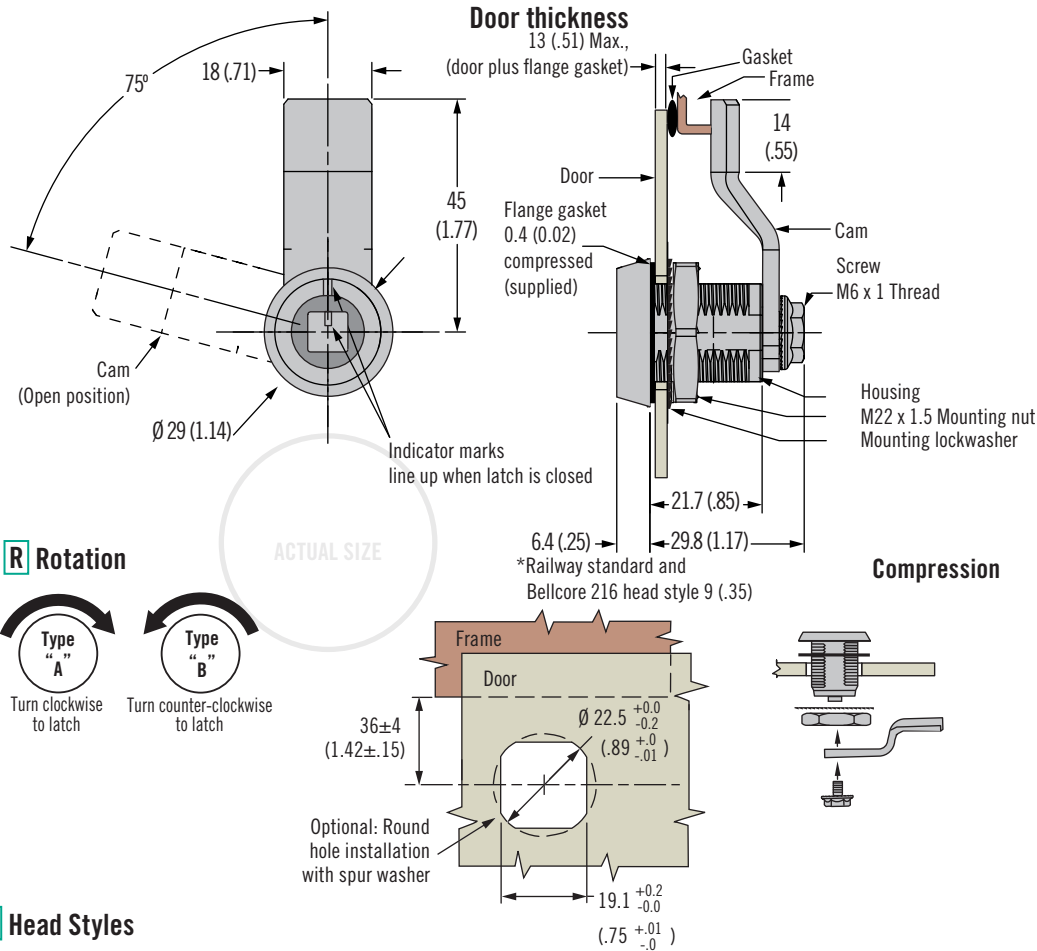

Latch Part Number (no cam)

**E3 - C R H - UU F**

**R Rotation**

- 12 Type A clockwise to latch
- 29 Type B counter-clockwise to latch

**H Head style**

- 3 7 (.28) Triangle
- 4 7 (.28) Square
- 10 8 (.32) Square

- 11 Railway standard
- 15 Bellcore 216
- 20 8 (.32) Triangle

**F Finish**

- 1 Chrome plated
- 5 Black powder coated
- 7 Silver powder coated

**Cam Part Number (order separately from latch)**

Grip	Part Number	Grip	Part Number	Grip	Part Number	Grip	Part Number
4 (.16)	E5-2500	14 (.55)	E5-2505	24 (.94)	E5-2510	34 (1.34)	E5-2515
6 (.31)	E5-2501	16 (.63)	E5-2506	26 (1.02)	E5-2511	36 (1.42)	E5-2516
8 (.31)	E5-2502	18 (.71)	E5-2507	28 (1.10)	E5-2512	38 (1.50)	E5-2517
10 (.39)	E5-2503	20 (.79)	E5-2508	30 (1.18)	E5-2513	40 (1.57)	E5-2518
12 (.47)	E5-2504	22 (.87)	E5-2509	32 (1.26)	E5-2514	42 (1.65)	E5-2519

- Minimal panel intrusion
- Consistent pre-set compression
- Tool operated for security
- EN 45545-3 E10 Compliant

**Material and Finish**

Zinc alloy, powder coated or chrome plated and steel, zinc plated

**Performance Details**

Maximum static load:  
300 N (67 lbf)

**Sealing Notes**

NEMA 4 and IP65 enabled using gasket supplied

**Keys and Accessories**

See page 90

**Installation Notes**

Recommended tightening torque for the mounting nut is 20 N·m (176 in·lbf), and for the mounting screw is 10 N·m (88 in·lbf)

**Part Number Selection**

See table

Order latch and cam separately.

Select grip from Cam table if your grip is between two options choose the smaller grip



# E3 VISE ACTION® Compression Latch Accessories

## Keys

### Material and Finish

Tool Operated: Zinc, bright nickel plate or natural and nylon, black  
 Tubular: Steel, bright nickel plate

### Notes

\*Does not work with 7mm tapered triangle driver

### Tool Operated Key



- F** Finish
- 1 Plated zinc
  - 2 Natural zinc
  - 3 Nylon black

**E3 - H - F**

### H Head style

2	3	4	7	8
3 (.11) Double bit	7 (.28) Triangle	7 (.28) Square	8 (.32) Triangle	8 (.32) Square recess
9	10	11	12	14
5 (.19) Double bit	8 (.32) Square male	Bellcore electronics	Bellcore 216	Railway Standard
15	16	17	5	E3-26-819-15
Railway male	7 (.28) Tapered triangle	17 (.67) square	Southco® Tubular 19.1 (.75)	Southco® Tubular 13.5 (.65)

### Southco® Tubular Key

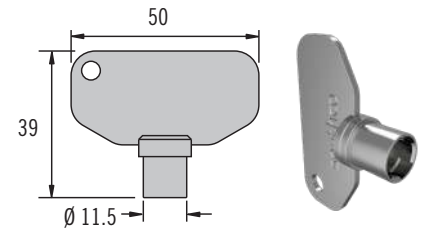

### Part Number

Overmolded key CH751:

Single: PK-10-10-05

Pair: PK-10-01-05

Overmolded key R001:

Single: PK-10-10-05-KR001

Pair: PK-10-01-05-KR001

Flat key

Pair: PK-10-01

### Overmolded Keys

Key CH751  
PK-10-10-05

Key R001  
PK-10-10-05-KR001



### Flat Keys

Key CH751  
PK-10-01



# E3 VISE ACTION® Compression Latch Accessories

## Fixed mounting bracket and cup



### Flush Mounting Bracket

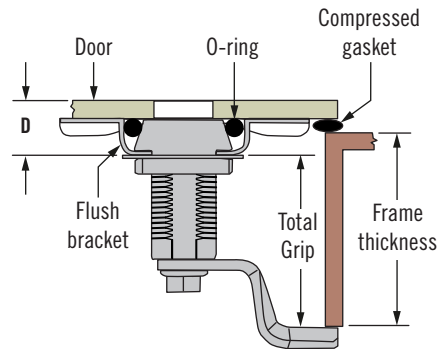
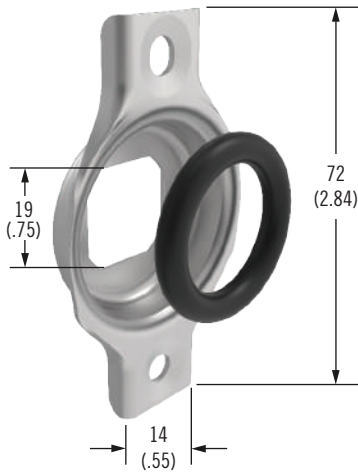

To calculate the **Total Grip**, subtract cup depth (**D**) from **frame thickness + compressed gasket**

**E3 - 77 - 25** **D** - **M**

**D** Depth

- 1 6.6 mm (for tool head style)
- 2 9.3 mm (for Railway standard or Bellcore 216 head style only)

**M** Material

- 12 Galvanized steel
- 24 Stainless steel 304

### Material and Finish

Stainless steel or galvanized steel with rubber o-ring

### Sealing Notes

Environmental sealing is achieved by using latch with flange gasket and sealing the mounting screw threads.

### Notes

For use with 19.1mm size single hole mount tool operated E3 VISE ACTION® compression latches

### Flush Cup

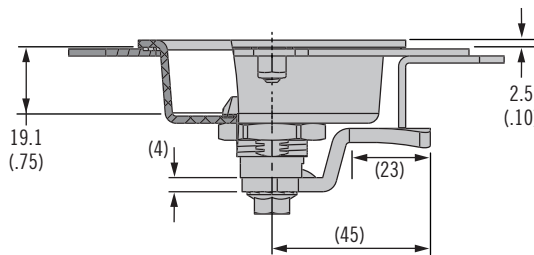
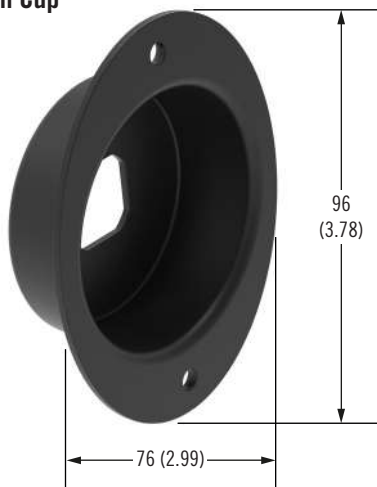

To calculate total grip, add cup depth (**D**) to latch grip

**E5 - 2** **M** - 61 **D** - 5

**M** Mounting Style

- 0 M5 studs
- 1 Through hole

**D** Depth

- 1 19 mm (for wingknob head style)
- 2 4 mm (for tool head style)

### Material and Finish

Carbon steel, black powder coated





# E3 VISE ACTION® Compression Latch Accessories

Sealing & spur washers · Sealing covers

### Material and Finish

Sealing washers: Neoprene, natural  
Spur washer: Steel, zinc plated

### Notes

Spur washer provides for round hole installation in wood and similar materials of low density

### Adjustment Formula

Sealing washer : add 0.4 (.02) to door thickness  
Spur washer : add 0.8 (.03) to door thickness

### Material and Finish

Sealing cover: Thermoplastic elastomer, black

### Notes

Thermoplastic sealing cover cannot be used with Railway standard or Bellcore 216 styles

### Adjustment Formula

Sealing cover : add 2.3 (.09) to door thickness

### Material and Finish

Sealing cover: Stainless steel, electropolished

### Notes

Bi-Stable sealing cover can only be used with tool head styles

### Adjustment Formula

Sealing cover : add 2.0 (.08) to door thickness

### Sealing Washers

13.5mm size

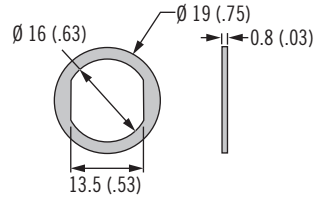

19.1mm size

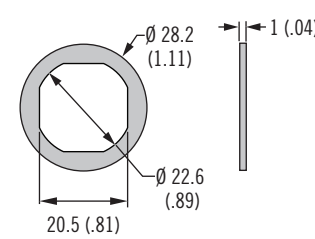

### Spur Washer

19.1mm size

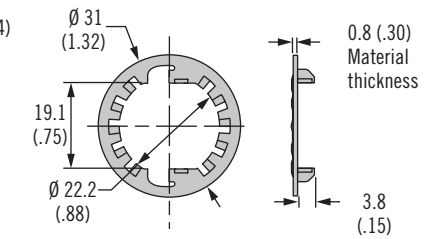

Type	Part Number
Sealing washer 13.5mm size	E3-0-30268-02
Sealing washer 19.1mm size	E5-17

Type	Part Number
Spur washer 19.1mm size	90-6-875

### Sealing Cover

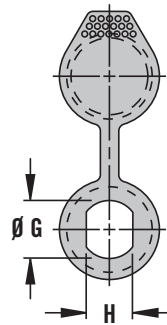
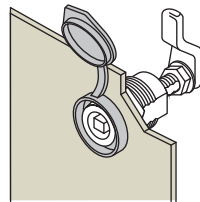
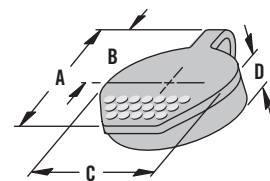

Latch Installation Hole Size		Dimensions			
Ø G	F	A	B	Ø C	D
16 (.63)	13.5 (.53)	40 (1.58)	20 (.85)	29 (1.13)	10.5 (.42)
22.5 (.88)	19.6 (.77)	47 (1.84)	28 (1.09)	35 (1.38)	11.7 (.46)

Type	Part Number
Sealing cover 13.5mm size	90-1
Sealing cover 19.1mm size	90-3

### Bi-Stable Sealing Cover – Stainless Steel



Cover in open position

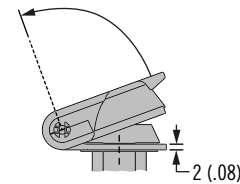
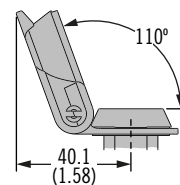

Cover returns to open position

Cover in closed position

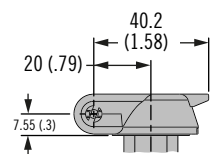

Type	Part Number
B-Stable sealing cover 19.1mm size	E3-80-252-40

# E3 VISE ACTION® Compression Latch Accessories

## Padlock brackets · Finger pulls · Sleeve nuts



### Padlock Bracket (Square)

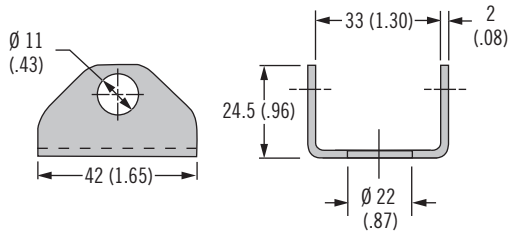

### Padlock Bracket (Round)

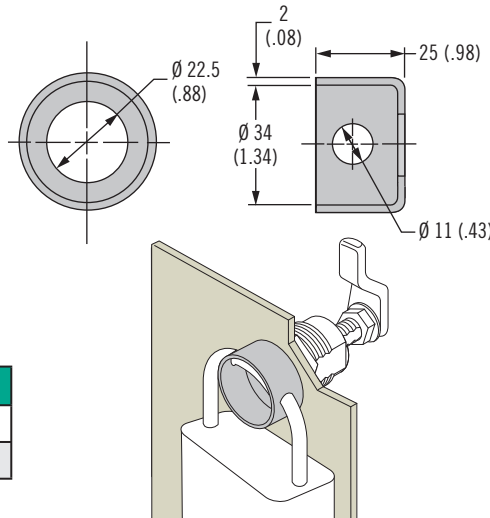

Type	Part Number
Padlock bracket square	E3-77-101-31
Padlock bracket round	E3-77-102-31

### Material and Finish

Stainless steel, black powder coated

### Sealing Notes

To provide sealing use two flange gaskets and add compressed thickness of each flange gasket and bracket thickness to your door thickness.

### Notes

Padlock bracket: For 19.1mm size single hole mount tool operated only  
Only unassembled styles can be used with round padlock bracket

### Notes

Add 2.0 (.08) to door thickness

### Pull Tab (13.5mm size)

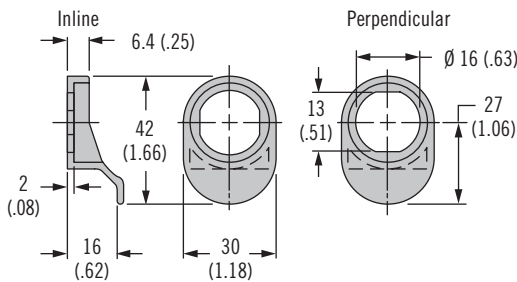

### Pull Tab (19.1mm size)

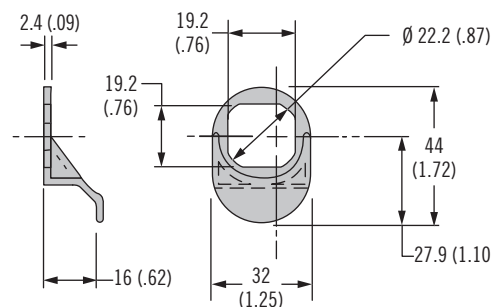

Type	Part Number
Pull tab 13.5 mm size – In-line	E3-27-61
Pull tab 13.5 mm size – Perpendicular	E3-27-62
Pull tab 19.1 mm size	E3-27-1

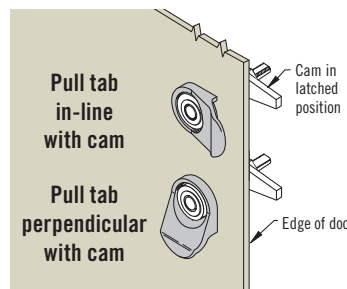

### Material and Finish

Nylon, black

### Adjustment Formula

Add 2.0 (.08) to door thickness

### Sleeve Nut M22 Thread (for 19.1mm size E3 only)

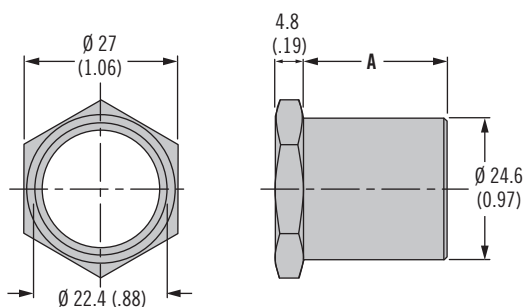

Type	A	Part Number
Sleeve Nut – short	12.7 (.50)	E3-34-263-36
Sleeve Nut - long	25 (.98)	E3-34-264-36

### Material and Finish

Zinc alloy

### Installation Notes

For use in double skin doors.  
Product standard panel cutout in outer door and for the inner door produce 25 (.98) hole for sleeve nut

# Southco® Compression Latches

## Vise Action Series, Flush Design

- Single-hole mount, large size
- Latch provides completely flush outer surface
- Designed for use in thicker panels such as wood
- Seven tool- or key-operated access styles

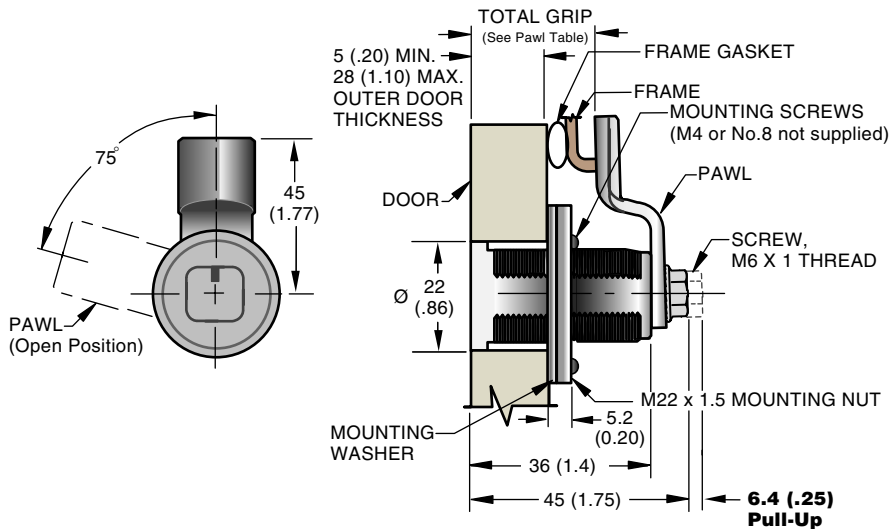

### Pawl Detail

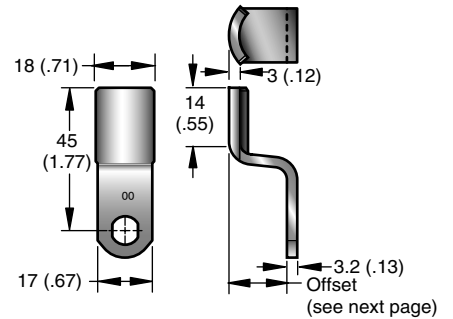

### Mounting Washer

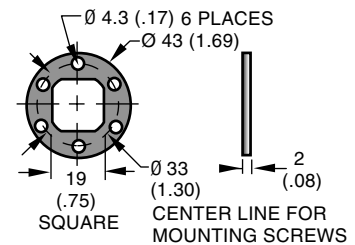

### Mounting Nut

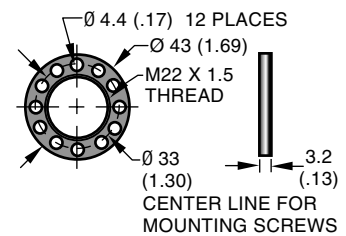

### Key (Order Separately)

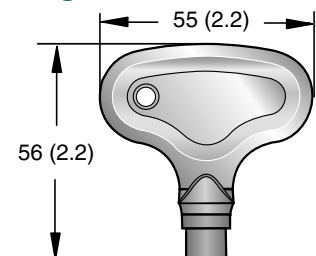

### To determine the proper part number:

1. Choose a head style and finish (see table).
2. Determine the total grip by adding the following items together:
  - Outer door thickness
  - Compressed Frame Gasket
  - Frame thickness
3. Find your total grip in the pawl table. If your grip is between two choices, use the smaller one.
4. Use the 2 digit pawl type code that corresponds to your grip and outer door thickness to complete your latch assembly part number.

HEAD STYLE	8 mm Hex Recess	7 mm Triangle	7 mm Square	8 mm Square Driver	10 mm Hex	Railway Standard	8 mm Triangle
<b>Bright Chrome</b>	—	E3-143-XX1•	E3-144-XX1•	E3-1410-XX1•	E3-1418-XX1•	E3-1411-XX1•	E3-1420-XX1•
<b>Black Powder Coated</b>	E3-146-XX5	E3-143-XX5•	E3-144-XX5•	E3-1410-XX5•	E3-1418-XX5•	E3-1411-XX5•	E3-1420-XX5•
<b>Satin Silver Polyester Powder Coated</b>	E3-146-XX7	E3-143-XX7•	E3-144-XX7•	E3-1410-XX7•	E3-1418-XX7•	E3-1411-XX7•	E3-1420-XX7•
<b>Keys</b>	—	E3-3-1 •	E3-4-1 •	E3-8-1 •	10 mm (.375) Hex Recess (Not available from Southco)	RIC Standard (European Railway Standard) Not available from Southco	E3-7-1 •

Latches are individually packaged. For layer packaged latches (50 pieces minimum, sold in multiples of 50) add -13 to the part number. Example: E3-1410-XX1-13.

## PAWL TYPE NUMBERS

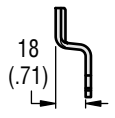
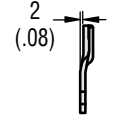
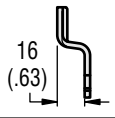
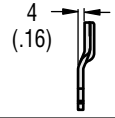
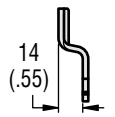
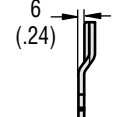
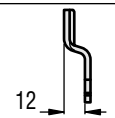
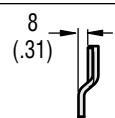
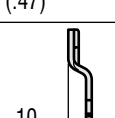
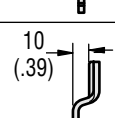
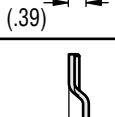
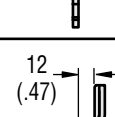
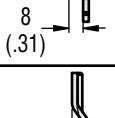
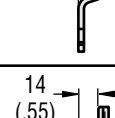
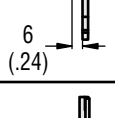
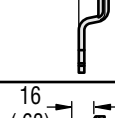
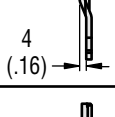
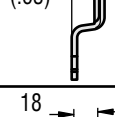
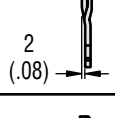
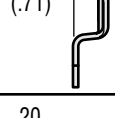
Pawl Type	TOTAL GRIP	Pawl Offset	Pawl Type	TOTAL GRIP	Pawl Offset
XX=00 •	19 (.75)		XX=10 •	39 (1.53)	
XX=01 •	21 (.83)		XX=11 •	41 (1.61)	
XX=02 •	23 (.91)		XX=12 •	43 (1.69)	
XX=03 •	25 (.98)		XX=13 •	45 (1.77)	
XX=04 •	27 (1.06)		XX=14	47 (1.85)	
XX=05 •	29 (1.14)		XX=15	49 (1.93)	
XX=06 •	31 (1.22)		XX=16	51 (2.01)	
XX=07 •	33 (1.30)		XX=17	53 (2.09)	
XX=08 •	35 (1.38)		XX=18	55 (2.17)	
XX=09 •	37 (1.46)		XX=19	57 (2.24)	



### Material and Finish

HOUSING and CAP: Die-cast zinc, bright chrome plated or powder coated, see table. RETAINER and SPRING: 302 Stainless steel, natural. O-RING: Buna-N rubber, natural. CAM and SLEEVE: 1075 Case hardened steel, zinc immersion coating. SHAFT and SCREW: Low carbon steel, zinc plate, chromate plus sealer. PIN: 1008 Steel, zinc plated plus chromate dip. MOUNTING WASHER, MOUNTING NUT and PAWL: 1010 steel, zinc plate, chromate plus sealer.

### Product Strength Guidelines

(To assist in your product selection; samples are available for your evaluation.)

Maximum static load: 300 N (79 lbs.)  
Average ultimate load: 700 N (157 lbs.)

**These loads apply to latch assemblies only. Retention to the panel is subject to user method of installation and material.**

### Panel Preparation

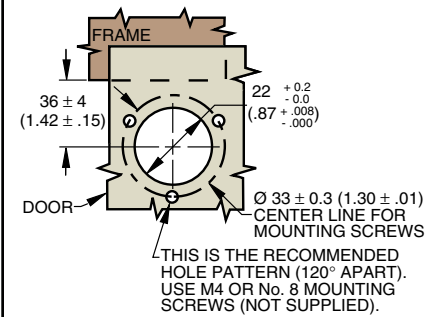

### Installation

1. Insert the latch through the rear of the door. Place the mounting washer then the mounting nut onto the latch.
2. Adjust mounting nut so that the head of the latch is flush with the outside of the door. The holes in the washer and the nut must be aligned. The latch must be aligned to the latching position. Southco recommends using a minimum of three mounting screws in a pattern as shown above.
3. Place pawl on latch shaft and tighten pawl mounting screw while holding the pawl with a 17 (.67) wrench.

Recommended tightening torque for the Pawl Mounting Screw is 10 N•m (88.5 in-lbs).

millimeter (inch)  
millimeter  
(inch)

Dimensions without tolerances are for reference only.

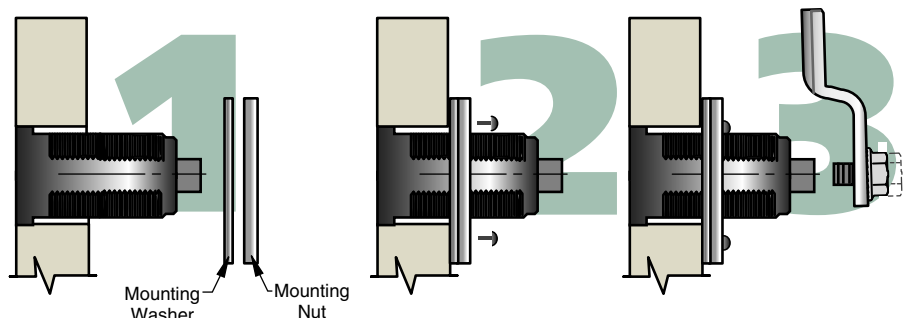

# Southco® Compression Latches

## Vise Action Series Knob Style

- Single-hole mount, large size
- Wider flange for mounting in non-metallic materials
- Knob provides quick, unrestricted access



Accessory for this latch. See page 36.

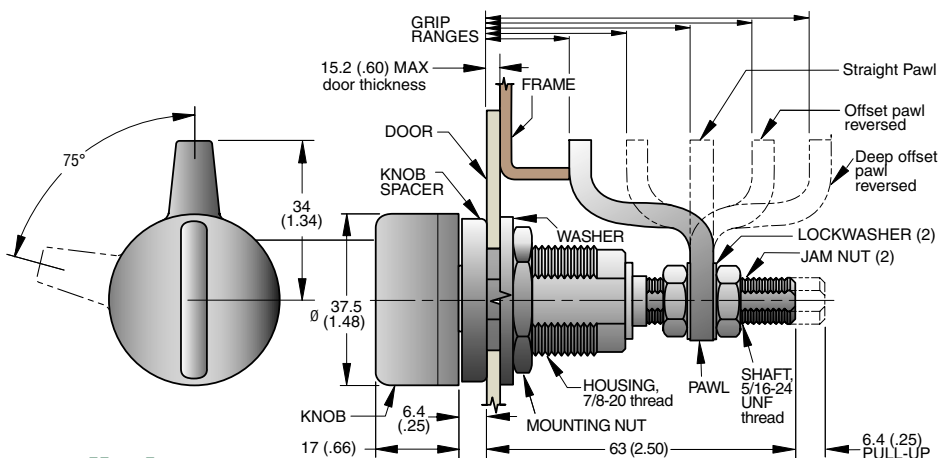

### Installation

1.

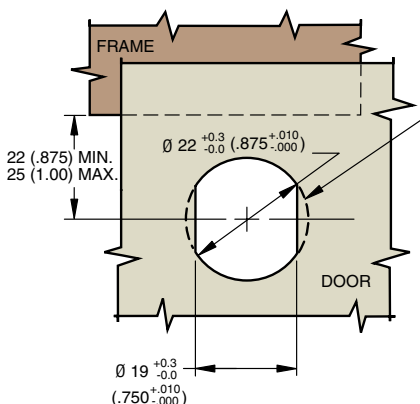

2.

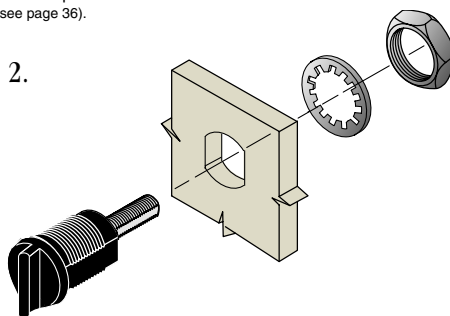

3.

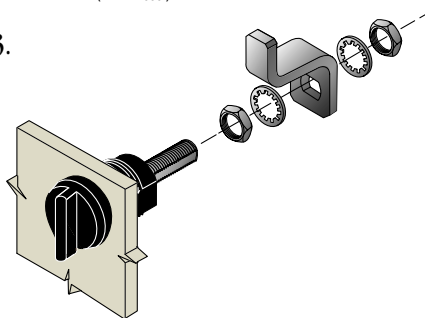

4. **To adjust grip:** Measure your grip. Open door. Position pawl on shaft to your grip measurement (with pawl in latched position). Tighten jam nuts hard against lock-washers and pawl using two wrenches.

### For gasketed doors:

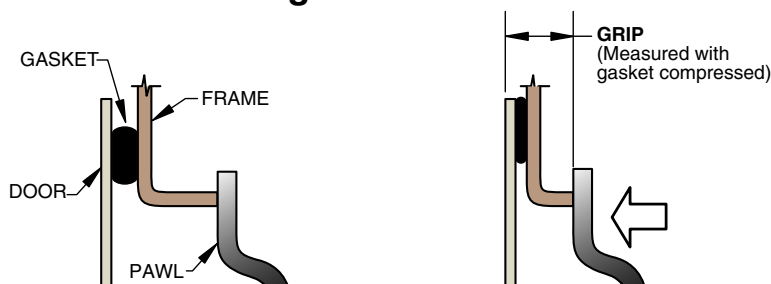

**CAUTION:** Set pawl position so that no more than 3.4 N•m (30 in.-lbs.) of torque is required to secure door.

### Material and Finish

**HOUSING:** Die cast zinc, black powder coated.

**SPRING:** 302 Stainless steel, natural.

**O-RING:** Buna-N rubber, black.

**PIN:** 1008 Steel, zinc plated plus chromate dip.

**WASHER and PAWL:** 1010 Steel, zinc plate, chromate plus sealer.

**CAM and SLEEVE:** 1075 Case hardened steel, zinc immersion coating.

**SHAFT:** Low carbon steel, zinc plate, chromate plus sealer.

**JAM NUTS:** Steel, zinc plate, chromate plus sealer.

**LOCKWASHERS:** Spring steel, zinc plate, chromate plus sealer.

**MOUNTING NUT:** Brass, zinc plate, chromate plus sealer.

**KNOB:** Glass filled nylon, black.

**KNOB SPACER:** Nylon, black.

**RETAINER:** Polycarbonate, black.

GRIP RANGE		PART NUMBERS
MIN.	MAX.	
10 (.39)	27 (1.06)	E3-10-504-50 * •
24 (.94)	40 (1.57)	E3-10-505-50 * •
36 (1.42)	52.5 (2.06)	E3-10-506-50 ‡ •
49 (1.94)	65.5 (2.57)	E3-10-505-50 * •
63.5 (2.50)	79 (3.11)	E3-10-504-50 * •

Spur Washer listed on page, 36.

\* The same pawl (curved forward or reversed) is supplied for both short and long grips.

‡ For intermediate grip, straight pawl is supplied.

### Product Strength Guidelines

(To assist in your product selection; samples are available for your evaluation.)

Maximum static load: 445 N (100 lbs.)

Average ultimate load: 890 N (200 lbs.)

millimeter (inch)  
millimeter  
(inch)

Dimensions without tolerances are for reference only.