

Screw Plug Immersion Heaters

Screw Plug Immersion Heaters consist of tubular elements welded or brazed into a threaded screw plug which can then be inserted into a threaded opening in a tank wall or through a mating full or half coupling.

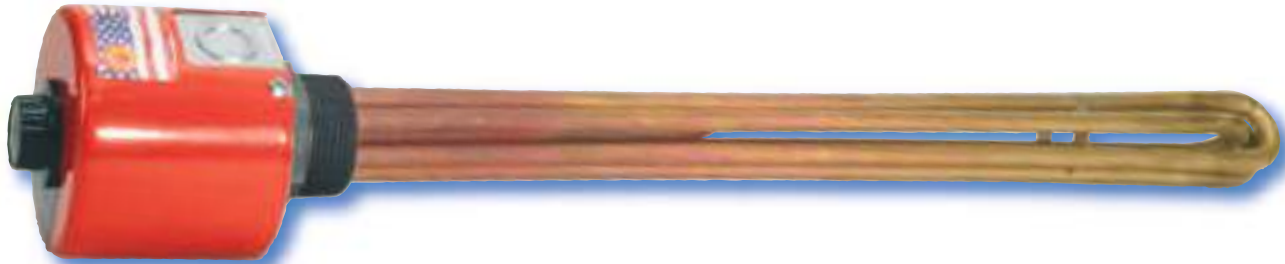

Design Features

- * *Stainless Steel, Brass or Steel Screw Plugs*
- * *Four Standard Screw Plug Sizes—1", 1-1/4", 2", 2-1/2"*
- * *Recompact element bends restore insulation resistance after forming*
- * *Thermowell for optional bulb & capillary thermostat, RTD or T/C probe*
- * *Corrosion-Resistant electrical wiring hardware*
- * *Four standard sheath materials — Copper, Steel, 316 Stainless Steel and Incoloy®800*
- * *NEMA 1 round terminal housing*
- * *Silicone resin element seal standard*

Optional Features

- * *NEMA 4 Moisture-Proof and/or NEMA 7 Explosion-Resistant terminal housings*
- * *Integral Single or Double Pole Thermostats in various temperature ranges to suit the application*
- * *Passivation, Electropolishing or Bright Annealing surface treatments available for Stainless Steel & Incoloy® elements*
- * *Type J & K Thermocouples or RTD probes for sensing process temperatures, or over-temperature protection when attached to the sheath*
- * *Special sheath materials*
- * *Special straight bulkhead or European thread fittings*

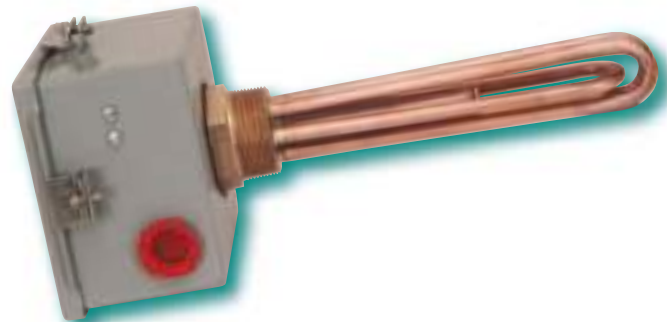

For Type TSP Screw Plug Heaters used in UL Recognized Oil Immersion Heating Applications

- The heated oil temperature cannot exceed 257°F (125°C)
- Steel sheath elements are limited to 60 watts/in²
- Steel or Stainless Steel mounting plugs (no Brass)
- Heaters with tapered threads (NPT, BSPT, or Metric) are UL rated for 60 psig maximum

Contact Tempco for other application specific UL file information.



Tempco Screw Plug Immersion Heaters are UL recognized and CSA certified in many design variations. The UL File Numbers are E90771 (CCN ÜBJY2/8) for heaters not containing a thermostat and E234452 (CCN KSXF2) for heaters used in water based solutions that include a thermostat. Tempco's equivalent CSA file number is 043099. Screw Plug heating elements and assemblies with thermostats have additionally been evaluated to UL574 (File Number MP4154) under CCN MDST2/8 for oil heating applications.

If you require UL, CSA, or other NRTL agency approvals, please specify when ordering.

View Product Inventory @ www.tempco.com

Checklist – Selecting the Proper Screw Plug Heater

Determine a Safe and Efficient Element Watt Density

Element Watt Density is the wattage dissipated per square inch of the element sheath surface and is calculated with the following formula.

$$\text{Watt Density} = \frac{\text{element wattage}}{\pi \times \text{element dia.} \times \text{element heated length}}$$

For a particular application, element watt density will govern element sheath temperature.

Factors to consider when choosing a suitable watt density are:

1. Many materials are heat sensitive and can decompose or be damaged if the element is running too hot.
2. Air and other gases that are poor conductors of heat require watt densities matched to the velocity of the gas flow to prevent element overheating.
3. When heating hard water and cleaning solutions mineral deposits can build up on the element sheath, acting as a heat insulator and raising the internal element temperature. If these deposits cannot be periodically removed, use a lower watt density element to increase heater life expectancy.

Select the Element Sheath Material

Sheath Material Selection

CORROSION. In addition to selecting a sheath material that is compatible with the heated medium, other factors that affect corrosion need to be considered.

1. The temperature of the corrodent. As temperature increases the degree of corrosion increases. Also remember that usually the element temperature is higher than the material it is heating.
2. The degree of aeration to which a corrodent is exposed. Stagnant conditions can deprive the stainless steels of oxygen, which is required to maintain their corrosion resistant surface.
3. Velocity of the corrodent. Increased velocity can increase the corrosion rate.



Note: See pages 16-12 through 16-20 for the recommended sheath materials for many immersion heating applications. If you are purchasing the material you are heating, check with the supplier for their recommendations.

Typical Applications

Copper Sheath—Process water, water with very weak chemical solutions, potable water, hot water storage for washrooms, showers, cleaning and rinsing parts, for freeze protection of cooling towers and sprinkler systems and other aqueous solutions not corrosive to copper sheath. Sheath temperatures to 350°F (177°C).

Incoloy® Sheath—Weak chemical solutions, oils, tar, caustic soda, detergent, alkaline solutions, molten salts, demineralized, deionized or pure water (sheath passivation is recommended), and other aqueous solutions not corrosive to Incoloy® sheath. Air, gas mixtures and superheated steam. Sheath temperatures to 1600°F (871°C).

Steel Sheath—Fluid heat transfer media, tar, high to low viscosity petroleum oils, asphalt, wax, paraffin, degreasing solvents, alcohol, molten salt, and other solutions not corrosive to steel sheath. Sheath temperatures to 750°F (399°C).

Surface Treatments for Stainless Steel and Incoloy® Elements and other Wetted Parts to Improve Corrosion Resistance

Screw Plug Immersion Heater surfaces in contact with the material being heated can be passivated or electro-polished to improve their resistance to corrosion.

Passivation removes surface contamination, usually iron, so that the optimum corrosion resistance of the stainless steel is maintained. Surface contamination would come from the small amount of steel that may be worn off a tool during the manufacturing process. Passivating is accomplished by dipping the heater in a warm solution of nitric acid.

Electro-Polishing is an electrochemical process that removes surface imperfections and contaminants, enhancing the corrosion resisting ability of the stainless steels. The resultant surface is clean, smooth and bright. Many medical and food applications require this finish.

CONTINUED

Checklist — Selecting the Proper Screw Plug Heater, *continued*

Select the Terminal Housing Type

Standard catalog screw plug immersion heaters are supplied with the **Type 1N** general purpose (NEMA 1) terminal housing with a single Dual 1/2-3/4 conduit knockout as shown on page 11-2. Additional housings with and without a thermostat include:

Moisture Resistant (NEMA 4)

Explosion Resistant (NEMA 7)

Moisture/Explosion Resistant (NEMA 4/7)

If the housings on this page do not meet the size, construction or other criteria of your application, consult Tempco with your requirements.



Explosion resistant terminal housings are intended to provide containment of an explosion in the enclosure only. No portion of the heater assembly outside the enclosure is covered under this NEMA rating. Abnormal use of a heater which results in excessive temperature can create hazardous conditions such as a fire. Never perform any type of service nor remove the housing cover prior to disconnecting all electrical power to the heater.

Standard NEMA 1 Housing Dimensions

TYPE 1N
(for no thermostat)
for 1", 1-1/4", 2" and 2-1/2"
Screw Plug Heaters

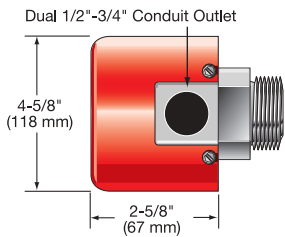

TYPE 1T
(for a single pole thermostat)
for 1", 1-1/4", 2" and 2-1/2"
Screw Plug Heaters

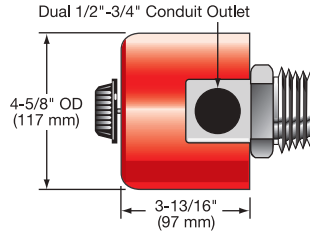

TYPE 6T
(for a double pole thermostat)
for 1", 1-1/4", 2" and 2-1/2"
Screw Plug Heaters

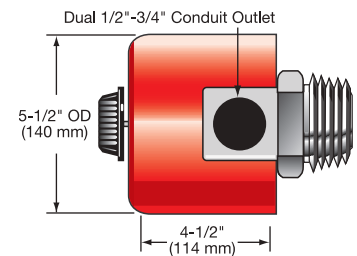

Standard NEMA 4 and/or 7 Housing Dimensions

NEMA 4 rating requires the use of the cover gasket.

TYPE 2N
(for no thermostat)
for 1", 1-1/4", 2" and 2-1/2"
Screw Plug Heaters

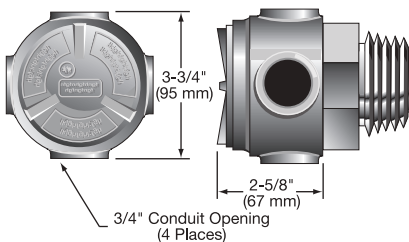

TYPE 2T
(for use with a single pole thermostat)
for 1" and 1-1/4" Screw Plug Heaters

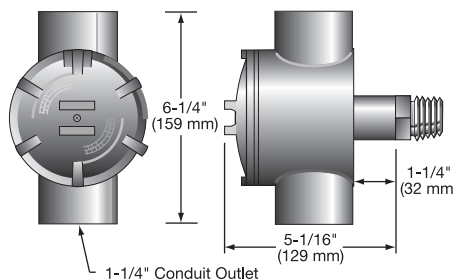

TYPE 3T
(for use with a double pole thermostat)
for 2" and 2-1/2" Screw Plug Heaters

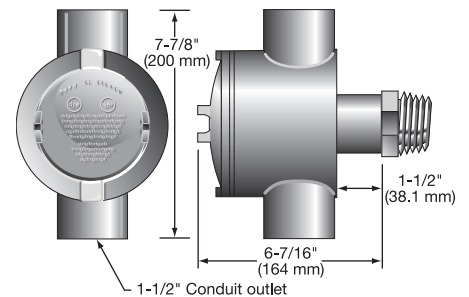

Screw Plug Immersion Heaters

Alternate NEMA 1 Housing

Type 3N

(for no thermostat)

for 1", 1-1/4", 2" and 2-1/2" Screw Plug Heaters

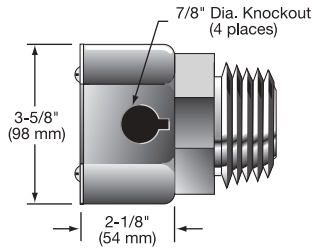

Alternate NEMA 4 Housing

TYPE 4N

(for no thermostat)

for 1", 1-1/4", 2" and 2-1/2" Screw Plug Heaters

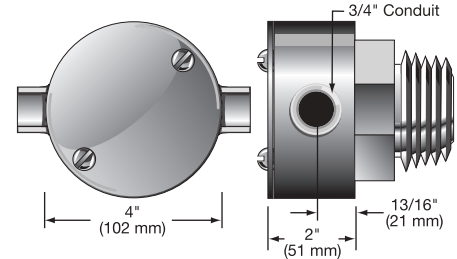

Alternate NEMA 4 Housing

TYPE 4T

(for a single pole thermostat)

for 1" and 1-1/4" Screw Plug Heaters

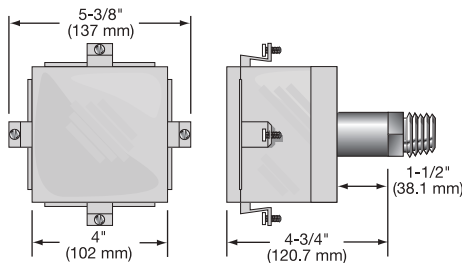

Alternate NEMA 4 Housing

TYPE 5T

(for a single or double pole thermostat)

for 2" and 2-1/2" Screw Plug Heaters

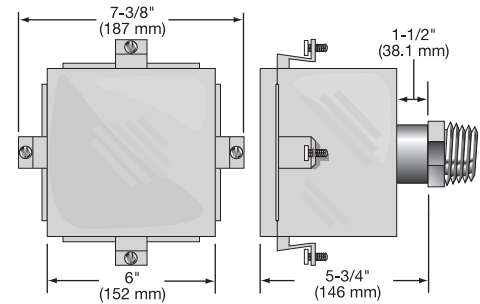

Wiring Diagrams — Screw Plug Heaters with Two Elements

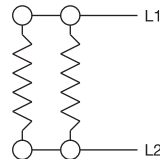
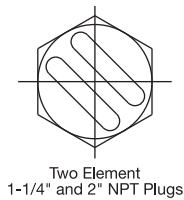

Note: Dual-Voltage heaters are factory wired for the higher voltage (series connection) unless otherwise specified. Easily rewired for lower voltage operation (parallel connection).

Wiring Diagrams — Screw Plug Heaters with Three Elements

Three Element
Crisscross Pattern
2" NPT Plugs
(Optional on 2-1/2" NPT Plugs)

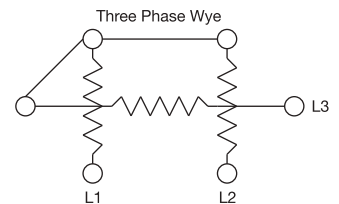
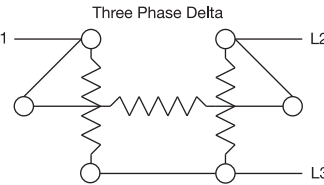
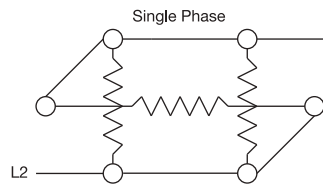
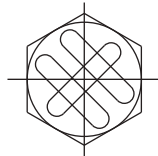

Three Element
Parallel Pattern
2-1/2" NPT Plugs

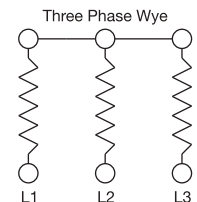
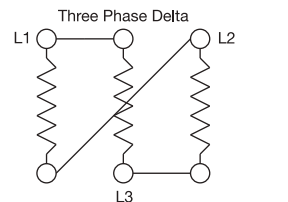
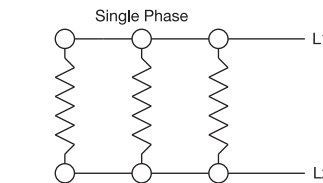
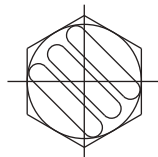

NOTE: Standard screw plug immersion heaters with three elements, factory wired for three-phase delta, can be rewired for single-phase operation with no wattage change. Wattage can be reduced to one-third of the designed wattage by switching from three-phase delta to wye connection.



Heaters wired for three-phase wye should not be changed to single-phase or three-phase delta connection, since this will increase wattage and watt density on the elements by three times the original designed wattage, causing premature heater failure.

Thermostat Styles and Selection

Construction Characteristics

This type of control operates by expansion and contraction of a liquid in response to temperature change. Liquid contained within the sensing bulb and capillary

flexes a diaphragm, causing the opening and closing of a snap-action switch. For heating applications the contacts are normally closed and open on temperature rise.

Style A Single-Pole Thermostat

Style B Double-Pole Thermostat



- * General purpose thermostat recommended for most applications.
- * Capable of controlling loads from 120V/30A up to 480V/20A

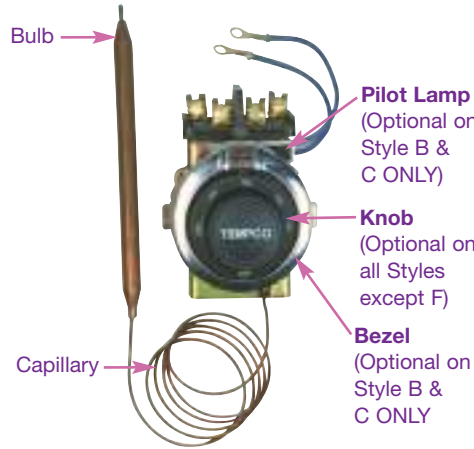

- * Recommended for directly controlling high wattage loads due to its heavy duty contacts.
- * Capable of controlling loads up to 30 Amps at 277 VAC and 10 Amps at 480 VAC

Thermostat Electrical Ratings: Normally Closed Contacts, Open on Temperature Rise – Adjustable

Stock Items Are Shown In RED

Control Type	Style	Temp Range °F	Ampacity at Line Voltage				Bulb Dia. in	Bulb Length in	Capillary Length in	Terminals	Thermostat Part Number	Optional Thermostat Parts			Instruction Sheet P/N
			120V	240V	277V	480V						Knob	Bezel	Pilot Lamp	
SPST	A	60–250	30	30	30	—	0.27	6.00	12	#10 screw	TST-101-137	TST-104-103	n/a	n/a	IDP-119-102
		60–250	30	30	30	—	0.38	4.63	48	#10 screw	TST-101-131	TST-104-103	n/a	n/a	IDP-119-102
		70–245	30	30	15	15	0.25	5.50	12	#10 screw	TST-101-130	Included	n/a	n/a	IDP-119-102
		150–550	30	30	30	—	0.31	5.00	48	#10 screw	TST-101-132	TST-104-109	n/a	n/a	IDP-119-102
		150–560	30	30	30	20	0.33	3.70	12	#10 screw	TST-101-113	TST-104-109	n/a	n/a	IDP-119-102
		200–400	30	30	30	20	0.31	5.00	36	#10 screw	TST-101-121	TST-104-112	n/a	n/a	IDP-119-102
DPST	B	30–110	30	30	30	10	0.38	6.31	36	#10 screw	TST-110-101	TST-104-110	TST-111-101	EHD-109-103	IDP-119-105
		60–250	30	30	30	10	0.38	3.88	18	#10 screw	TST-110-124	TST-104-103	TST-111-101	EHD-109-103	IDP-119-105
		60–250	30	30	30	10	0.38	3.88	24	#10 screw	TST-110-125	TST-104-103	TST-111-101	EHD-109-103	IDP-119-105
		60–250	30	30	30	10	0.38	3.88	36	#10 screw	TST-110-126	TST-104-103	TST-111-101	EHD-109-103	IDP-119-105
		60–250	30	30	30	10	0.38	3.88	60	#10 screw	TST-110-102	TST-104-103	TST-111-101	EHD-109-103	IDP-119-105
		60–250	30	30	30	10	0.38	4.5	156	#10 screw	TST-110-118	TST-104-103	TST-111-101	EHD-109-103	IDP-119-105
		100–550	30	30	30	10	0.38	3.13	24	#10 screw	TST-110-117	TST-104-104	TST-111-101	EHD-109-103	IDP-119-105
		100–550	30	30	30	10	0.38	3.88	48	#10 screw	TST-110-103	TST-104-104	TST-111-101	EHD-109-103	IDP-119-105



- Notes:**
- Knobs, Bezels and Pilot Lamps are optional and must be ordered separately from the thermostat.
 - Knob TST-104-119 graduated in °C (15-120) is available as an alternate for the standard TST-104-103 knob graduated in °F (60-250).
 - For Thermostat Enclosures refer to page 11-9.

Thermostat Wiring Diagrams

Thermostat Style A (Single Pole—Single Throw)

Typical circuit when voltage and/or line current does not exceed thermostat ratings

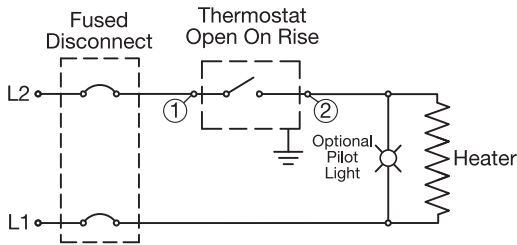

1Ø or 3Ø circuit if line voltage and/or current exceeds thermostat rating

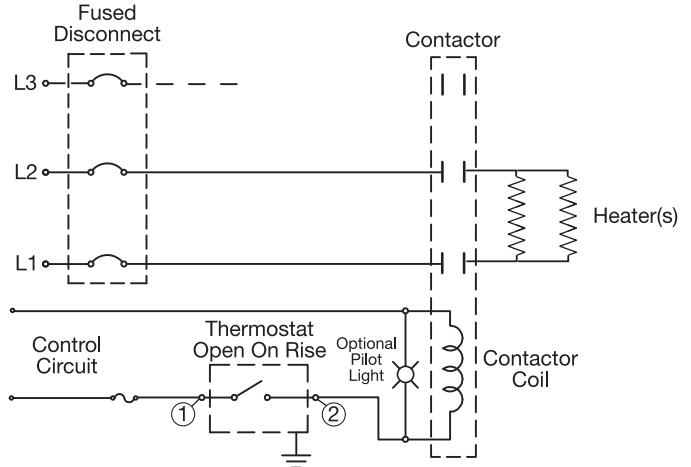

Thermostat Style B (Double Pole—Single Throw)

Typical circuit when voltage and/or line current does not exceed thermostat ratings

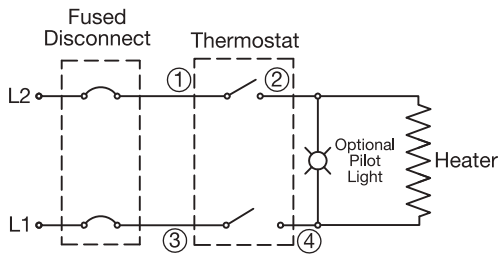

1Ø or 3Ø circuit if line voltage and/or current exceeds thermostat rating

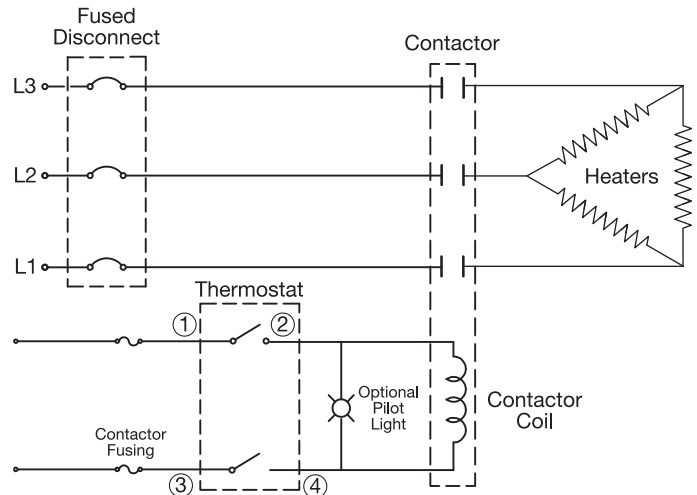

Stock Thermostat Kits

Double-Pole Thermostat Kits include the following components:

Kit Number TSTR-1008 with Style B Thermostat	
TST-110-103	Thermostat with 100 to 550°F Range
TST-104-104	Knob
EHD-109-103	Pilot lamp
TST-111-101	Bezel

Kit Number TSTR-1009 with Style B Thermostat	
TST-110-102	Thermostat with 60 to 250°F Range
TST-104-103	Knob
EHD-109-103	Pilot lamp
TST-111-101	Bezel



Note: Double-Pole Thermostat Kits can also be installed separately from the heater in housing HSGR-1004 shown on page 11-9.

Bulb & Capillary Thermostats

Thermostat Styles and Selection



Style C Double-Pole Thermostat

- * Secondary high limit circuit with manual reset
- * High limit tracks 25°F above setpoint temperature
- * High limit latches open until manual reset is pushed in the event that temperature goes up to 25°F above setpoint
- * Capable of controlling loads up to 30 Amps at 277 VAC



Style D Single-Pole Thermostat

- * General purpose thermostat recommended for most applications
- * Capable of controlling loads up to 25 Amps at 240 VAC

Thermostat Electrical Ratings: Normally Closed Contacts, Open on Temperature Rise – Adjustable

Stock Items Are Shown In RED

Control Type	Style	Temp Range °F	Ampacity at Line Voltage				Bulb Dia. in	Bulb Length in	Capillary Length in	Terminals	Thermostat Part Number	Optional Thermostat Parts			Instruction Sheet P/N
			120V	240V	277V	480V						Knob	Bezel	Pilot Lamp	
DPST	C	60-250	30	30	30	—	0.38	4.50	18	#10 screw	TST-110-127	TST-104-103	TST-111-102	EHD-109-103	IDP-119-106
		60-250	30	30	30	—	0.38	4.50	24	#10 screw	TST-110-128	TST-104-103	TST-111-102	EHD-109-103	IDP-119-106
		60-250	30	30	30	—	0.38	4.50	36	#10 screw	TST-110-129	TST-104-103	TST-111-102	EHD-109-103	IDP-119-106
		60-250	30	30	30	—	0.38	4.50	72	#10 screw	TST-110-113	TST-104-103	TST-111-102	EHD-109-103	IDP-119-106
SPST	D	20-120	25	25	—	—	0.26	4.15	24	6" leads	TST-101-109	TST-104-105	n/a	n/a	IDP-119-101
		40-107	25	25	—	—	0.27	5.88	6	6" leads	TST-101-119	TST-104-102	n/a	n/a	IDP-119-101
		47-107	25	25	—	—	0.32	2.85	8	6" leads	TST-101-106	TST-104-102	n/a	n/a	IDP-119-101
		55-115	25	25	—	—	0.26	3.70	42	6" leads	TST-101-118	TST-104-102	n/a	n/a	IDP-119-101
		60-180	22	22	18	—	0.28	4.20	6	6" leads	TST-101-105	screw adj.	n/a	n/a	IDP-119-101
		60-250	25	25	—	—	0.28	3.00	12	6" leads	TST-101-101	TST-104-101	n/a	n/a	IDP-119-101
SPDT	D	60-250	25	25	—	—	0.26	3.35	70	¼" quick conn.	TST-101-111	TST-104-101	n/a	n/a	IDP-119-101
SPDT	D	60-250	25	25	22	—	0.27	4.10	12	#10 screw	TST-101-116	TST-104-114	n/a	n/a	IDP-119-103

NOTES:

- Knobs, Bezels and Pilot Lamps are optional and must be ordered separately from the thermostat.
- Knob **TST-104-119** graduated in °C (15-120) is available as an alternate for the standard TST-104-103 knob graduated in °F (60-250).
- Knob **TST-104-105** is a plain pointer knob, not calibrated for the range.
- Knob **TST-104-102** is printed with 4 through 10, not calibrated for the range.
- For Thermostat Enclosures refer to page 11-9.

Thermostat Style C (Double Pole—Single Throw) with Reset

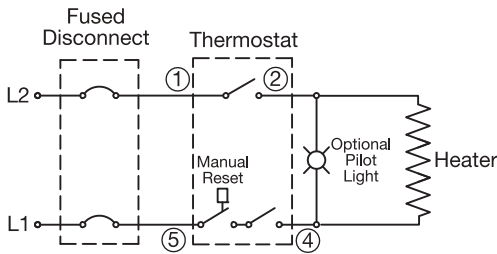

Typical circuit when voltage and/or line current does not exceed thermostat ratings

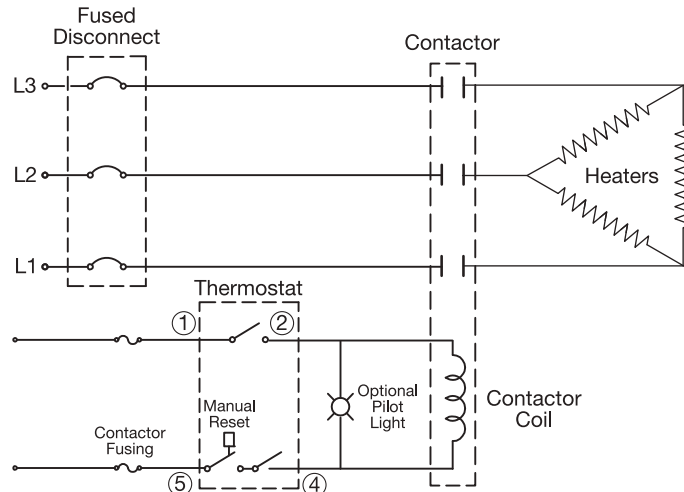

1Ø or 3Ø circuit if line voltage and/or current exceeds thermostat rating

Thermostat Wiring Diagrams

Thermostat Style D (Single Pole—Single Throw)

Typical circuit when voltage and/or line current does not exceed thermostat ratings

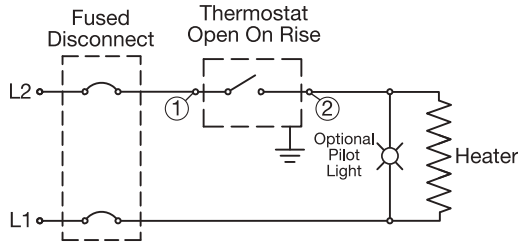

1Ø or 3Ø circuit if line voltage and/or current exceeds thermostat rating

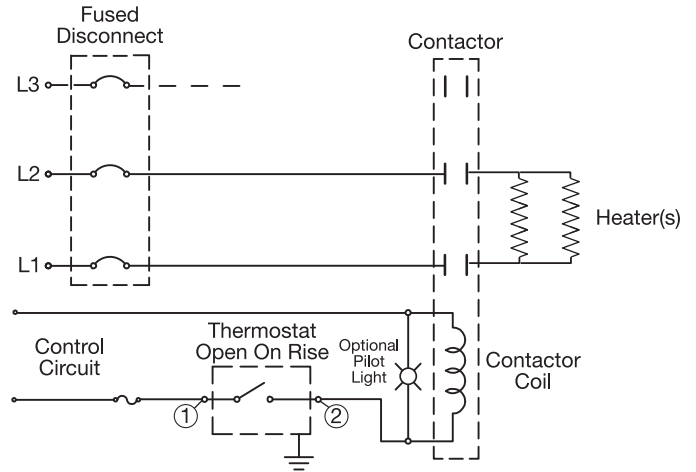

Thermostat Style D (Single Pole—Double Throw)

Typical circuit when voltage and/or line current does not exceed thermostat ratings

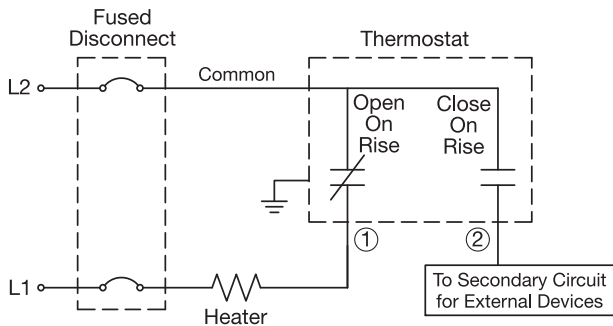

1Ø or 3Ø circuit if line voltage and/or current exceeds thermostat rating

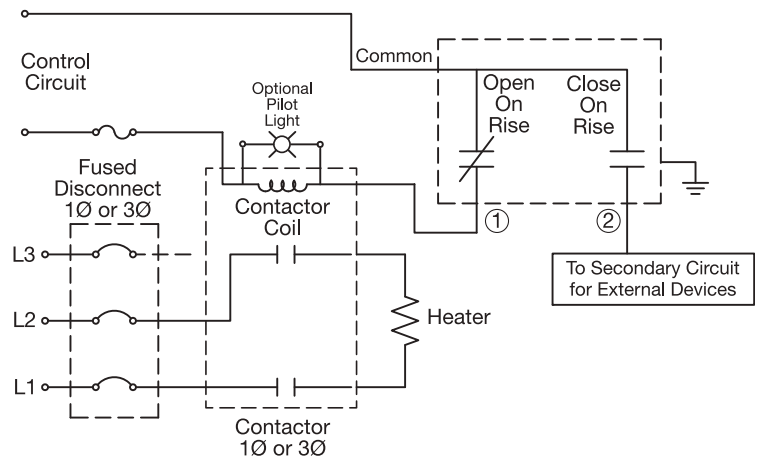

Stock Thermostat Enclosures

Thermostat Installation Warnings & Recommendations

1. Do not use the thermostat as a power switch. Use some other means of disconnecting power to the heater for servicing.
2. A thermostat is not a fail-safe device. Use an approved high temperature limit control and/or pressure limit control for safe operation.
3. Avoid kinking or bending the capillary tube too sharply as this will alter the calibration and/or render the thermostat inoperable.
4. Excess capillary tube should be coiled neatly in junction box.
5. The capillary tube must never touch the thermostat contacts as this will create an electrical short capable of harming personnel and/or equipment.



NEMA 1 Enclosure

For Single-Pole Thermostats
Size: 4-1/4"H × 3"W × 2"D
with 3/4" trade size knockout
Part Number: HSGR-1003



NEMA 1 Enclosure

For Double-Pole Thermostats
Size: 5-3/4"H × 3"W × 2"D with 1/2"
trade size knockout
Used with Thermostat kits TSTR-1008
and TSTR-1009 shown on page 11-7.
Part Number: HSGR-1004

Style F Temperature High Limit Switch with Manual Reset

Thermostat Electrical Ratings: High Limit – Manual Reset, Normally Closed Contacts, Open on Temperature Rise at Fixed Temperature

Stock Items Are Shown In **RED**



Control Type	Style	Temp Range °F	Ampacity at Line Voltage				Bulb Dia. in	Bulb Length in	Capillary Length in	Terminal	Thermostat Part Number	Instruction Sheet P/N
			120V	240V	277V	480V						
SPST	F1	118 ±3	30	30	20	20	0.32	3.00	12	#10 screw	TST-103-102	IDP-119-104
	F1	118 ±4	30	30	20	20	0.27	3.35	6	#10 screw	TST-103-109	IDP-119-104
	F1	125 ±2	30	30	20	20	0.25	3.35	36	#10 screw	TST-103-108	IDP-119-104
	F1	165 ±15	30	30	20	20	0.21	2.63	30	#10 screw	TST-103-107	IDP-119-104
	F1	200 ±5	30	30	20	20	0.31	4.00	12	#10 screw	TST-103-104	IDP-119-104
	F1	350 ±8	30	30	20	20	0.25	3.50	36	#10 screw	TST-103-103	IDP-119-104
	F2	420 ±15	30	30	30	30	0.25	4.85	30	#10 screw	TST-103-110	IDP-119-104
	F1	572 ±15	30	30	30	20	0.21	2.63	30	#10 screw	TST-103-106	IDP-119-104

NOTES: F2 style has a side vertical mounting bracket instead of #8 tapped holes for mounting. Refer to IDP-119-104 for mounting details.

Hi-Limit Thermostat Style F (Single Pole—Single Throw)

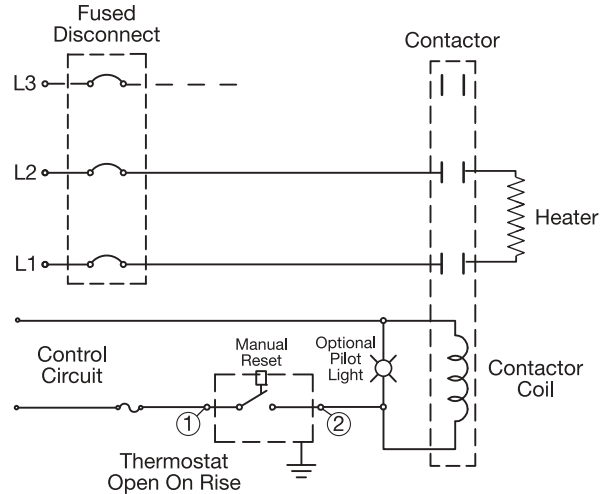
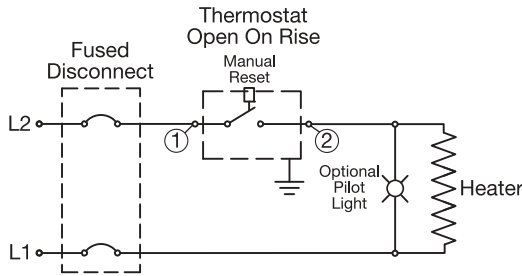

- * General purpose high limit switch with manual reset
- * Once fixed trip point is reached, the high limit switch will remain open until the manual reset button is pushed



Thermowells (Stainless Steel or Plain Steel)

Thermowells provide protection for bulb and capillary sensors. They are supplied with a 1/2" NPT male thread for mounting and a 3/8" NPT internal thread that can be used with the stuffing box assembly to secure the capillary to the well. ID: 0.50", OD: 0.56" See pages 14-76 through 14-83 for other thermowell styles.

Stock Items Are Shown In **RED**

Immersed Length		Part Number	
in	mm	Steel	Stainless Steel
12	305	MPT-120-101	MPT-121-101
18	457	MPT-120-102	MPT-121-102
24	610	MPT-120-103	MPT-121-103
36	914	MPT-120-104	MPT-121-104

Stuffing Box Assembly

The Stuffing Box Assembly is used to seal the thermostat capillary when the sensing bulb (3/8" max. OD) is immersed directly in a liquid rather than in a thermowell. The Stuffing Box consists of six slotted washers used to compress a graphite packing into a 3/8" NPT male pipe thread fitting.

Assembly Instructions

Feed sensing bulb through hole in upper and lower fitting. Insert washers and packing into top cavity of lower fitting. Upper fitting then screws into lower fitting, creating the seal.

Part Number: TST-109-101

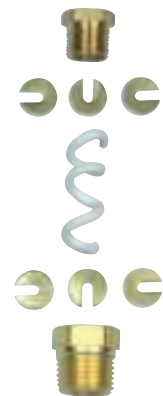

Standard (Non-Stock) and Stock Screw Plug Immersion Heaters

Stock Items Are Shown In **RED**

8 watts/in² (1.3 watts/cm²) — Typical Applications: Fuel Oils (Bunker C and Number 6)

* Steel Screw Plug * Steel Sheath Heating Elements * NEMA 1 Terminal Housing

NOTE: 3-Phase only. Cannot be rewired for single phase.

Nominal Pipe Size	Immersed Length		KW	Part Number		Approximate Net Weight	
	in	mm		240V-3Ph	480V-3Ph	lbs	kgs
2-1/2" NPT 3 elements	17 1/4	438	1	TSP01600	TSP01601	8	4
	24 3/4	629	1.5	TSP01602	TSP01603	9	4
	32 1/4	819	2	TSP01604	TSP01605	11	5
	39 3/4	1010	2.5	TSP01606	TSP01607	12	5
	47 1/4	1200	3	TSP01608	TSP01609	13	6
	63 3/4	1619	4	TSP01610	TSP01611	16	7
	76 1/4	1937	5	TSP01612	TSP01613	18	8

15 watts/in² (2.3 watts/cm²) — Typical Applications: Medium Weight Oils • Heat Transfer Oils

* Steel Screw Plug * Steel Sheath Heating Elements * NEMA 1 Terminal Housing

NOTE: Part Numbers followed by a ① are 3-Phase only. Other 3-Phase heaters are convertible to 1-Phase.

Nominal Pipe Size	Immersed Length		KW	Part Number		Approximate Net Weight	
	in	mm		240V-3Ph	480V-3Ph	lbs	kgs
2" NPT 3 elements	13 1/4	337	1.5	TSP01614	TSP01615①	6	3
	17 1/2	445	2	TSP01616	TSP01617①	7	3
	20 1/2	521	2.5	TSP01618	TSP01619①	7	3
	25	635	3	TSP01620	TSP01621	8	4
	32 1/2	826	4	TSP01622	TSP01623	9	4
	40	1016	5	TSP01624	TSP01625	10	5
	47 1/2	1207	6	TSP01626	TSP01627	11	5
	58 1/2	1486	7.5	TSP01628	TSP01629	12	5
	69 3/4	1772	9	TSP01630	TSP01631	14	6

Screw Plug Heater Dimensions

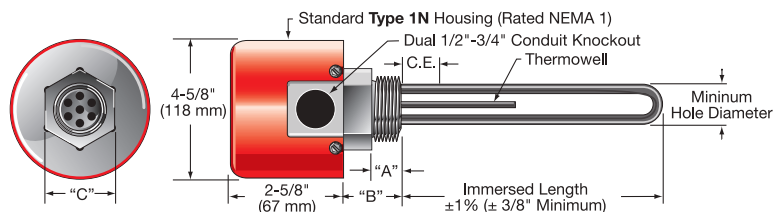

Screw Plug NPT	Minimum Hole Diameter		"A"		"B"		"C"		Thermowell Bulb Size		Standard Cold Ends (CE)		Element Diameter	
	in	mm	in	mm	in	mm	in	mm	in	mm	in	mm	in	mm
1"	1-1/8	29	7/8	22	1-1/4	32	1-3/8	35	1/4	6.4	1	25	.315	8
1-1/4"	1-3/8	35	15/16	24	1-5/16	33	1-3/4	44	1/4	6.4	1	25	.315	9
2"	2-1/4	57	1-1/16	27	1-9/16	40	2-1/2	64	3/8	9.5	2	50	.430	11
2-1/2"	2-1/2	64	1-5/16	33	2-1/16	52	3	76	3/8	9.5	2	50	.475	12

Ordering Information

See Page 11-16 for complete Ordering Information.

Standard (Non-Stock) and Stock Screw Plug Immersion Heaters

Stock Items Are Shown In RED

23 watts/in² (3.6 watts/cm²) — Typical Applications: Lightweight Oils • Degreasing Solutions • Heat Transfer Oils

* Steel Screw Plug

* Steel Sheath Heating Elements

* NEMA 1 Terminal Housing

NOTE: Dual-Voltage heaters are 1-Phase and are wired for the higher voltage unless otherwise specified.
Part Numbers followed by a ① are 3-Phase only. Other 3-Phase heaters are convertible to 1-Phase.

Nominal Pipe Size	Immersed Length		KW	Part Number						Approximate Net Weight	
	in	mm		120V-1Ph	120/240V	240V-1Ph	240V-3Ph	240/480V	480V-3Ph	lbs	kgs
1" NPT 1 element	6½	165	0.25	TSP01632	—	TSP01633	—	—	—	2	1
	7¼	200	0.3	TSP01634	—	TSP01635	—	—	—	2	1
	9¼	235	0.35	TSP01636	—	TSP01637	—	—	—	2	1
	9¾	238	0.5	TSP01638	—	TSP01639	—	—	—	2	1
	13½	343	0.75	TSP01640	—	TSP01641	—	—	—	3	1
	16¾	425	1	TSP01642	—	TSP01643	—	—	—	3	1
	23¾	603	1.5	TSP01644	—	TSP01645	—	—	—	3	1
1¼" NPT 2 elements	6¾	162	0.5	—	TSP01646	—	—	—	—	3	1
	8¾	225	0.7	—	TSP01647	—	—	—	—	3	1
	10½	256	0.75	—	TSP01648	—	—	—	—	4	2
	12¾	324	1	—	TSP01649	—	—	—	—	4	2
	19¾	492	1.5	—	TSP01650	—	—	—	—	4	2
	25¾	645	2	—	TSP01651	—	—	—	—	5	2
2" NPT 2 elements	36¾	937	3	—	TSP01652	—	—	—	—	5	2
	9½	241	1	—	TSP01653	—	—	TSP01654	—	5	2
	13½	343	1.5	—	TSP01655	—	—	TSP01656	—	5	2
	17½	445	2	—	TSP01657	—	—	TSP01658	—	6	3
	20½	521	2.5	—	TSP01659	—	—	TSP01660	—	6	3
	25	635	3	—	TSP01661	—	—	TSP01662	—	6	3
	32½	826	4	—	TSP01663	—	—	TSP01664	—	7	3
	40	1016	5	—	TSP01665	—	—	TSP01666	—	8	4
2" NPT 3 elements	47½	1207	6	—	—	—	—	TSP01667	—	8	4
	9½	241	1.5	TSP01668	—	—	TSP01669	—	TSP01670①	5	2
	17½	445	3	TSP01671	—	—	TSP01672	—	TSP01673①	6	3
	22	559	3.75	TSP01674	—	—	TSP01675	—	TSP01676	7	3
	25	635	4.5	TSP01677	—	—	TSP01678	—	TSP01679	7	3
	32½	826	6	—	—	—	TSP01680	—	TSP01681	8	4
	40	1016	7.5	—	—	—	TSP01682	—	TSP01683	9	4
	47½	1207	9	—	—	—	TSP01684	—	TSP01685	10	5
2½" NPT 3 elements	64	1626	12.5	—	—	—	TSP01686	—	TSP01687	12	5
	17¼	438	3	TSP01688	—	—	TSP01689	—	TSP01690①	8	4
	19½	484	3.75	TSP01691	—	—	TSP01692	—	TSP01693	8	4
	24¾	629	4.5	TSP01694	—	—	TSP01695	—	TSP01696	9	4
	32¼	819	6	—	—	—	TSP01697	—	TSP01698	11	5
	39¾	1010	7.5	—	—	—	TSP01699	—	TSP01700	12	5
	47¼	1200	9	—	—	—	TSP01701	—	TSP01702	13	6
	63¾	1619	12.5	—	—	—	TSP01703	—	TSP01704	16	7
76¼	1937	15	—	—	—	TSP01705	—	TSP01706	18	8	

Screw Plug Heater Dimensions

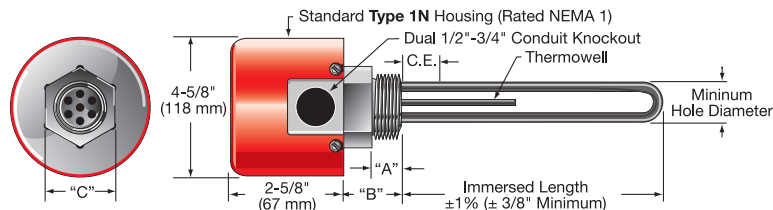

Screw Plug NPT	Minimum Hole Diameter		"A"		"B"		"C"		Thermowell Bulb Size		Standard Cold Ends (CE)		Element Diameter	
	in	mm	in	mm	in	mm	in	mm	in	mm	in	mm	in	mm
1"	1-1/8	29	7/8	22	1-1/4	32	1-3/8	35	1/4	6.4	1	25	.315	8
1-1/4"	1-3/8	35	15/16	24	1-5/16	33	1-3/4	44	1/4	6.4	1	25	.315	9
2"	2-1/4	57	1-1/16	27	1-9/16	40	2-1/2	64	3/8	9.5	2	50	.430	11
2-1/2"	2-1/2	64	1-5/16	33	2-1/16	52	3	76	3/8	9.5	2	50	.475	12



Standard (Non-Stock) and Stock Screw Plug Immersion Heaters

Stock Items Are Shown In **RED**

16 watts/in² (2.5 watts/cm²) — Typical Applications: Medium Weight Oils • Heat Transfer Oils • Liquid Paraffin

- * 304 Stainless Steel Screw Plug * Incoloy®800 Sheath Heating Elements * NEMA 1 Terminal Housing

NOTE: 3-Phase only. Cannot be rewired for single phase.

Nominal Pipe Size	Immersed Length		KW	Part Number		Approximate Net Weight	
	in	mm		240V-3Ph	480V-3Ph	lbs	kgs
2" NPT 3 elements	9¾	248	1	TSP01707	TSP01708	4	2
	13¾	337	1.5	TSP01709	TSP01710	5	2
	17¾	451	2	TSP01711	TSP01712	6	3
	20¾	514	2.5	TSP01713	TSP01714	6	3
	25¾	641	3	TSP01715	TSP01716	7	3
	32¾	832	4	TSP01717	TSP01718	8	4
	40¾	1022	5	TSP01719	TSP01720	9	4
	47¾	1213	6	TSP01721	TSP01722	10	5
2-1/2" NPT 3 elements	9¾	238	1	TSP01723	TSP01724	7	3
	12¾	327	1.5	TSP01725	TSP01726	8	4
	17¾	441	2	TSP01727	TSP01728	8	4
	19¾	505	2.5	TSP01729	TSP01730	9	4
	24¾	632	3	TSP01731	TSP01732	10	5
	32¾	822	4	TSP01733	TSP01734	11	5
	39¾	1013	5	TSP01735	TSP01736	12	5
	47¾	1203	6	TSP01737	TSP01738	13	6

23 watts/in² (3.6 watts/cm²) — Typical Applications: Forced Air & Gases • Caustic Solutions • Degreasing Solutions

- * 304 Stainless Steel Screw Plug * Incoloy®800 Sheath Heating Elements * NEMA 1 Terminal Housing

NOTE: Dual-Voltage heaters are 1-Phase and are wired for the higher voltage unless otherwise specified.

Part Numbers followed by a ① are 3-Phase only. Other 3-Phase heaters are convertible to 1-Phase.

Nominal Pipe Size	Immersed Length		KW	Part Number				Approximate Net Weight	
	in	mm		120V-1Ph	120/240V	240V-3Ph	480V-3Ph	lbs	kgs
1-1/4" NPT 2 elements	13¾	340	1	—	TSP01739	—	—	3	1
	19	483	1.5	—	TSP01740	—	—	3	1
	24¾	619	2	—	TSP01741	—	—	4	2
2" NPT 3 elements	17¾	451	3	TSP01742	—	TSP01743	TSP01744①	5	2
	25¾	641	4.5	TSP01745	—	TSP01746	TSP01747	6	3
	32¾	832	6	—	—	TSP01748	TSP01749	7	3
	40¾	1022	7.5	—	—	TSP01750	TSP01751	9	4
	47¾	1213	9	—	—	TSP01752	TSP01753	10	5
	64¾	1632	12.5	—	—	TSP01754	TSP01755	12	5
2-1/2" NPT 3 elements	76¾	1950	15	—	—	TSP01756	TSP01757	13	6
	17¾	441	3	TSP01758	—	TSP01759	TSP01760 ①	8	4
	24¾	632	4.5	TSP01761	—	TSP01762	TSP01763	9	4
	32¾	822	6	—	—	TSP01764	TSP01765	11	5
	39¾	1013	7.5	—	—	TSP01766	TSP01767	12	5
	47¾	1203	9	—	—	TSP01768	TSP01769	13	6
	63¾	1622	12.5	—	—	TSP01770	TSP01771	16	7
76¾	1940	15	—	—	TSP01772	TSP01773	18	8	

Ordering Information

See Page 11-16 for complete Ordering Information.

Screw Plug Immersion Heaters

Standard (Non-Stock) and Stock Screw Plug Immersion Heaters

Stock Items Are Shown In RED

48 watts/in² (7.5 watts/cm²) — Typical Applications: Process Water

* 304 Stainless Steel Screw Plug * Incoloy®800 Sheath Heating Elements * NEMA 1 Terminal Housing

NOTE: Dual-Voltage heaters are 1-Phase and are wired for the higher voltage unless otherwise specified. Part Numbers followed by a ① are 3-Phase only. Other 3-Phase heaters are convertible to 1-Phase.

Nominal Pipe Size	Immersed Length		KW	Part Number				Approximate Net Weight		
	in	mm		120V-1Ph	120/240V	240V-3Ph	240/480V	480V-3Ph	lbs	kgs
2" NPT 2 elements	9¾	248	2	—	TSP01774	—	TSP01775	—	4	2
	13¾	337	3	—	TSP01776	—	TSP01777	—	4	2
	17¾	451	4	—	TSP01778	—	TSP01779	—	5	2
	20¾	514	5	—	TSP01780	—	TSP01781	—	5	2
	25¾	641	6	—	—	—	TSP01783	—	6	3
	32¾	832	8	—	—	—	TSP01784	—	6	3
	40¾	1022	10	—	—	—	TSP01785	—	7	3
2" NPT 3 elements	9¾	248	3	TSP01786	—	TSP01787	—	TSP01788①	5	2
	13¾	337	4.5	TSP01789	—	TSP01790	—	TSP01791①	5	2
	17¾	451	6	—	—	TSP01792	—	TSP01793	6	3
	20¾	514	7.5	—	—	TSP01794	—	TSP01795	6	3
	25¾	641	9	—	—	TSP01796	—	TSP01797	7	3
	32¾	832	12	—	—	TSP01798	—	TSP01799	8	4
	40¾	1022	15	—	—	TSP01800	—	TSP01801	9	4
2-1/2" NPT 3 elements	47¾	1213	18	—	—	TSP01802	—	TSP01803	10	5
	9¾	238	3	TSP01804	—	TSP01805	—	TSP01806①	7	3
	12¾	327	4.5	TSP01807	—	TSP01808	—	TSP01809①	8	4
	17¾	441	6	—	—	TSP01810	—	TSP01811	8	4
	19¾	505	7.5	—	—	TSP01812	—	TSP01813	9	4
	24¾	632	9	—	—	TSP01814	—	TSP01815	10	5
	32¾	822	12	—	—	TSP01816	—	TSP01817	11	5
39¾	1013	15	—	—	TSP01818	—	TSP01819	12	5	
47¾	1203	18	—	—	TSP01820	—	TSP01821	13	6	

Screw Plug Heater Dimensions

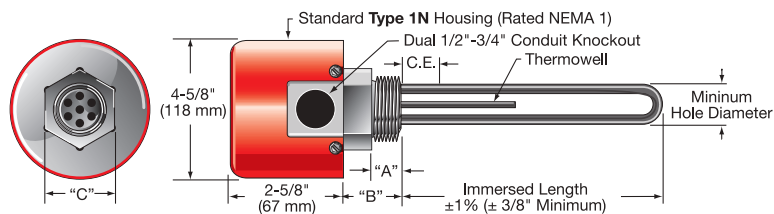

Screw Plug NPT	Minimum Hole Diameter		"A"		"B"		"C"		Thermowell Bulb Size		Standard Cold Ends (CE)		Element Diameter	
	in	mm	in	mm	in	mm	in	mm	in	mm	in	mm	in	mm
1"	1-1/8	29	7/8	22	1-1/4	32	1-3/8	35	1/4	6.4	1	25	.315	8
1-1/4"	1-3/8	35	15/16	24	1-5/16	33	1-3/4	44	1/4	6.4	1	25	.315	9
2"	2-1/4	57	1-1/16	27	1-9/16	40	2-1/2	64	3/8	9.5	2	50	.430	11
2-1/2"	2-1/2	64	1-5/16	33	2-1/16	52	3	76	3/8	9.5	2	50	.475	12



Standard (Non-Stock) and Stock Screw Plug Immersion Heaters

Stock Items Are Shown In **RED**

60 watts/in² (9.3 watts/cm²) — Typical Applications: Clean Water

* Brass Screw Plug * Copper Sheath Heating Elements * NEMA 1 Terminal Housing

NOTE: Dual-Voltage heaters are 1-Phase and are wired for the higher voltage unless otherwise specified. Part Numbers followed by a ① are 3-Phase only. Other 3-Phase heaters are convertible to 1-Phase.

Nominal Pipe Size	Immersed Length		KW	Part Number			Approximate Net Weight	
	in	mm		120V-1Ph	120/240V	240V-1Ph	lbs	kgs
1" NPT 1 element	4½	114	.5	TSP01840	—	TSP01841	2	1
	6½	165	.75	TSP01842	—	TSP01843	2	1
	6¾	168	1	TSP01844	—	TSP01845	2	1
	8	203	1.25	TSP01846	—	TSP01847	2	1
	9¼	235	1.5	TSP01848	—	TSP01849	3	1
	12½	318	2	TSP01850	—	TSP01851	3	1
	14¾	375	2.5	TSP01852	—	TSP01853	3	1
	16¾	426	3	TSP01854	—	TSP01855	3	1
1-1/4" NPT 1 element	21	533	4	—	—	TSP01856	3	1
	4¾	111	.5	TSP01857	—	TSP01858	3	1
1-1/4" NPT 2 elements	6¾	162	.75	TSP01859	—	TSP01860	3	1
	4¾	111	1	—	TSP01861	—	3	1
	6¾	162	1.5	—	TSP01862	—	3	1
	8½	216	2	—	TSP01863	—	3	1
	10¾	273	2.5	—	TSP01864	—	4	2
	15	381	3	—	TSP01865	—	4	2
	19	483	4	—	—	TSP01866	4	2
	23½	597	5	—	—	TSP01867	4	2
27½	699	6	—	—	TSP01868	5	2	

Nominal Pipe Size	Immersed Length		KW	Part Number				Approximate Net Weight		
	in	mm		120V-1Ph	120/240V	240V-3Ph	240/480V	480V-3Ph	lbs	kgs
2" NPT 2 elements	8¾	206	2	—	TSP01869	—	TSP01870	—	4	2
	11¾	283	3	—	TSP01871	—	TSP01872	—	4	2
	15¾	384	4	—	TSP01873	—	TSP01874	—	5	2
	18¾	460	5	—	TSP01875	—	TSP01876	—	5	2
	21¾	537	6	—	—	—	TSP01877	—	6	3
	26¾	676	8	—	—	—	TSP01878	—	6	3
2" NPT 3 elements	32¾	816	10	—	—	—	TSP01879	—	6	3
	8¾	206	3	TSP01880	—	TSP01881	—	TSP01882①	4	2
	11¾	283	4.5	TSP01883	—	TSP01884	—	TSP01885①	5	2
	15¾	384	6	—	—	TSP01886	—	TSP01887	5	2
	18¾	460	7.5	—	—	TSP01888	—	TSP01889	6	3
	21¾	537	9	—	—	TSP01890	—	TSP01891	6	3
2-1/2" NPT 3 elements	26¾	676	12	—	—	TSP01892	—	TSP01893	7	3
	32¾	816	15	—	—	TSP01894	—	TSP01895	8	4
	7¾	194	3	TSP01896	—	TSP01897	—	TSP01898①	4	2
	8¾	225	3.75	—	—	TSP01899	—	TSP01900①	5	2
	10¾	270	4.5	TSP01901	—	TSP01902	—	TSP01903①	5	2
	14¾	371	6	—	—	TSP01904	—	TSP01905	6	3
	17¾	448	7.5	—	—	TSP01906	—	TSP01907	6	3
	20¾	524	9	—	—	TSP01908	—	TSP01909	7	3
26¾	664	12	—	—	TSP01910	—	TSP01911	8	4	
31¾	803	15	—	—	TSP01912	—	TSP01913	9	4	
37¾	943	18	—	—	TSP01914	—	TSP01915	10	5	

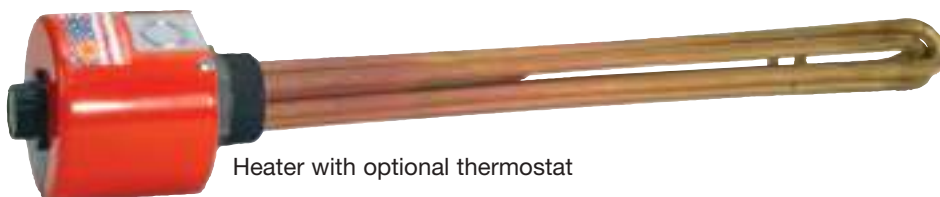

Ordering Information

See Page 11-16 for complete Ordering Information.

Standard (Non-Stock) and Stock Screw Plug Immersion Heaters

Stock Items Are Shown In **RED**

60 watts/in² (9.3 watts/cm²) — Typical Applications: **Deionized Water • Demineralized Water**

* 316 Stainless Steel Screw Plug * 316 SS Sheath Heating Elements * NEMA 1 Terminal Housing

NOTE: Part Numbers followed by a ① are 3-Phase only. Other 3-Phase heaters are convertible to 1-Phase.

Nominal Pipe Size	Immersed Length		KW	Part Number			Approximate Net Weight	
	in	mm		120V-1Ph	240V-3Ph	480V-3Ph	lbs	kgs
2-1/2" NPT 3 elements	7%	194	3	TSP01822	TSP01823	TSP01824①	7	3
	10%	270	4.5	TSP01825	TSP01826	TSP01827①	7	3
	14%	372	6	—	TSP01828	TSP01829	8	4
	17%	448	7.5	—	TSP01830	TSP01831	8	4
	20%	524	9	—	TSP01832	TSP01833	9	4
	26%	664	12	—	TSP01834	TSP01835	10	5
	31%	803	15	—	TSP01836	TSP01837	11	5
	37%	943	18	—	TSP01838	TSP01839	12	5

Screw Plug Heater Dimensions

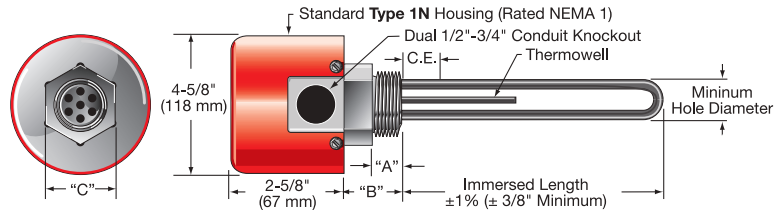

Screw Plug NPT	Minimum Hole Diameter		"A"		"B"		"C"		Thermowell Bulb Size		Standard Cold Ends (CE)		Element Diameter	
	in	mm	in	mm	in	mm	in	mm	in	mm	in	mm	in	mm
1"	1-1/8	29	7/8	22	1-1/4	32	1-3/8	35	1/4	6.4	1	25	.315	8
1-1/4"	1-3/8	35	15/16	24	1-5/16	33	1-3/4	44	1/4	6.4	1	25	.315	9
2"	2-1/4	57	1-1/16	27	1-9/16	40	2-1/2	64	3/8	9.5	2	50	.430	11
2-1/2"	2-1/2	64	1-5/16	33	2-1/16	52	3	76	3/8	9.5	2	50	.475	12

Ordering Information

Catalog Heaters

Screw Plug Immersion Heaters whose Part Numbers are in **RED** are in stock for immediate delivery.

Standard Non-Stock Part Numbers are stocked as sub-assemblies for 2-3 week delivery.

Custom Engineered/Manufactured Heaters

Understanding that an electric heater can be very application specific, for sizes and ratings not listed, **TEMPCO** will design and manufacture a Screw Plug Immersion Heater to meet your requirements.

Standard lead time is 4 weeks.

Please Specify the following:

- Wattage, Voltage and Phase
- Screw Plug Size and Material
- Element Sheath Material
- Element Watt Density
- Element Immersion Length
- Electrical Enclosure Type
- Thermostat— if required
- Optional Features

⚠ WARNING: Cancer and Reproductive Harm - www.P65Warnings.ca.gov.



Stock Screw Plug Immersion Heaters With and Without Thermostats

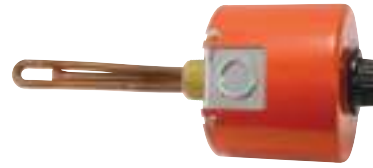
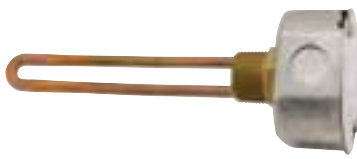

Design Features

* Brass Screw Plug

* Copper Elements

* NEMA 1 Terminal Housing

Nominal Pipe Size	Immersed Length in mm		KW	W/Sq.In.	Part Number				Approximate Net Weight lbs kgs	
					No Thermostat 120V-1Ph	With 60-250°F Thermostat 120V-1Ph	No Thermostat 240V-1Ph	With 60-250°F Thermostat 240V-1Ph		
1" NPT	6 ³ / ₈	162	0.5	46	TSP02007	TSP02078	—	—	3.1	1.4
	6 ³ / ₈	162	0.75	69	TSP02097	TSP02079	—	—	3.1	1.4
	6 ³ / ₈	162	1	92	TSP02096	TSP02080	—	—	3.1	1.4
	9 ¹ / ₄	235	1.5	90	TSP02099	TSP02081	—	—	3.5	1.6
1-1/4" NPT	6	152	1	90	TSP03340	TSP03260	TSP03341	TSP03261	3.2	1.5
	6 ¹ / ₂	165	2	94	TSP03342	TSP03262	TSP03343	TSP03263	3.4	1.5
	7 ¹ / ₄	184	1.5	60	TSP02100	TSP02082	—	—	3.6	1.6
	9	229	1.5	93	TSP03344	TSP03264	TSP03345	TSP03265	4.0	1.8
	9 ¹ / ₄	235	2	61	TSP02102	TSP02084	—	—	4.1	1.9

Nominal Pipe Size	Immersed Length in mm		KW	W/Sq.In.	Part Number				Approximate Net Weight lbs kgs	
					No Thermostat 240V-3Ph	With 60-250°F Thermostat 240V-3Ph	No Thermostat 480V-3Ph	With 60-250°F Thermostat 480V-3Ph		
2" NPT	8	203	2	40	TSP03214	TSP03213	—	—	6.5	3.0
	10	254	3	45	TSP02103	TSP02085	—	—	6.5	3.0
	11	279	4	54	TSP02104	TSP02086	—	—	6.6	3.0
	11	279	5	67	TSP02105	TSP02087	TSP02106	TSP02088	6.6	3.0
	16	406	7.5	65	TSP02107	TSP02089	TSP02008	TSP02090	7.4	3.4
2-1/2" NPT	22	559	10	61	TSP02009	TSP02091	TSP02022	TSP02092	9.5	4.3
	32 ¹ / ₄	819	12	61	—	—	TSP02108	TSP02093	12.0	5.5
	47 ³ / ₈	1203	18	44	—	—	TSP02110	TSP02095	16.5	7.5

Design Features

* Steel Screw Plug

* Steel Elements

* NEMA 1 Terminal Housing

Nominal Pipe Size	Immersed Length in mm		KW	W/Sq.In.	Part Number		Approximate Net Weight lbs kgs	
					No Thermostat 120V-1Ph	With 60-250°F Thermostat 120V-1Ph		
1" NPT	12 ¹ / ₁₆	319	0.475	21	TSP02216	TSP02204	6.6	3.0
1-1/4" NPT	12 ³ / ₄	324	1.0	23	TSP02217	TSP02205	6.7	3.0
	18 ¹ / ₂	470	1.5	23	TSP02220	TSP02208	8.2	3.7

Nominal Pipe Size	Immersed Length in mm		KW	W/Sq.In.	Part Number				Approximate Net Weight lbs kgs	
					No Thermostat 240V-3Ph	With 60-250°F Thermostat 240V-3Ph	No Thermostat 480V-3Ph	With 60-250°F Thermostat 480V-3Ph		
2" NPT	18	457	3	21	TSP02221	TSP02209	—	—	8.4	3.8
	29	737	5	21	TSP02222	TSP02210	TSP02223	TSP02211	11.8	5.4
	40 ³ / ₈	1026	5	15	TSP03518	TSP03218	—	—	14.9	6.8
	43 ¹ / ₂	1105	7.5	21	—	—	TSP02010	TSP02213	15.3	7.0
	57 ¹ / ₂	1461	10	21	—	—	TSP02226	TSP02215	18.5	8.4

Stock Screw Plug Immersion Heaters With and Without Thermostats



Design Features

- * 304 Stainless Steel Screw Plug
- * 304 Stainless Steel Elements
- * NEMA 1 Terminal Housing

Nominal Pipe Size	Immersed Length in mm		KW	W/Sq.In.	Part Number		Approximate Net Weight lbs kgs	
					No Thermostat 120V-1Ph	With 60-250°F Thermostat 120V-1Ph		
1" NPT	6 ³ / ₈	162	0.5	46	TSP02241	TSP02011	3.1	1.4
	6 ³ / ₈	162	0.75	69	TSP02295	TSP02227	3.1	1.4
	6 ³ / ₈	162	1	92	TSP02242	TSP02228	3.1	1.4
	9 ¹ / ₄	235	1.5	90	TSP02244	TSP02230	3.5	1.6
1-1/4" NPT	6 ³ / ₈	156	1	90	TSP02243	TSP02229	3.2	1.5
	6 ³ / ₈	156	1.5	94	TSP02245	TSP02024	3.2	1.5

Design Features

- * 316 Stainless Steel Screw Plug
- * 316 Stainless Steel Elements
- * NEMA 1 Terminal Housing

Nominal Pipe Size	Immersed Length in mm		KW	W/Sq.In.	Part Number				Approximate Net Weight lbs kgs	
					No Thermostat 120V-1Ph	With 60-250°F Thermostat 120V-1Ph	No Thermostat 480V-3Ph	With 60-250°F Thermostat 480V-3Ph		
1" NPT	6 ³ / ₈	162	1	46	TSP02792	TSP02791	—	—	3.1	1.4
	9 ¹ / ₄	235	1.5	90	TSP02459	TSP02793	—	—	3.5	1.6
1-1/4" NPT	9 ¹ / ₄	235	2	90	TSP02795	TSP02794	—	—	4.0	1.8
2" NPT	12	305	4.5	54	—	—	TSP03360	TSP03359	6.7	3.0
	19 ¹ / ₂	495	7.5	65	—	—	TSP03362	TSP03361	8.2	3.7
	28	711	10.5	61	—	—	TSP03364	TSP03363	11.8	5.4

Design Features

- * 304 Stainless Steel Screw Plug
- * Incoloy Elements
- * NEMA 1 Terminal Housing

Nominal Pipe Size	Immersed Length in mm		KW	W/Sq.In.	Part Number		Approximate Net Weight lbs kgs	
					No Thermostat 120V-1Ph	With 60-250°F Thermostat 120V-1Ph		
1" NPT	12 ¹ / ₁₆	319	0.475	21	TSP02264	TSP02254	4	1.8
	28 ⁷ / ₁₆	722	1.1	21	TSP02265	TSP02255	7	3.2
	34 ⁷ / ₈	886	1.325	21	TSP02266	TSP02256	8	3.6
1-1/4" NPT	11	279	1.5	37	TSP03520	TSP03519	6.5	2.9
	15 ¹ / ₂	394	3	52	TSP03522	TSP03521	7.5	3.4

Nominal Pipe Size	Immersed Length in mm		KW	W/Sq.In.	Part Number				Approximate Net Weight lbs kgs	
					No Thermostat 240V-3Ph	With 60-250°F Thermostat 240V-3Ph	No Thermostat 480V-3Ph	With 60-250°F Thermostat 480V-3Ph		
2" NPT	13	330	5	50	TSP03525	TSP03524	TSP03533	TSP03532	8	3.6
	22	559	5	28	TSP03526	TSP02258	TSP03536	TSP02012	11	5.0
	20	508	7.5	46	TSP03528	TSP03527	TSP03535	TSP03534	10	4.5
	25	635	10	48	TSP03531	TSP03530	TSP03538	TSP03537	12	5.4
	43	1092	10	27	—	—	TSP03539	TSP02260	15	6.8
2-1/2" NPT	32 ¹ / ₄	819	12	44	—	—	TSP02298	TSP02261	12	5.4
	39 ⁷ / ₈	1013	15	44	—	—	TSP02299	TSP02262	14	6.4
	47 ³ / ₈	1203	18	44	—	—	TSP02300	TSP02263	16.5	7.5

Standard (Non-Stock) Self-Contained Immersion Heaters

Design Features

This immersion heater is specifically designed for commercial dishwashers and sterilizing equipment. However, due to the unique construction characteristics of these heaters, they are readily adaptable for use in other water heating applications. The heating elements are prewired to a Definite Purpose contactor, thermostat and high limit cutout. The thermowell is located at the top of the element bundle for fast shut-off response, preventing overheating due to low water level conditions.

- * 2" NPT Brass screw plug
- * Three Incoloy® 800 tubular elements
- * Thermostat — 60°F (15°C) to 250°F (120°C) range
- * 350°F (177°C) Over-temperature cutout with manual reset
- * Internal Definite Purpose contactor with 120V holding coil
- * NEMA 4 moisture resistant housing
- * Silicone resin element seal standard



Optional Mounting Kit (Part Number KTT00281) — Clamping nut, flat washer and gasket for mounting heater in thin wall tanks with a 2-3/8" (60 mm) diameter opening.



Immersed Length		KW	Part Number					Approximate Net Weight	
in	mm		208-1Ph	208-3Ph	240V-1Ph	240V-3Ph	480V-3Ph	lbs	kgs
13 1/4	333	5	TSP01550	TSP01551	TSP01552	TSP01553	TSP01554	3	1
18 3/4	476	7.5	TSP01555	TSP01556	TSP01557	TSP01558	TSP01559	3	1
23 3/4	606	10	TSP01560	TSP01561	TSP01562	TSP01563	TSP01564	4	2
30 3/4	768	12	—	TSP01566	—	TSP01568	TSP01569	5	2
32 1/2	826	15	—	TSP01570	—	TSP01571	TSP01572	6	3
35 3/4	908	16	—	TSP01573	—	TSP01574	TSP01575	7	3
45 3/4	1162	20	—	—	—	TSP01576	TSP01577	9	4

Standard lead time is 2 to 3 weeks.

Standard (Non-Stock) General Purpose Hot Water Tank Heaters

Design Features

- * 1"-1 1/2" NPSM Brass Plug with O-Ring gasket (NPT optional)
- * Incoloy® 800 Tubular Element
- * 10-32 plated screw terminals
- * 90°C epoxy seal standard
- * Optional ceramic terminal block for high temperature applications

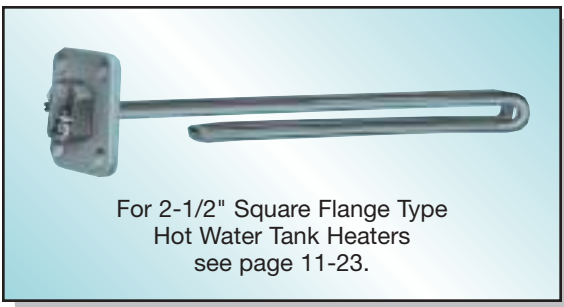
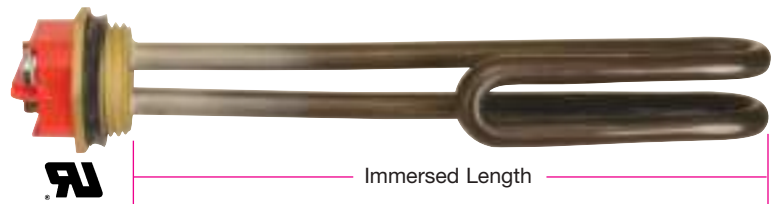
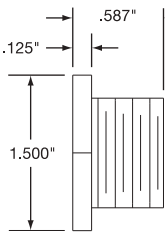

Immersed Length		KW	Voltage	Plug Material	Element Configuration	Part Number
in	mm					
8 9/16	218	3.0	208	Steel	Foldback	TSP01200
8 9/16	218	3.0	230	Steel	Foldback	TSP01198
8 9/16	218	3.0	460	Steel	Foldback	TSP01161
10 13/16	275	2.0	230	Steel	No Foldback	TSP01259
10 3/8	264	2.0	460	Steel	No Foldback	TSP01195
12 13/16	325	4.0	230	Steel	Foldback	TSP01324
7 7/8	187	1.5	240	Brass	Foldback	TSP01286
15 7/8	403	4.5	240	Brass	Foldback	TSP01148

Standard lead time is stock to 3 weeks.