

Hot Air Tools

General Description

Hot Air Tools are multi-purpose electric heaters with a built-in thermocouple for precise temperature control. The compact size makes this product perfect for single phase OEM applications. Its 304 stainless steel body construction is slotted for flared accessories and is made to withstand pressures up to 60 psi (4 bar) and temperatures up to 1400°F (760°C)

Closed-Loop Connection Diagram

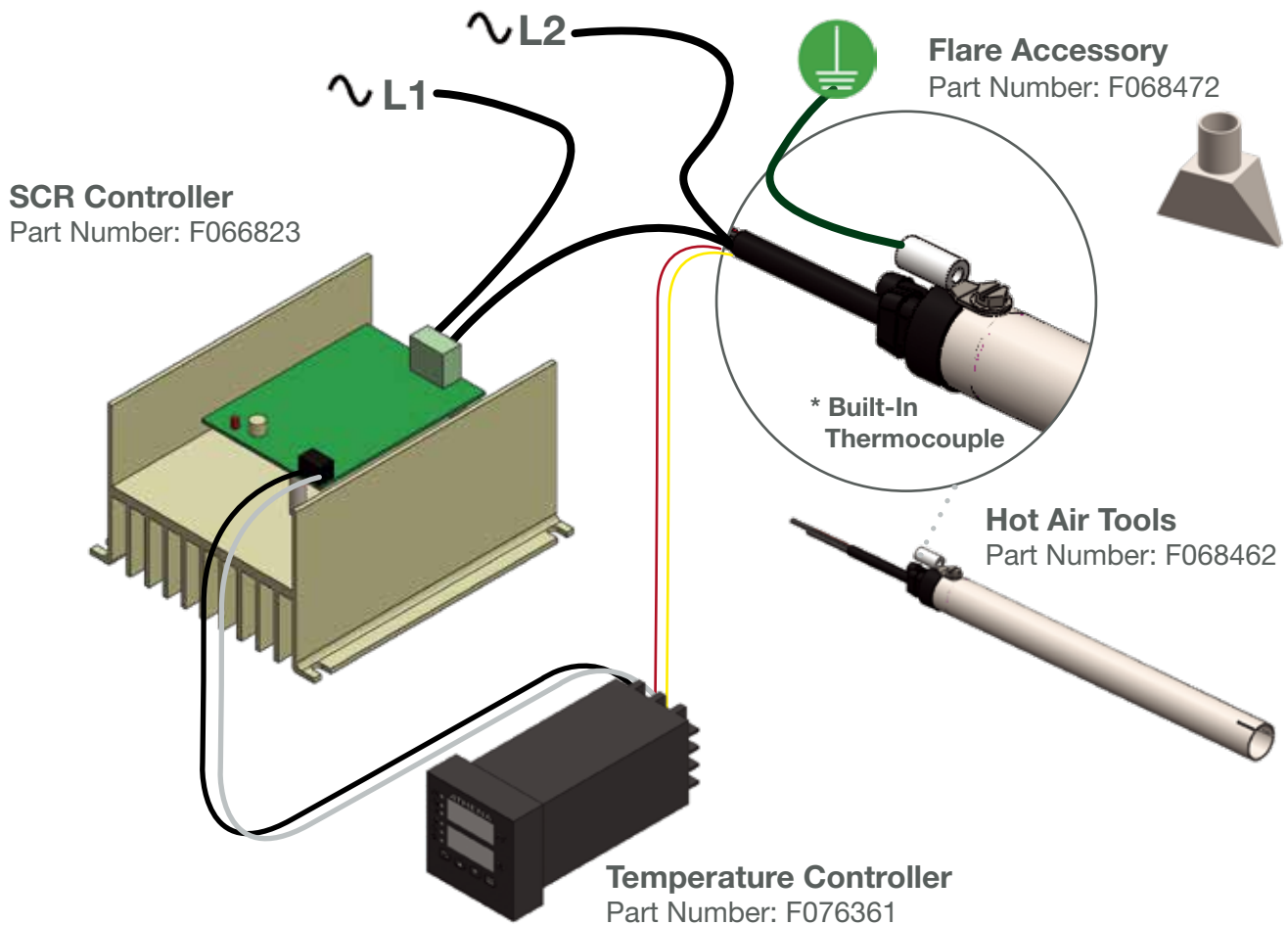

Minimizing Hot Air Tools Element Failures



1. Always ensure air is flowing before powering the heating element
2. Slowly regulate the ramp up time using the potentiometer to control the AC voltage
3. Use a temperature controller with 100ms cycle time

Dimensions / Installation Reference

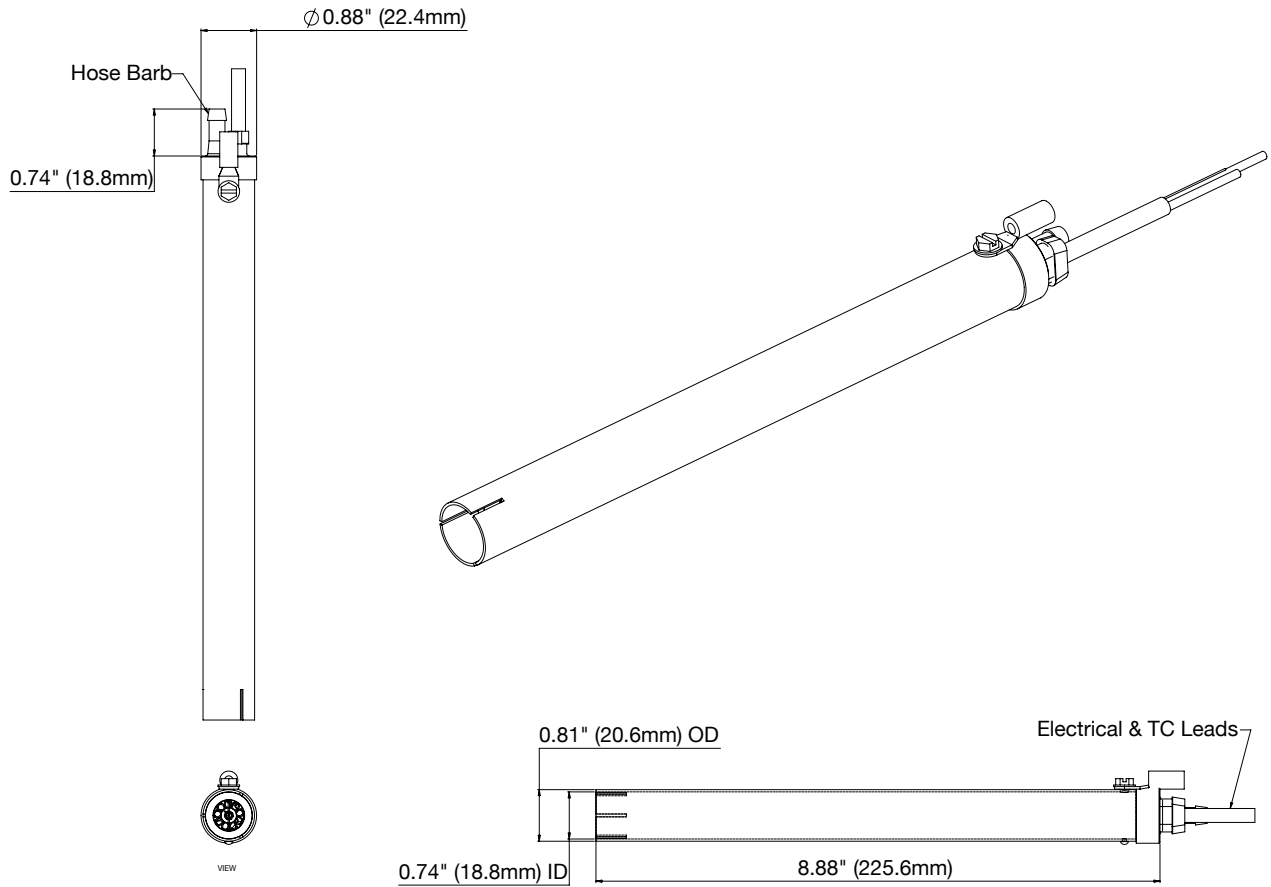

Hot Air Tools

Part Number	Max. Watt	Max. Volts	Max. Amps
F068462	1.5kW	120V	12.5A
F068463	2.0kW	240V	8.3A
F068464	3.5kW	240V	14.6A

Hot Air Tools Accessories

Part Number	Description
F068472	Flare Attachment Accessory
F066823	Closed-Loop SCR Power Controller
F076361	Digital Temperature Controller

Hot Air Tools Performance Curves

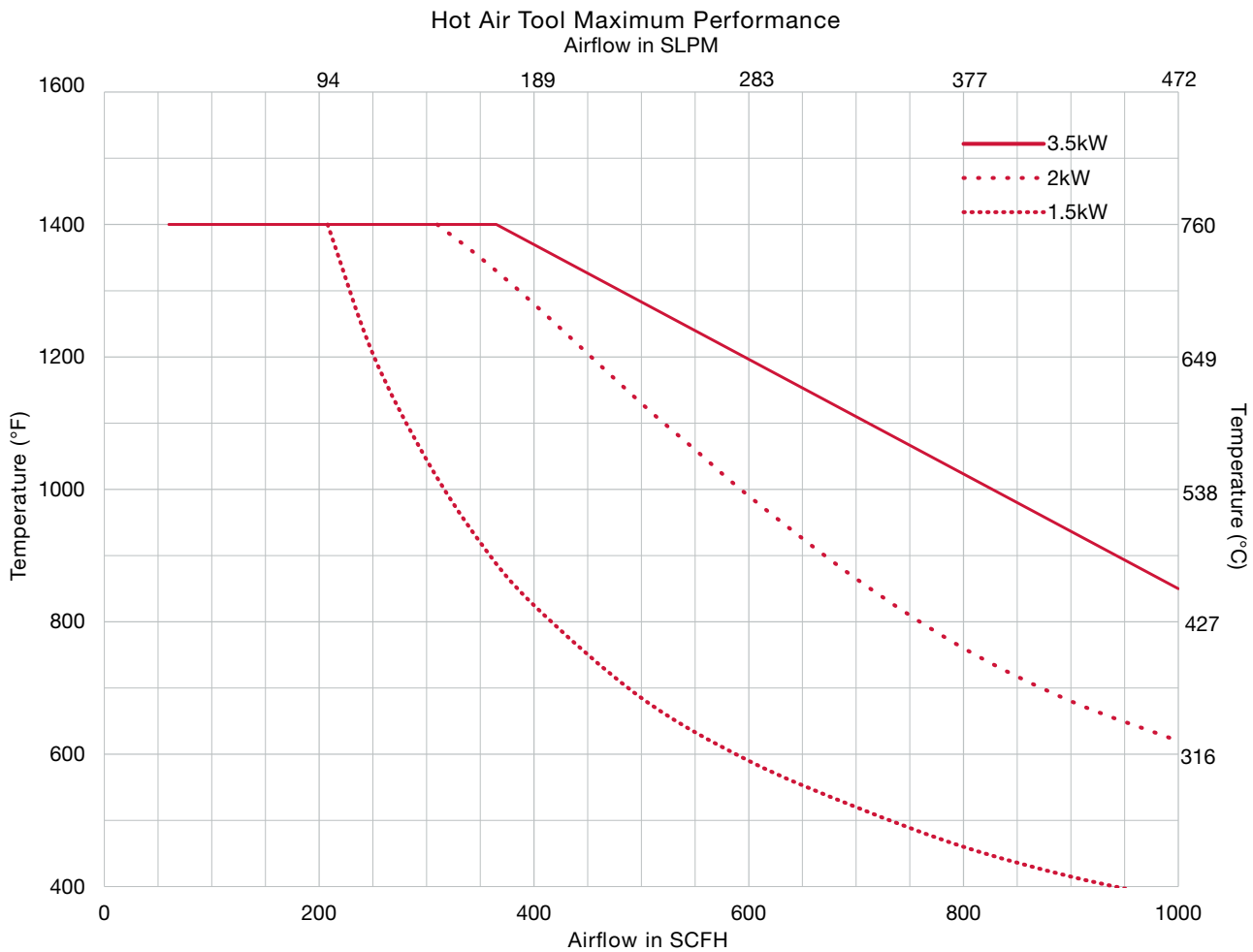

Notes:

- Temperatures are measured by internal 'K' T/C sensors. Use of other sensor types and / or locations can result in heater damage.
- Minimum airflow for accurate control is 60 SCFH
- Maximum air temperature is 1400°F (760°C) with supplied "K" T/C. Operating above this curve will void the product warranty.

